

1. ALL RESISTANCE VALUES ARE IN OHMS, 0.1 WATT +/- 5%.
2. ALL CAPACITANCE VALUES ARE IN MICROFARADS.
3. ALL CRYSTALS & OSCILLATOR VALUES ARE IN HERTZ.

REV	ECN	DESCRIPTION OF REVISION	CK APPD	DATE
8	0006532879	ENGINEERING RELEASED		2016-07-06

D11 MLB - PVT

LAST_MODIFICATION=Wed Jul 6 08:55:26 2016

PAGE	<CSA>	CONTENTS	SYNC	DATE	PAGE	<CSA>	CONTENTS	SYNC	DATE
1	1	TABLE OF CONTENTS	<SYNC_MASTER1>	<SYNC_DATE1>	46	46	LARGE FORM FACTOR SPECIFIC		<SYNC_DATE46>
2	2	SYSTEM:BOM TABLES	<SYNC_MASTER2>	<SYNC_DATE2>	47	47	I2C MAP: AP, TOUCH, HOMER, I2C5		
3	3	SYSTEM:EEEE CALLOUTS	<SYNC_MASTER3>		48	48	I2C MAP AOP	<SYNC_MASTER48>	<SYNC_DATE48>
4	4	SYSTEM:MECHANICAL COMPONENTS	<SYNC_MASTER4>	<SYNC_DATE4>	49	49	I2C TABLE	<SYNC_MASTER49>	<SYNC_DATE49>
5	5	SYSTEM: BOARDID	<SYNC_MASTER5>	<SYNC_DATE5>	50	50	spare	<SYNC_MASTER50>	<SYNC_DATE50>
6	6	spare			51	51	spare	<SYNC_MASTER51>	<SYNC_DATE51>
7	7	SOC:JTAG,USB,XTAL			52	52	MLB UNIQUE	<SYNC_MASTER52>	<SYNC_DATE52>
8	8	SOC:PCIE			53	53	CELL,WIFI,NFC	<SYNC_MASTER53>	<SYNC_DATE53>
9	9	SOC:MIPI AND ISP			54	54	pagel		
10	10	SOC:LPDP			55	55	NFC		
11	11	SOC:SERIAL			56	56	pagel		
12	12	SOC:GPIO & UART			57	57	METROCIRC [2]		
13	13	SOC:AOP			58	58	UAT MATCH AND TUNER [3]		
14	14	SOC:POWER (1/3)			59	59	WIFI_MLB SCHEMATIC		
15	15	SOC:POWER (2/3)			60	60	PERENNIAL		
16	16	SOC:POWER (3/3)			61	61	WIFI FRONT-END [77]		
17	17	NAND			62	62	pagel		
18	18	SYSTEM POWER:PMU (1/3)			63	63	BOM_OMIT_TABLE		
19	19	SYSTEM POWER:PMU (2/3)			64	64	PMU: CONTROL AND CLOCKS		
20	20	SYSTEM POWER:PMU (3/3)			65	65	PMU: SWITCHERS AND LDOS		
21	21	SYSTEM POWER:CHARGER			66	66	BASEBAND: POWER2		
22	22	SYSTEM POWER:BATTERY CONN			67	67	BASEBAND: CONTROL		
23	23	SYSTEM POWER:BOOST			68	68	BASEBAND GPIOs		
24	24	SENSORS			69	69	TRANSCIEVER0/1: POWER		
25	25	B2B FILTERS: UTAH			70	70	TRANSCIEVER0/1: TX PORTS		
26	26	CAMERA:STROBE DRIVER			71	71	TRANSCIEVER0/1: PRX PORTS	<SYNC_MASTER71>	<SYNC_DATE71>
27	27	Accessory: Buck Circuit		<SYNC_DATE27>	72	72	RECEIVE MATCHING	<SYNC_MASTER72>	<SYNC_DATE72>
28	28	TRINITY:FF SPECIFIC			73	73	LOWER ANTENNA & COUPLERS	<SYNC_MASTER73>	<SYNC_DATE73>
29	29	B2B:FOREHEAD			74	74	DIVERSITY RECEIVE ASM'S	<SYNC_MASTER74>	<SYNC_DATE74>
30	30	B2B:NEVADA		<SYNC_DATE30>	75	75	DIVERSITY RECEIVE LNA'S	d	
31	31	AUDIO:CALTRA CODEC (1/2)			76	76	UPPER ANTENNA FEEDS		
32	32	AUDIO:CALTRA CODEC (2/2)			77	77	PMU: ET MODULATOR		
33	33	AUDIO:SPEAKER AMP 2			78	<CSA_PAGE78>	TEST POINTS & BOOT CONFIG	<SYNC_MASTER78>	<SYNC_DATE78>
34	34	AUDIO:SPEAKER AMP 1			79	<CSA_PAGE79>	TDD TRANSMIT	<SYNC_MASTER79>	<SYNC_DATE79>
35	35	ARC:DRIVER			80	<CSA_PAGE80>	FDD TRANSMIT	<SYNC_MASTER80>	<SYNC_DATE80>
36	36	ARC:MAGGIE			81	<CSA_PAGE81>	ICEFALL, SIM, DEBUG_CONN	<SYNC_MASTER81>	<SYNC_DATE81>
37	37	DISPLAY & MESA:POWER				<CSA_PAGE82>		<SYNC_MASTER82>	<SYNC_DATE82>
38	38	B2B:ORB & MESA				<CSA_PAGE83>		<SYNC_MASTER83>	<SYNC_DATE83>
39	39	B2B FILTERS: DISPLAY & TOUCH				<CSA_PAGE84>		<SYNC_MASTER84>	<SYNC_DATE84>
40	40	TRISTAR 2				<CSA_PAGE85>		<SYNC_MASTER85>	<SYNC_DATE85>
41	41	B2B:DOCK FLEX				<CSA_PAGE86>		<SYNC_MASTER86>	<SYNC_DATE86>
42	42	spare				<CSA_PAGE87>		<SYNC_MASTER87>	<SYNC_DATE87>
43	43	spare				<CSA_PAGE88>		<SYNC_MASTER88>	<SYNC_DATE88>
44	44	B2B FILTERS: RIGHT BUTTON FLEX				<CSA_PAGE89>		<SYNC_MASTER89>	<SYNC_DATE89>
45	45	B2B FF SPECIFIC				<CSA_PAGE90>		<SYNC_MASTER90>	<SYNC_DATE90>

TABLE OF CONTENTS

VIETMOBILE.VN

Schematic & PCB Callouts

PART#	QTY	DESCRIPTION	REFERENCE DESIGNATOR(S)	CRITICAL	BOM OPTION
051-00482	1	SCH,MLB,D11-12	SCH	CRITICAL	?
820-00229	1	PCBF,MLB,D11-12	PCB	CRITICAL	?

SCH 051-00482
BRD 820-00229
MCO 056-01585

System Block Diagram:

<rdar://problem/16684269>

TABLE OF CONTENTS		SYNC_MASTER=david-copy	SYNC_DATE=03/01/2016
DRAWING TITLE			
SCH,MLB,D11			
Apple Inc.	DRAWING NUMBER	051-00482	SIZE D
	REVISION	8.0.0	
NOTICE OF PROPRIETARY PROPERTY:			
THE INFORMATION CONTAINED HEREIN IS THE PROPRIETARY PROPERTY OF APPLE INC. THE POSSESSOR AGREES TO THE FOLLOWING:			
I TO MAINTAIN THIS DOCUMENT IN CONFIDENCE			
II NOT TO REPRODUCE OR COPY IT			
III NOT TO REVEAL OR PUBLISH IT IN WHOLE OR PART			
IV ALL RIGHTS RESERVED			
BRANCH	PAGE	SHEET	
	1 OF 53	1 OF 81	

8

7

6

5

4

3

2

1

NAND BOM Options

PART#	QTY	DESCRIPTION	REFERENCE DESIGNATOR(S)	CRITICAL	BOM OPTION
335S00169	1	NAND, H, 32GB, 16nm, MLC	U1701	CRITICAL	NAND_32G
335S00182	1	NAND, H, 128GB, 16nm, TLC	U1701	CRITICAL	NAND_128G
335S00183	1	NAND, T, 256GB, 3Dv3, TLC	U1701	CRITICAL	NAND_256G
138S00867	5	CAP, XSR, 150P, 20V, 4.7V, 0.45MM, 0805, 0402	C1748, C1713, C1716, C1721, C1733	CRITICAL	NAND_32G
138S00003	5	CAP, XSR, 150P, 20V, 4.7V, 0.45MM, 0805, 0402	C1748, C1713, C1716, C1721, C1733	CRITICAL	NAND_128G
138S00003	5	CAP, XSR, 150P, 20V, 4.7V, 0.45MM, 0805, 0402	C1748, C1713, C1716, C1721, C1733	CRITICAL	NAND_256G

PART NUMBER	ALTERNATE FOR PART NUMBER	BOM OPTION	REF DES	COMMENTS:
335S00201	335S00169	ALTERNATE	U1701	T, 15nm, MLC, 32GB
335S00209	335S00169	ALTERNATE	U1701	S, 16nm, MLC, 32GB
335S00195	335S00182	ALTERNATE	U1701	SS, 11nm, TLC, 128GB
335S00180	335S00182	ALTERNATE	U1701	T, 15nm, TLC, 128GB
335S00179	335S00182	ALTERNATE	U1701	SD, 15nm, TLC, 128GB
335S00148	335S00183	ALTERNATE	U1701	SD, 3Dv2, TLC, 256GB
335S00190	335S00183	ALTERNATE	U1701	SS, 3Dv3, TLC, 256GB

#22686038: See Radar

Active Diode Alternate

PART NUMBER	ALTERNATE FOR PART NUMBER	BOM OPTION	REF DES	COMMENTS:
376S00106	376S00047	ALTERNATE	Q2101	DIODES INC. ACT DIODE

DDR PLL Alternate

PART NUMBER	ALTERNATE FOR PART NUMBER	BOM OPTION	REF DES	COMMENTS:
155S00095	155S00068	ALTERNATE	FL1501	PNR: 80, 100MHZ, 2V, 0.5MM, 2008, 0105

Power Inductor Alternates

PART NUMBER	ALTERNATE FOR PART NUMBER	BOM OPTION	REF DES	COMMENTS:
152S00118	152S00075	ALTERNATE	ALL	330, 400, 0805, 1.3 OHM, 2.5A, 0.541 OHM, 2014
152S00077	152S00397	ALTERNATE	ALL	330, 400, 0805, 1.3 OHM, 2.5A, 0.541 OHM, 2014
152S00121	152S00081	ALTERNATE	ALL	330, 400, 0805, 1.47 OHM, 2.5A, 0.541 OHM, 2013
152S00123	152S1936	ALTERNATE	ALL	330, 400, 0805, 1.5 OHM, 2.5A, 0.541 OHM, 2013
152S00402	152S00366	ALTERNATE	ALL	330, 400, 0805, 1.6 OHM, 2.5A, 0.541 OHM, 2013
152S00297	152S1843	ALTERNATE	ALL	CITEC 2012 108
152S00365	152S00297	ALTERNATE	ALL	CITEC 2012 108
152S00398	152S00204	ALTERNATE	ALL	330, 400, 1.100H, 2V, 4.7V, 2.000MM, 2012
152S00120	152S00077	ALTERNATE	ALL	For Chestnut Inductor only
152S00117	152S00074	ALTERNATE	ALL	330, 400, 0805, 1.3 OHM, 2.5A, 0.541 OHM, 2014

updated 11/12

updated 11/12

reverted 11/13

For Chestnut inductor? so it doesn't interfere with PMU inductor Buck 7 alt

Except BUCKS LX (BUCKS LX is Taiyo only)

Acc Buck Alternates

PART NUMBER	ALTERNATE FOR PART NUMBER	BOM OPTION	REF DES	COMMENTS:
371S00087	371S00064	ALTERNATE	D2700	D5008, 8807REY, 3V, 200MA, 0201
152S00558	152S00557	ALTERNATE	L2700	IND, MLC, 0.47UH, 2.5A, 80MHz, 1608
376S00166	376S00164	ALTERNATE	Q2700, Q2701	999T, 1.2V, CSP4

Load Switch OMIT TABLE

PART#	QTY	DESCRIPTION	REFERENCE DESIGNATOR(S)	CRITICAL	BOM OPTION
353S01007	1	ONSEMI, IC, LOAD, SWITCH, MUCSP4	U2710, NPSCSW_RF	CRITICAL	

N&V 15uF Cap Alternates

PART NUMBER	ALTERNATE FOR PART NUMBER	BOM OPTION	REF DES	COMMENTS:
138S00005	138S00003	ALTERNATE	0201, 0204, 0205	CAP, 15UF, 16V, 3V, 0.45MM, 0402, 05
138S00005	138S00003	ALTERNATE	0207, 0240, 0241	CAP, 15UF, 16V, 3V, 0.45MM, 0402, 05
138S00005	138S00003	ALTERNATE	0209, 0240, 0241	CAP, 15UF, 16V, 3V, 0.45MM, 0402, 05
138S00005	138S00003	ALTERNATE	0209, 0241, 0242	CAP, 15UF, 16V, 3V, 0.45MM, 0402, 05
138S00005	138S00003	ALTERNATE	0241, 0240, 0241	CAP, 15UF, 16V, 3V, 0.45MM, 0402, 05
138S00005	138S00003	ALTERNATE	0241, 0240, 0241	CAP, 15UF, 16V, 3V, 0.45MM, 0402, 05
138S00005	138S00003	ALTERNATE	0241, 0240, 0241	CAP, 15UF, 16V, 3V, 0.45MM, 0402, 05
138S00005	138S00003	ALTERNATE	0241, 0240, 0241	CAP, 15UF, 16V, 3V, 0.45MM, 0402, 05
138S00005	138S00003	ALTERNATE	0241, 0240, 0241	CAP, 15UF, 16V, 3V, 0.45MM, 0402, 05
138S00005	138S00003	ALTERNATE	0241, 0240, 0241	CAP, 15UF, 16V, 3V, 0.45MM, 0402, 05
138S00048	138S00003	ALTERNATE	ALL	CAP, 15UF, 16V, 3V, 0.45MM, 0402, 02008A

MEM+KEY 150P

CPU

GPU + GPU_SCAN

Magnesium Alternates

PART NUMBER	ALTERNATE FOR PART NUMBER	BOM OPTION	REF DES	COMMENTS:
338S00173	338S00203	ALTERNATE	U2402	Target: Water (120 FLOW) Magnesium

UT LDO Alternates

PART NUMBER	ALTERNATE FOR PART NUMBER	BOM OPTION	REF DES	COMMENTS:
353S00889	353S00015	ALTERNATE	U2501	IC, 100 MA, 2.85V, CSP 0.45MM 05

Mamba LDO Alternates

PART NUMBER	ALTERNATE FOR PART NUMBER	BOM OPTION	REF DES	COMMENTS:
353S00932	353S00576	ALTERNATE	U3801	IC, 100 MA, 1.7V

I2C5 Alternate

PART NUMBER	ALTERNATE FOR PART NUMBER	BOM OPTION	REF DES	COMMENTS:
335S00234	335S00233	ALTERNATE	U1101	I2C5 ALTERNATE

Global Ferrite Alternates

PART NUMBER	ALTERNATE FOR PART NUMBER	BOM OPTION	REF DES	COMMENTS:
155S00067	155S00581	ALTERNATE	ALL	FERR, 2400MH, 0.380MM DCB, 0201
155S00581	155S00067	ALTERNATE	ALL	FERR, 2400MH, 0.380MM DCB, 0201
155S00012	155S00168	ALTERNATE	ALL	FLTR, 60 OHMS, 0405
155S00194	155S0610	ALTERNATE	ALL	FERR BD, 1500MH, TK
155S00200	155S0610	ALTERNATE	ALL	FERR BD, 1500MH, TY
152S00489	152S00456	ALTERNATE	ALL	FERR BD, 0.47UH, TY

Global Varistor Alternates

PART NUMBER	ALTERNATE FOR PART NUMBER	BOM OPTION	REF DES	COMMENTS:
377S0168	377S0140	ALTERNATE	ALL	VARIATOR, 4.0V, 100PF, 0105

VIETMOBILE.VN

PAGE TITLE			
SYSTEM: BOM TABLES			
 Apple Inc.		DRAWING NUMBER	SIZE
		051-00482	D
		REVISION	8.0.0
		BRANCH	
		PAGE	2 OF 53
		SHEET	2 OF 81
NOTICE OF PROPRIETARY PROPERTY: THE INFORMATION CONTAINED HEREIN IS THE PROPRIETARY PROPERTY OF APPLE INC. THE POSSESSOR AGREES TO THE FOLLOWING: I TO MAINTAIN THIS DOCUMENT IN CONFIDENCE II NOT TO REPRODUCE OR COPY IT III NOT TO REVEAL OR PUBLISH IT IN WHOLE OR PART IV ALL RIGHTS RESERVED			

8

7

6

5

4

3

2

1

D11 EEEE CALLOUTS

PART#	QTY	DESCRIPTION	REFERENCE DESIGNATOR(S)	CRITICAL	BOM OPTION
825-6838	1	EEEE CODE FOR 639-01812	EEEE_GY2T	CRITICAL	EEEE_D11_BEST_JP
825-6838	1	EEEE CODE FOR 639-01813	EEEE_GY2V	CRITICAL	EEEE_D11_SUPREME_JP
825-6838	1	EEEE CODE FOR 639-01814	EEEE_GY2W	CRITICAL	EEEE_D11_EXTREME_JP
825-6838	1	EEEE CODE FOR 639-02138	EEEE_H3RW	CRITICAL	EEEE_D11_BEST_ROW
825-6838	1	EEEE CODE FOR 639-02139	EEEE_H3RP	CRITICAL	EEEE_D11_SUPREME_ROW
825-6838	1	EEEE CODE FOR 639-02140	EEEE_H3RQ	CRITICAL	EEEE_D11_EXTREME_ROW
825-6838	1	EEEE CODE FOR 639-02460	EEEE_H8C1	CRITICAL	EEEE_D11_BEST_CH
825-6838	1	EEEE CODE FOR 639-02465	EEEE_H8CK	CRITICAL	EEEE_D11_SUPREME_CH
825-6838	1	EEEE CODE FOR 639-02462	EEEE_H8C3	CRITICAL	EEEE_D11_EXTREME_CH

CAYMAN DDR Alternates

PART#	QTY	DESCRIPTION	REFERENCE DESIGNATOR(S)	CRITICAL	BOM OPTION
339S00258					
339S00257		ALTERNATE	ALL		DDR-S, 3G, B1

CAYMAN OMIT TABLE

PART#	QTY	DESCRIPTION	REFERENCE DESIGNATOR(S)	CRITICAL	BOM OPTION
339S00257	1	CAYMAN, DDR-S, 3G, B1	U0700	CRITICAL	

2.2uF CAP Alts

PART NUMBER	ALTERNATE FOR PART NUMBER	BOM OPTION	REF DES	COMMENTS:
138S00049	138S00032	ALTERNATE	ALL	CAP_008_208_1_207_208_1C_208_1C_008A
138S0831	138S00032	ALTERNATE	ALL	CAP_008_208_1_207_208_1C_208_1C_008A

SIP Alternates

PART NUMBER	ALTERNATE FOR PART NUMBER	BOM OPTION	REF DES	COMMENTS:
339M00009	339M00003	ALTERNATE	ALL	TRINITY BLUE_STATS
339M00008	339M00002	ALTERNATE	ALL	NEO_STATS

SYNC_MASTER=david-copy		SYNC_DATE=03/01/2016	
PAGE TITLE			
SYSTEM:EEEE CALLOUTS			
 Apple Inc.	DRAWING NUMBER	051-00482	
	REVISION	8.0.0	
NOTICE OF PROPRIETARY PROPERTY: THE INFORMATION CONTAINED HEREIN IS THE PROPRIETARY PROPERTY OF APPLE INC. THE POSSESSOR AGREES TO THE FOLLOWING: I TO MAINTAIN THIS DOCUMENT IN CONFIDENCE II NOT TO REPRODUCE OR COPY IT III NOT TO REVEAL OR PUBLISH IT IN WHOLE OR PART IV ALL RIGHTS RESERVED	BRANCH		
	PAGE	3 OF 53	
	SHEET	3 OF 81	
	SIZE	D	

Current as of D11 MCO 056-01585 rev. 63

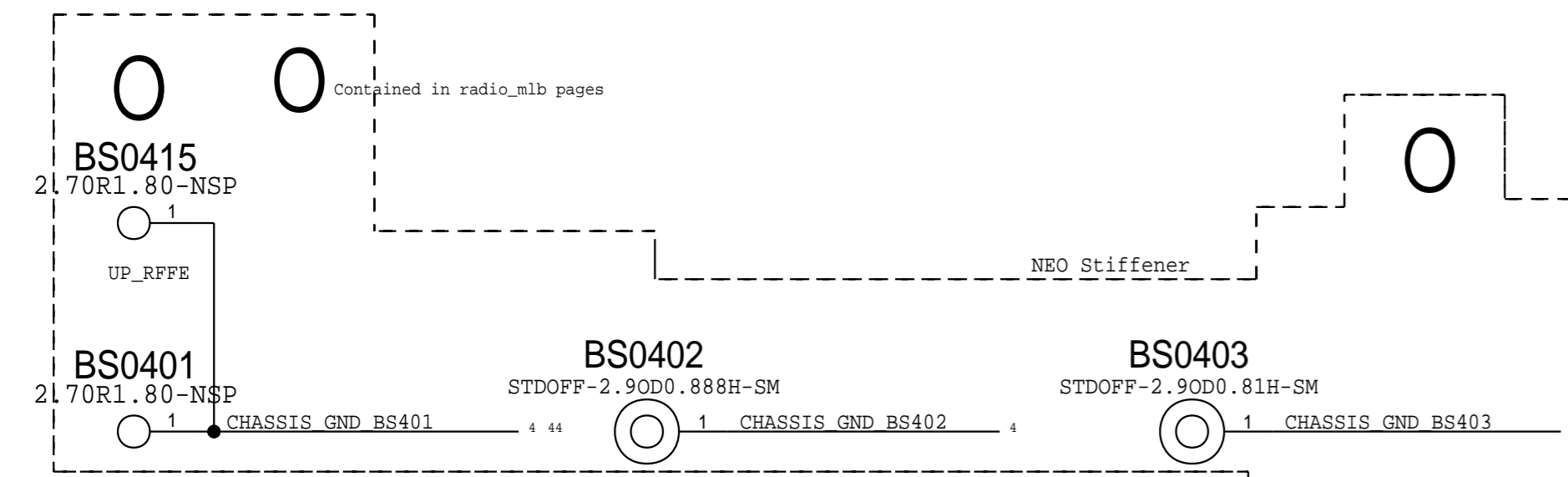

PTH per Rev63 for 1.8mm Drill

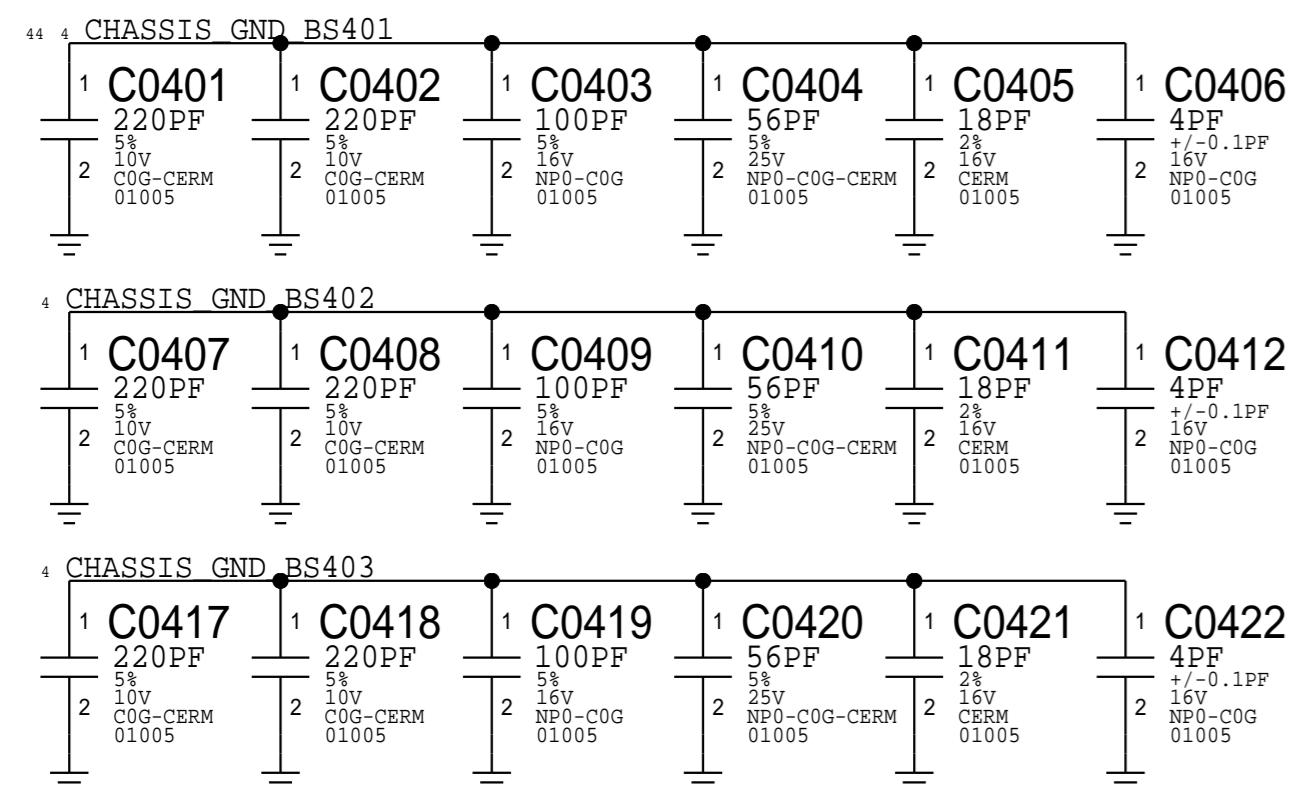

Front Shields

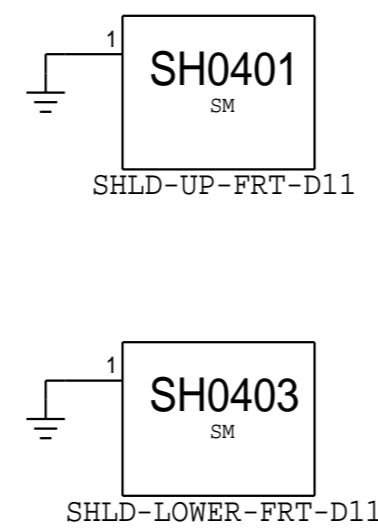

Back Shields

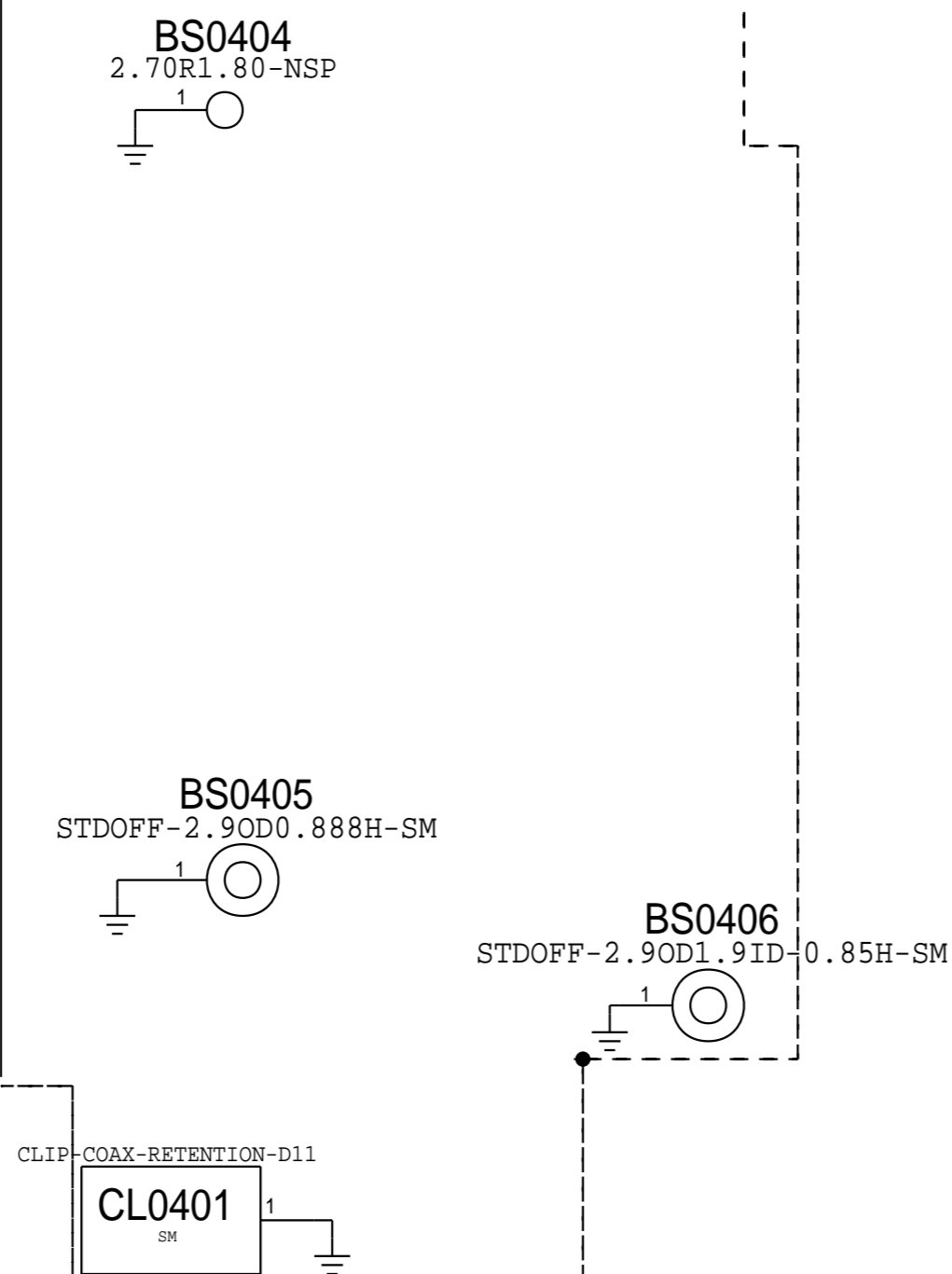
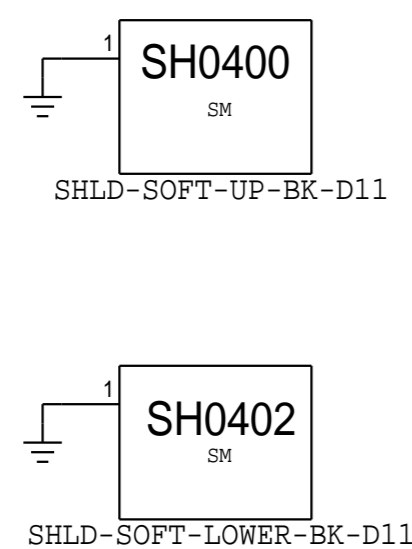

TESTPOINTS

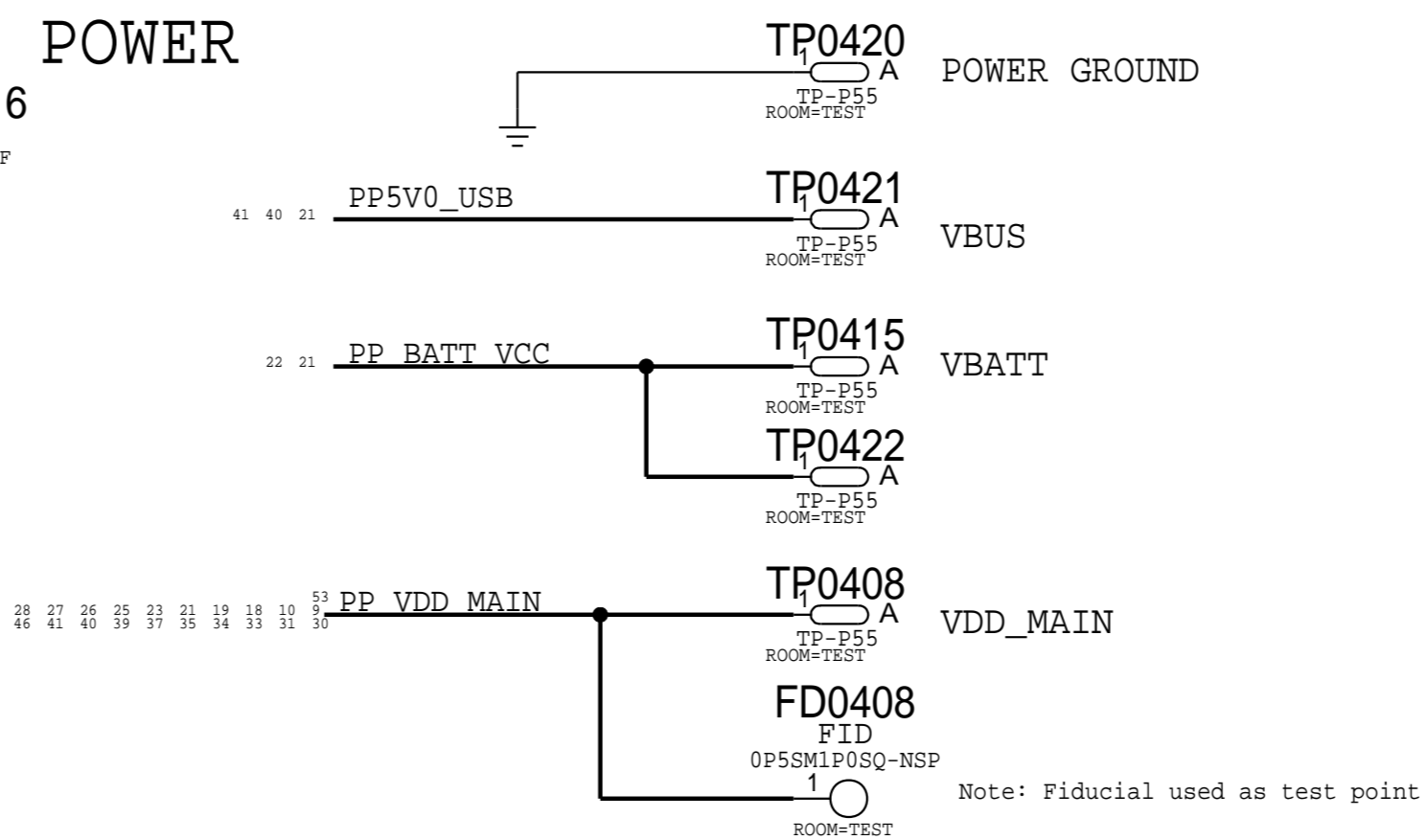

DFU

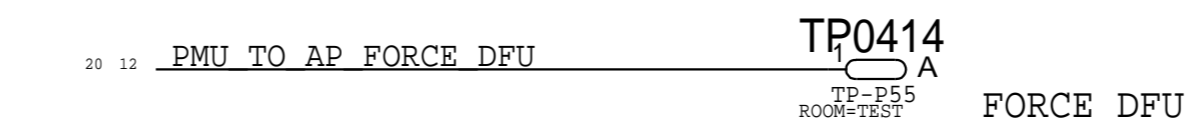

E75

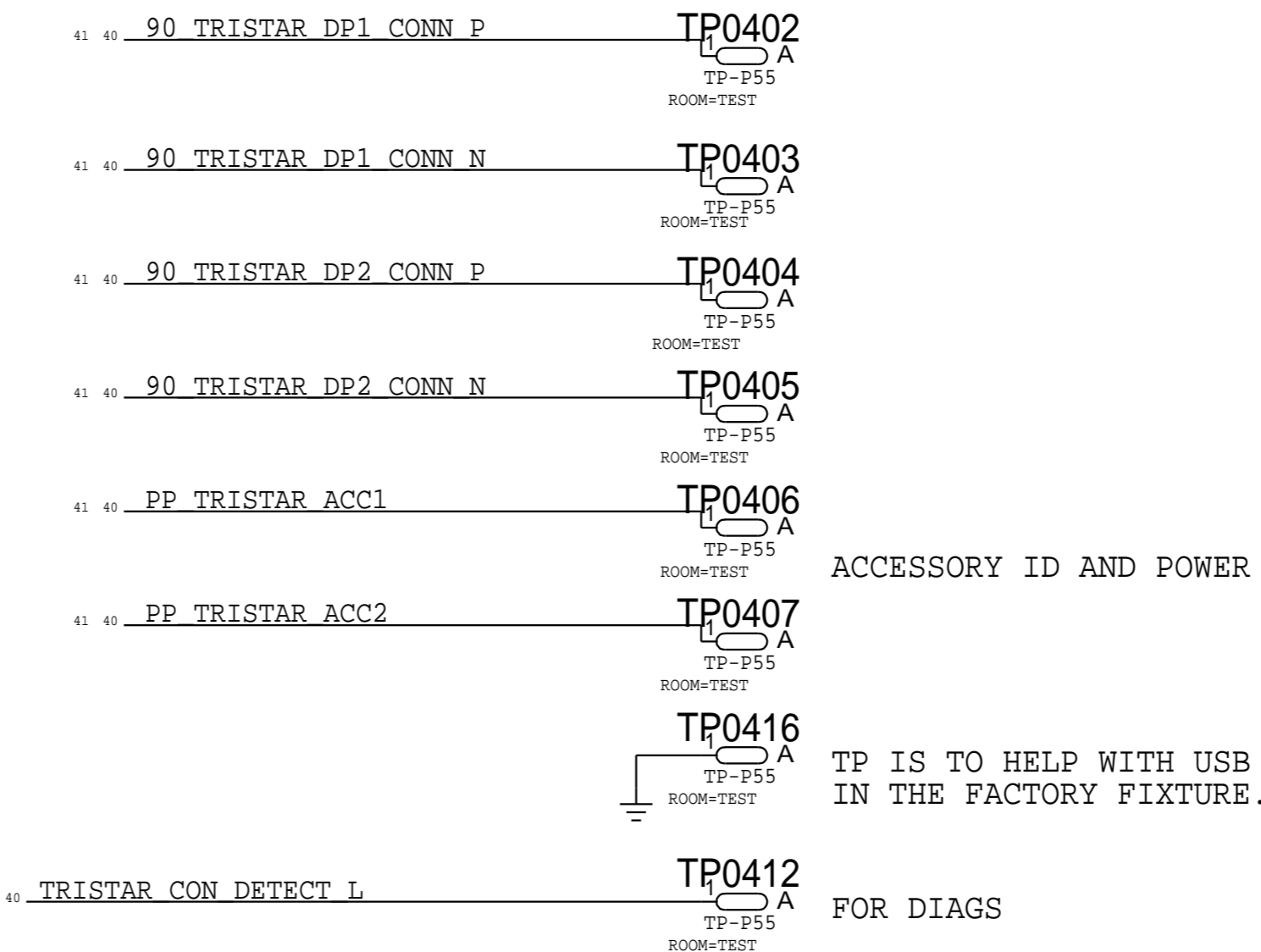

AMUX

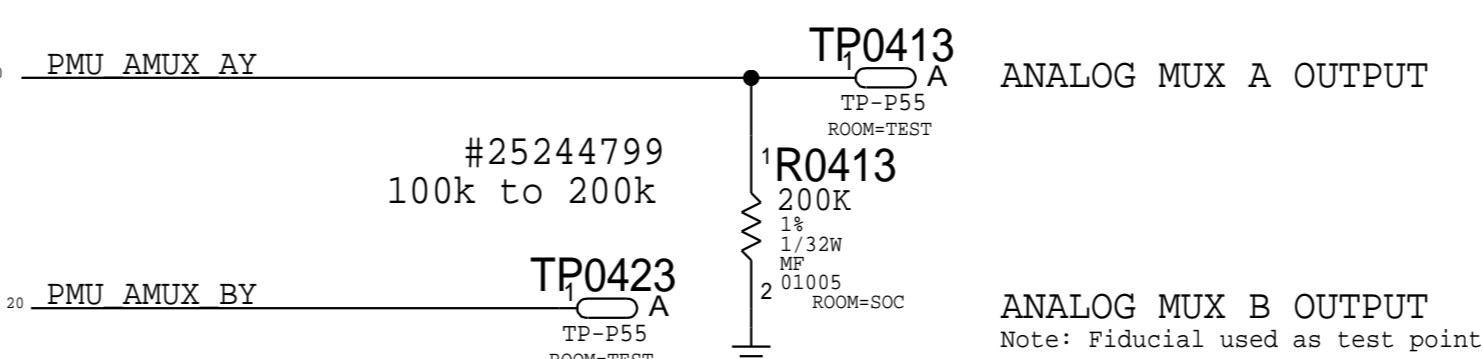

MOJAVE

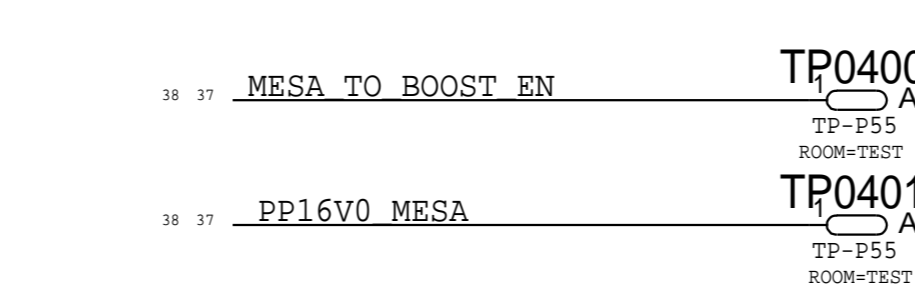

LCM

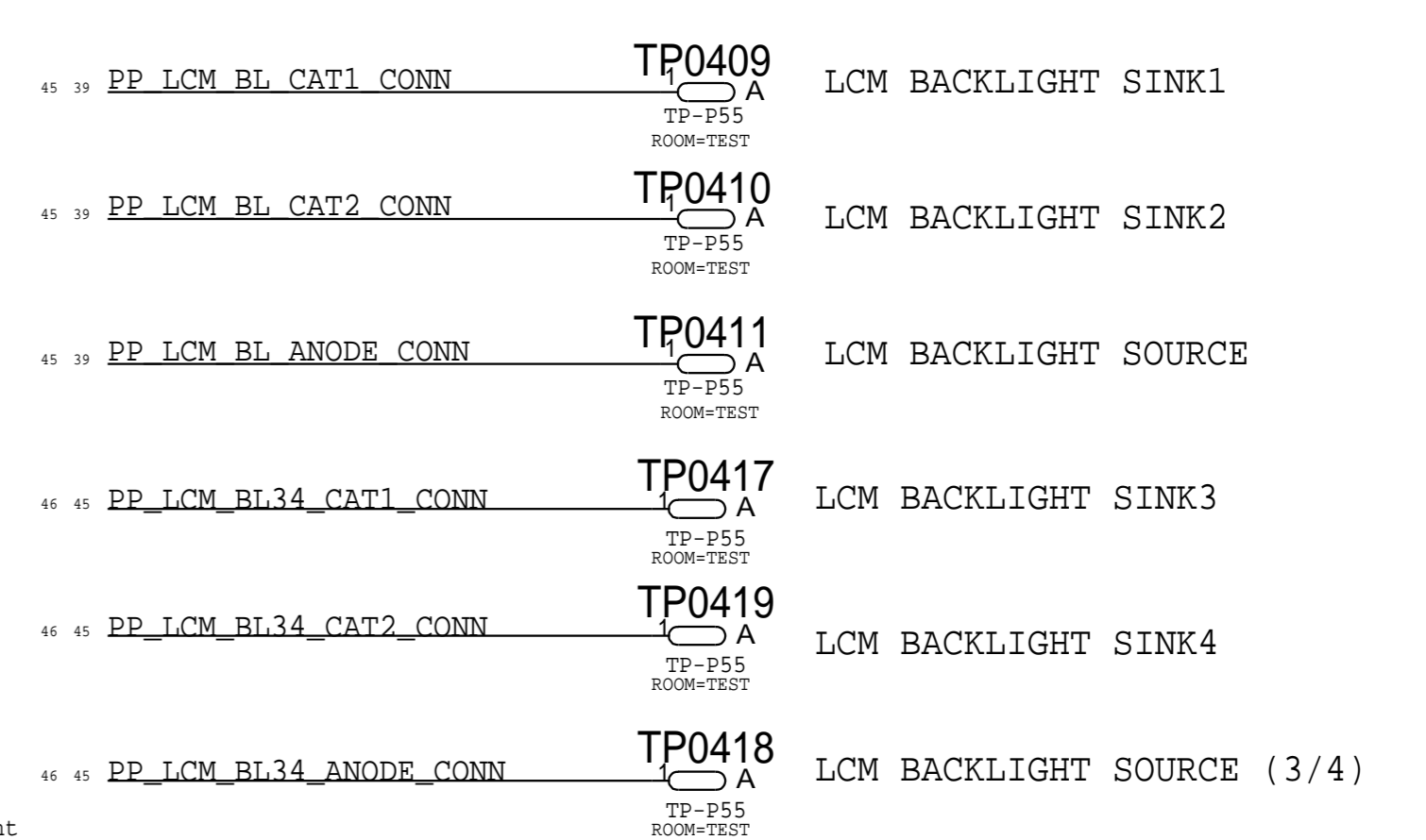

FIDUCIALS

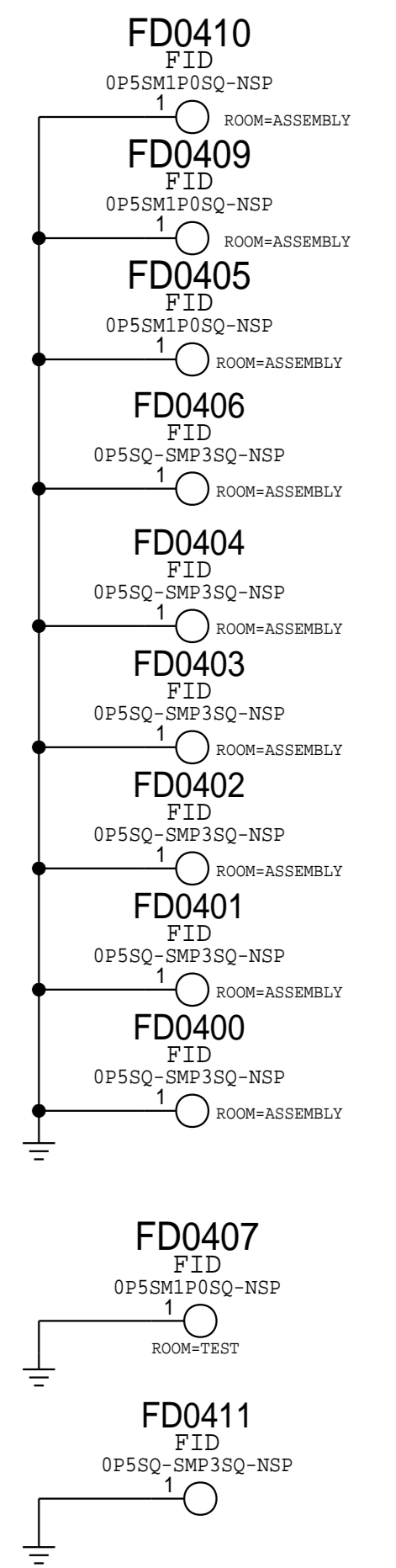

VIETMOBILE.VN

TOP SIDE

PAGE TITLE		
SYSTEM:MECHANICAL COMPONENTS		
Apple Inc.	DRAWING NUMBER	SIZE
	051-00482	D
REVISION		
8.0.0		
BRANCH		
PAGE		
4 OF 53		
SHEET		
4 OF 81		
NOTICE OF PROPRIETARY PROPERTY: THE INFORMATION CONTAINED HEREIN IS THE PROPRIETARY PROPERTY OF APPLE INC. THE POSSESSOR AGREES TO THE FOLLOWING: I TO MAINTAIN THIS DOCUMENT IN CONFIDENCE II NOT TO REPRODUCE OR COPY IT III NOT TO REVEAL OR PUBLISH IT IN WHOLE OR PART IV ALL RIGHTS RESERVED		

BOOTSTRAPPING: BOARD REV BOARD ID BOOT CONFIG

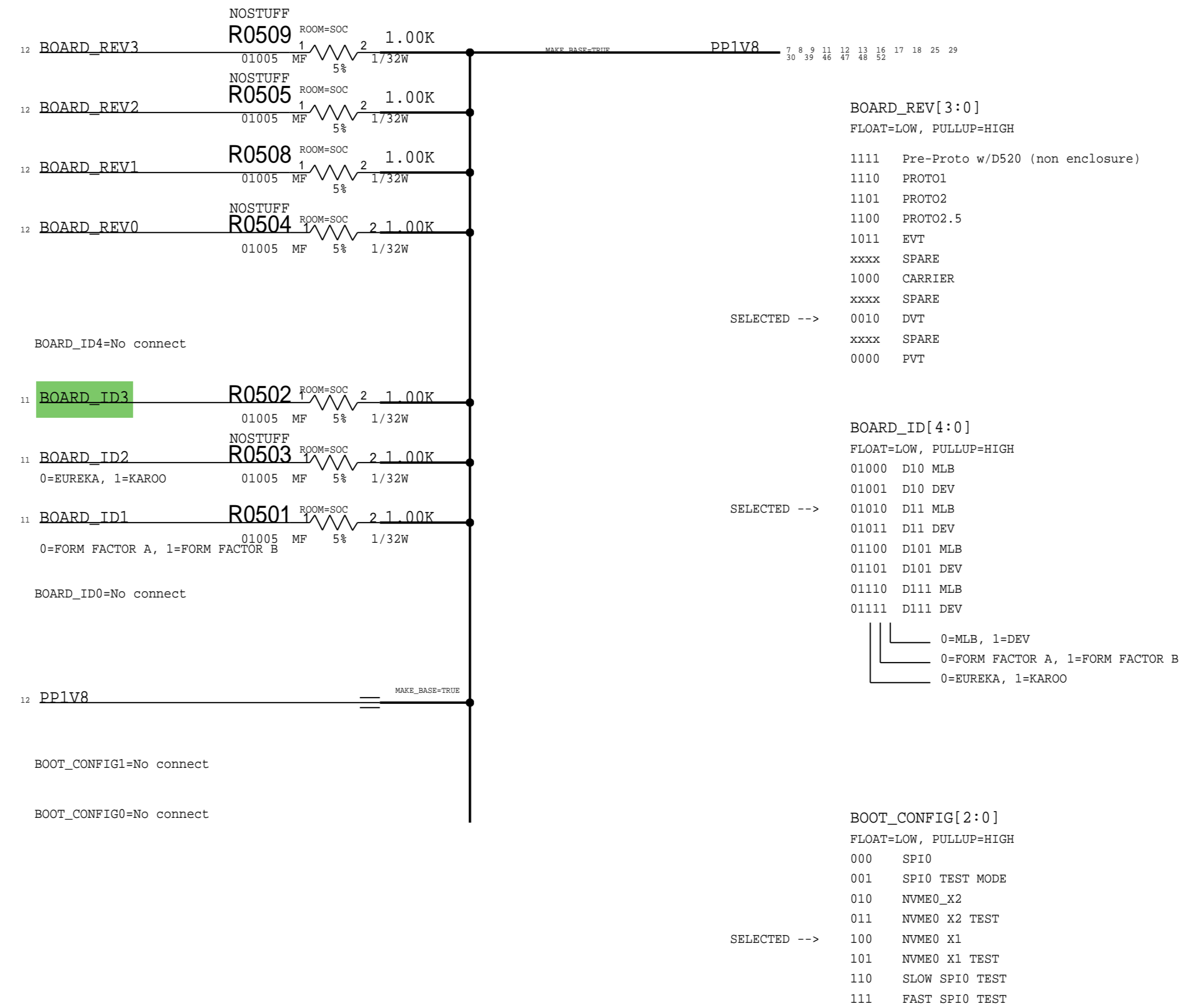

SYNC_MASTER=david-copy SYNC_DATE=03/01/2016
 PAGE TITLE SYSTEM: BOARDID

Apple Inc.	DRAWING NUMBER	SIZE
	051-00482	D
REVISION		8.0.0
BRANCH		
PAGE		5 OF 53
SHEET		5 OF 81

NOTICE OF PROPRIETARY PROPERTY:
 THE INFORMATION CONTAINED HEREIN IS THE PROPRIETARY PROPERTY OF APPLE INC.
 THE POSSESSOR AGREES TO THE FOLLOWING:
 I TO MAINTAIN THIS DOCUMENT IN CONFIDENCE
 II NOT TO REPRODUCE OR COPY IT
 III NOT TO REVEAL OR PUBLISH IT IN WHOLE OR PART
 IV ALL RIGHTS RESERVED

8

7

6

5

4

3

2

1

D

D

C

C

B

B

A

A

8

7

6

5

4

3

2

1

PAGE TITLE		spare	
 Apple Inc.	DRAWING NUMBER	051-00482	SIZE D
	REVISION	8.0.0	
NOTICE OF PROPRIETARY PROPERTY:		BRANCH	
THE INFORMATION CONTAINED HEREIN IS THE PROPRIETARY PROPERTY OF APPLE INC. THE POSSESSOR AGREES TO THE FOLLOWING: I TO MAINTAIN THIS DOCUMENT IN CONFIDENCE II NOT TO REPRODUCE OR COPY IT III NOT TO REVEAL OR PUBLISH IT IN WHOLE OR PART IV ALL RIGHTS RESERVED		PAGE 6 OF 53	
		SHEET 6 OF 81	

SOC - USB, JTAG, XTAL

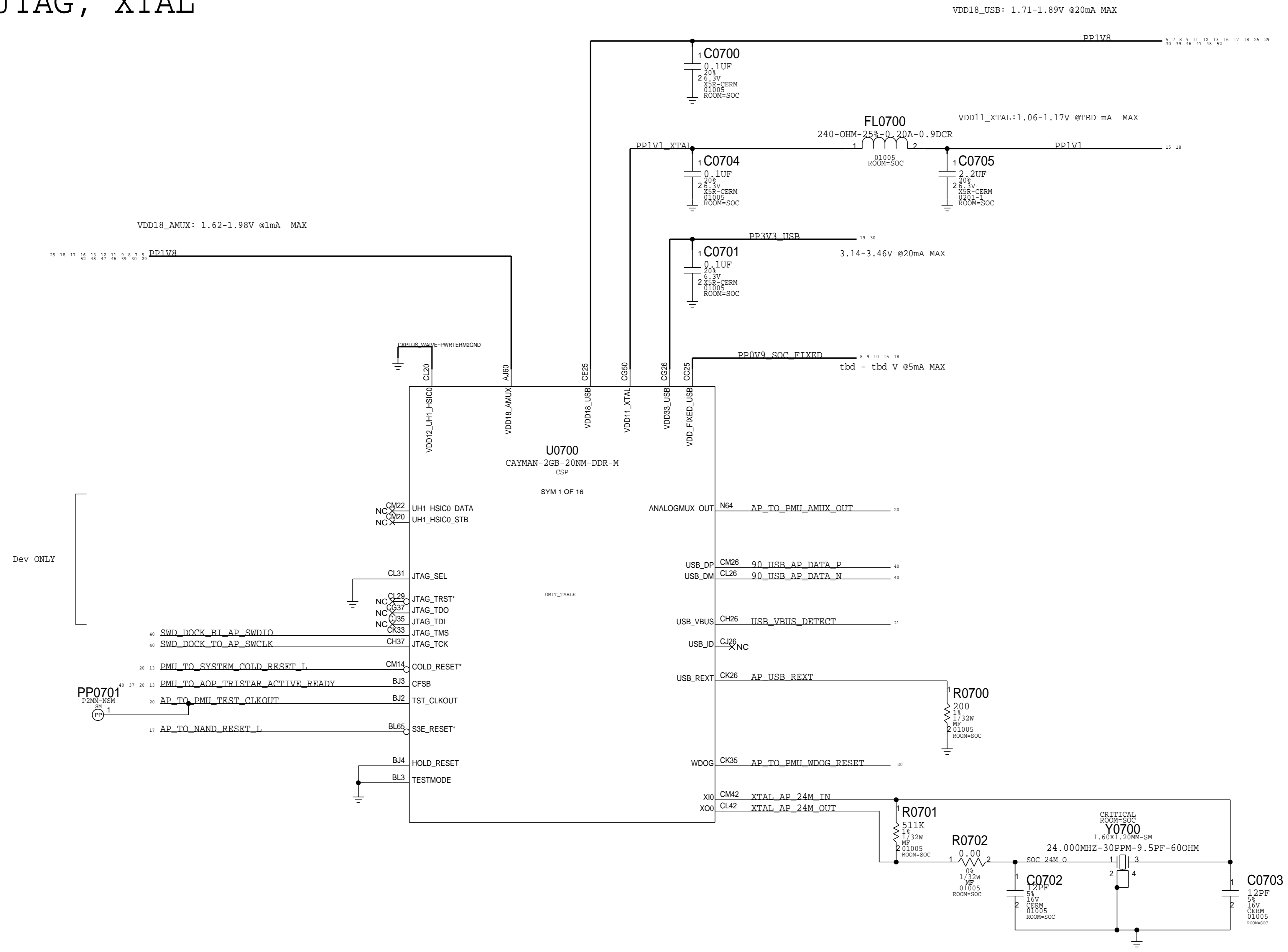

PAGE TITLE		
SOC: JTAG, USB, XTAL		
	DRAWING NUMBER	051-00482
	REVISION	8.0.0
NOTICE OF PROPRIETARY PROPERTY:		
THE INFORMATION CONTAINED HEREIN IS THE PROPRIETARY PROPERTY OF APPLE INC. THE POSSESSOR AGREES TO THE FOLLOWING: I TO MAINTAIN THIS DOCUMENT IN CONFIDENCE II NOT TO REPRODUCE OR COPY IT III NOT TO REVEAL OR PUBLISH IT IN WHOLE OR PART IV ALL RIGHTS RESERVED		
BRANCH		
PAGE	7 OF 53	
SHEET	7 OF 81	

SOC - PCIE INTERFACES

D

C

B

A

D

C

B

A

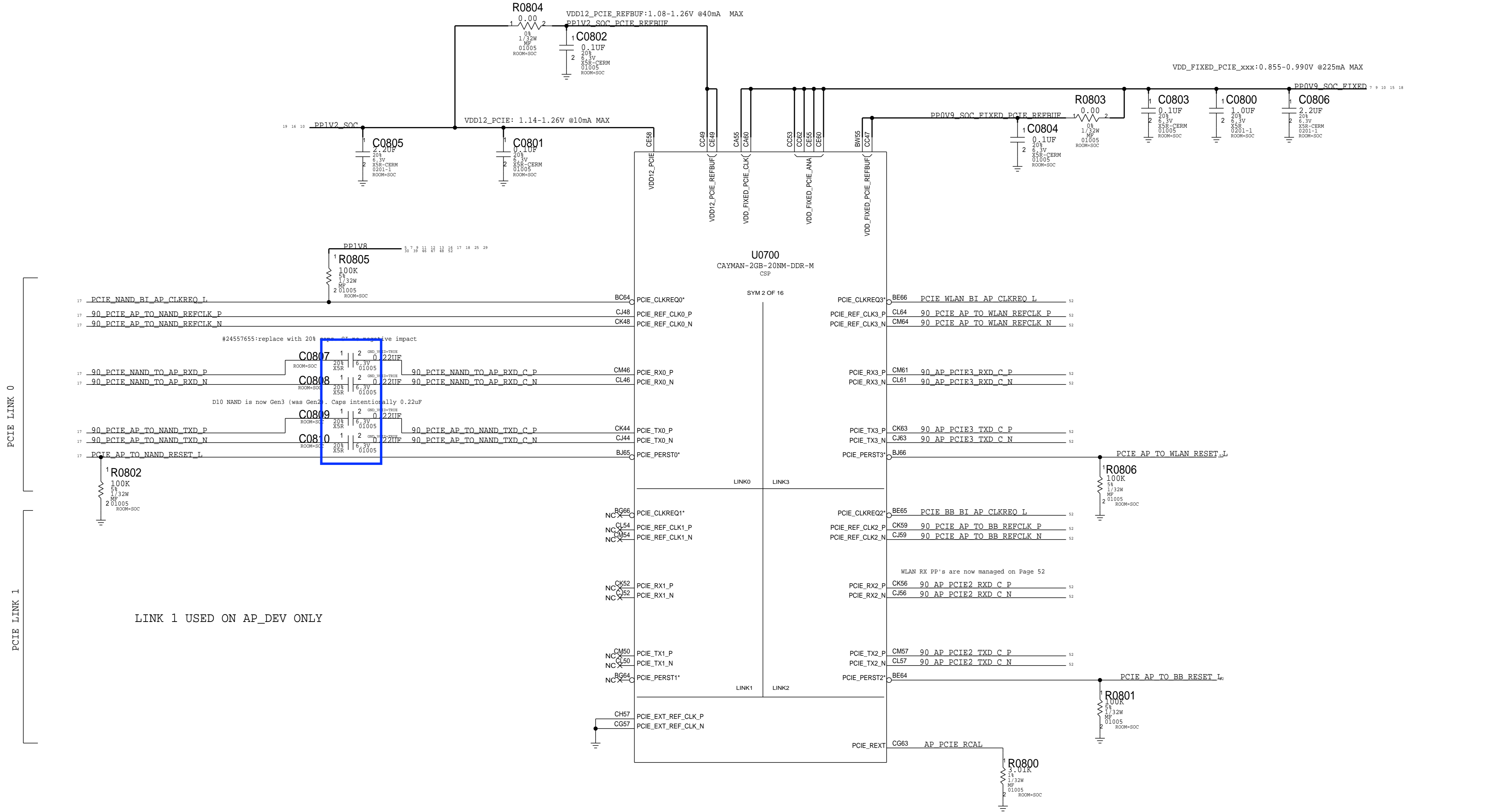

PAGE TITLE			SOC:PCIE		
Apple Inc.		DRAWING NUMBER	051-00482	SIZE	D
		REVISION	8.0.0		
NOTICE OF PROPRIETARY PROPERTY:		BRANCH			
THE INFORMATION CONTAINED HEREIN IS THE PROPRIETARY PROPERTY OF APPLE INC. THE POSSESSOR AGREES TO THE FOLLOWING:		PAGE	8 OF 53		
I TO MAINTAIN THIS DOCUMENT IN CONFIDENCE		SHEET	8 OF 81		
II NOT TO REPRODUCE OR COPY IT					
III NOT TO REVEAL OR PUBLISH IT IN WHOLE OR PART					
IV ALL RIGHTS RESERVED					

SOC - MIPI & ISP INTERFACES

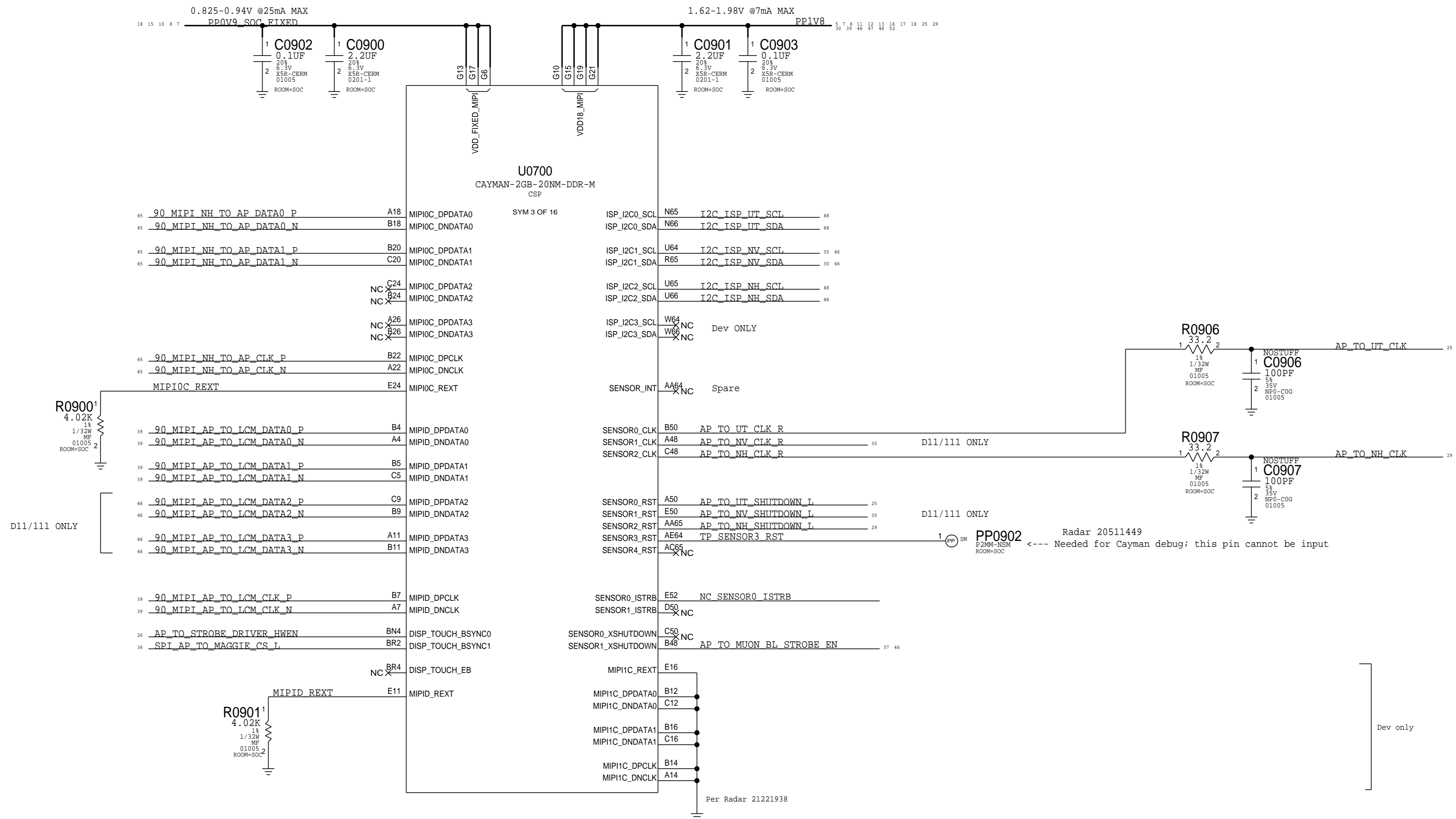

D11/111 ONLY

Dev only

Per Radar 21221938

AC return path for LCM MIPI which is referenced to GND and VDD_MAIN
Radar 21203307

PP0902 <--- Needed for Cayman debug; this pin cannot be input
Radar 20511449

PAGE TITLE		SOC:MIPI AND ISP	
Apple Inc.		DRAWING NUMBER	051-00482
		REVISION	8.0.0
NOTICE OF PROPRIETARY PROPERTY:		BRANCH	
THE INFORMATION CONTAINED HEREIN IS THE PROPRIETARY PROPERTY OF APPLE INC. THE POSSESSOR AGREES TO THE FOLLOWING:		PAGE	9 OF 53
I TO MAINTAIN THIS DOCUMENT IN CONFIDENCE		SHEET	9 OF 81
II NOT TO REPRODUCE OR COPY IT			
III NOT TO REVEAL OR PUBLISH IT IN WHOLE OR PART			
IV ALL RIGHTS RESERVED			

D

C

B

A

D

C

B

A

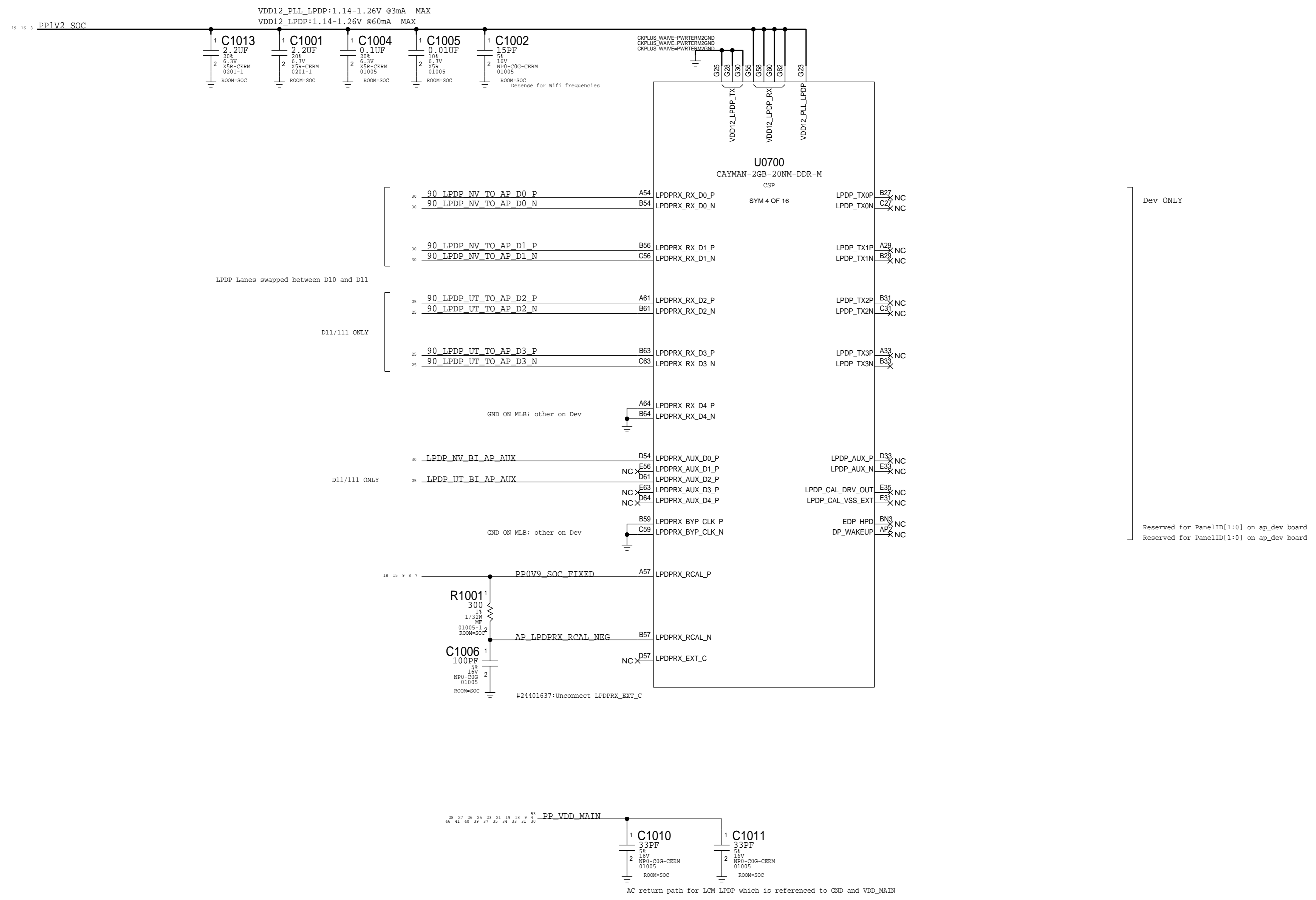

Dev ONLY

Reserved for PanelID[1:0] on ap_dev board
 Reserved for PanelID[1:0] on ap_dev board

PAGE TITLE			SOC:LPDP	
Apple Inc.	DRAWING NUMBER	051-00482	SIZE	D
	REVISION	8.0.0		
NOTICE OF PROPRIETARY PROPERTY: THE INFORMATION CONTAINED HEREIN IS THE PROPRIETARY PROPERTY OF APPLE INC. THE POSSESSOR AGREES TO THE FOLLOWING: I TO MAINTAIN THIS DOCUMENT IN CONFIDENCE II NOT TO REPRODUCE OR COPY IT III NOT TO REVEAL OR PUBLISH IT IN WHOLE OR PART IV ALL RIGHTS RESERVED			BRANCH	
			PAGE	10 OF 53
			SHEET	10 OF 81

SOC - SERIAL INTERFACES

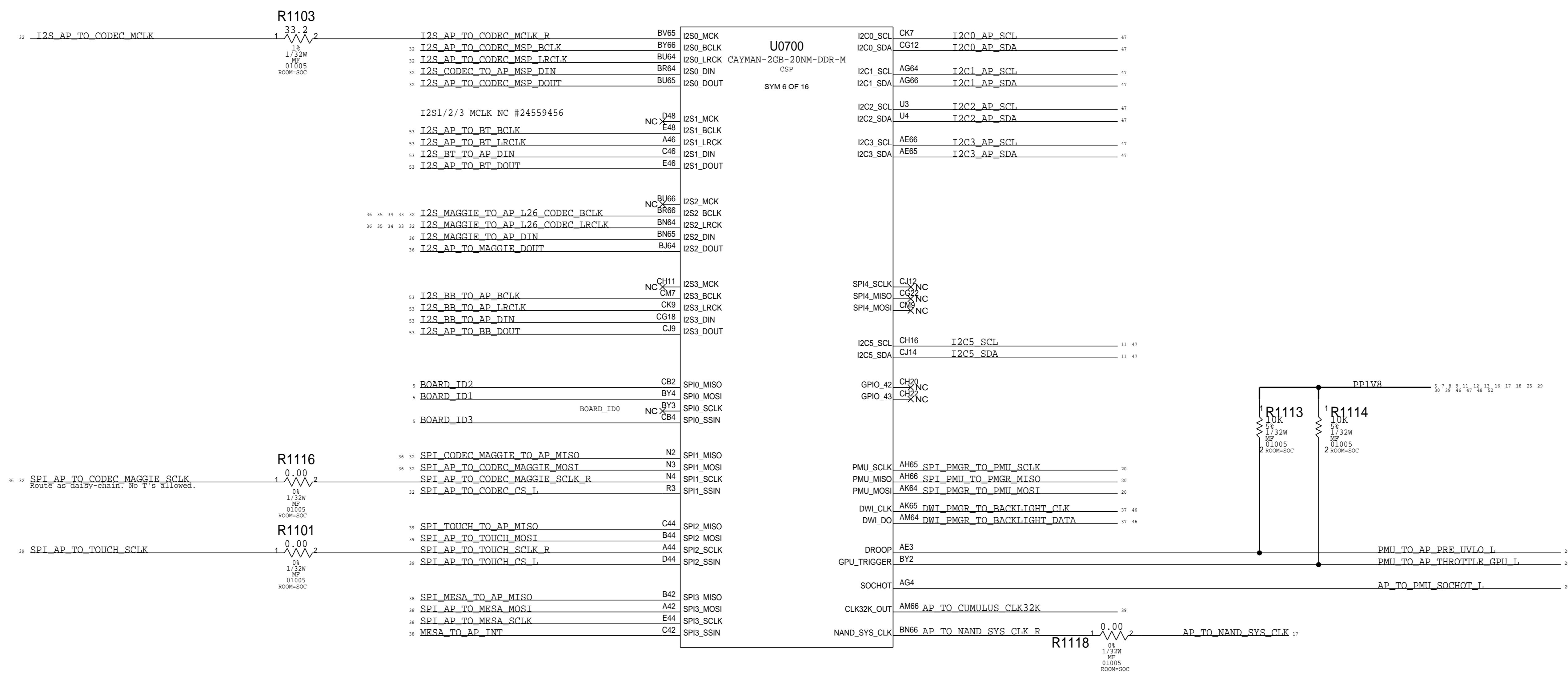

I2C5
See Radar#25316444 for Details

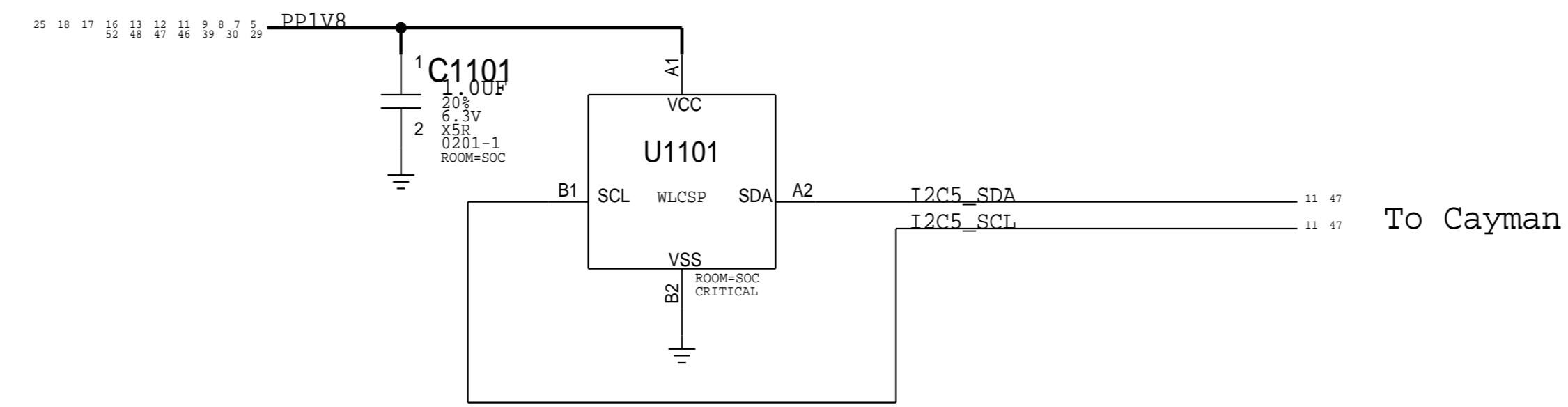

PAGE TITLE		SOC: SERIAL	
Apple Inc.		DRAWING NUMBER	051-00482
		REVISION	8.0.0
NOTICE OF PROPRIETARY PROPERTY: THE INFORMATION CONTAINED HEREIN IS THE PROPRIETARY PROPERTY OF APPLE INC. THE POSSESSOR AGREES TO THE FOLLOWING: I TO MAINTAIN THIS DOCUMENT IN CONFIDENCE II NOT TO REPRODUCE OR COPY IT III NOT TO REVEAL OR PUBLISH IT IN WHOLE OR PART IV ALL RIGHTS RESERVED		BRANCH	
		PAGE	11 OF 53
		SHEET	11 OF 81

system on chip
SOC - GPIO INTERFACES

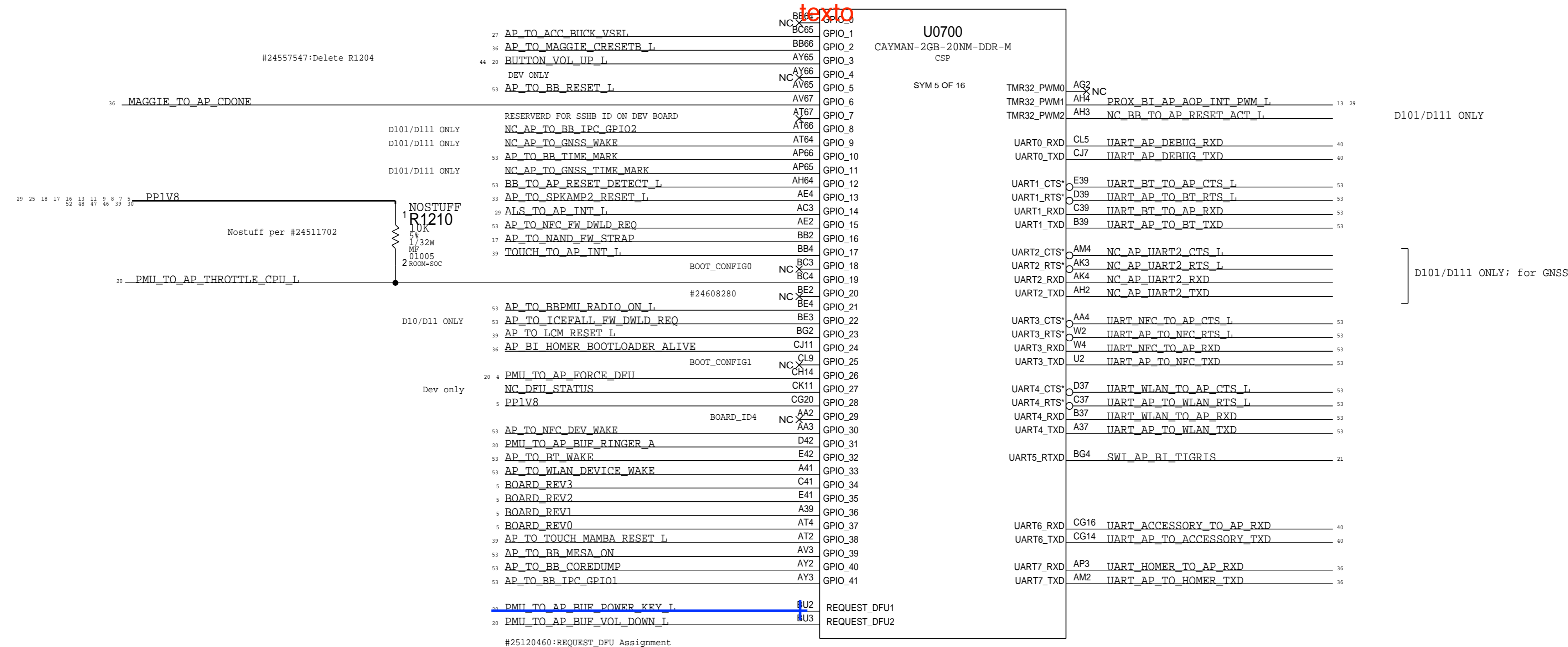

PAGE TITLE		SOC:GPIO & UART	
Apple Inc.	DRAWING NUMBER	051-00482	SIZE
	REVISION	8.0.0	D
NOTICE OF PROPRIETARY PROPERTY: THE INFORMATION CONTAINED HEREIN IS THE PROPRIETARY PROPERTY OF APPLE INC. THE POSSESSOR AGREES TO THE FOLLOWING: I TO MAINTAIN THIS DOCUMENT IN CONFIDENCE II NOT TO REPRODUCE OR COPY IT III NOT TO REVEAL OR PUBLISH IT IN WHOLE OR PART IV ALL RIGHTS RESERVED		BRANCH	
		PAGE	12 OF 53
		SHEET	12 OF 81

SOC - AOP

#24512059: Remove R1300 PU
Use internal pullup in SOC (AOP side).

Plan to use internal pullup in AOP. Radar 21210869

#25756894:North Carbon R1

#25756894:South Carbon R2

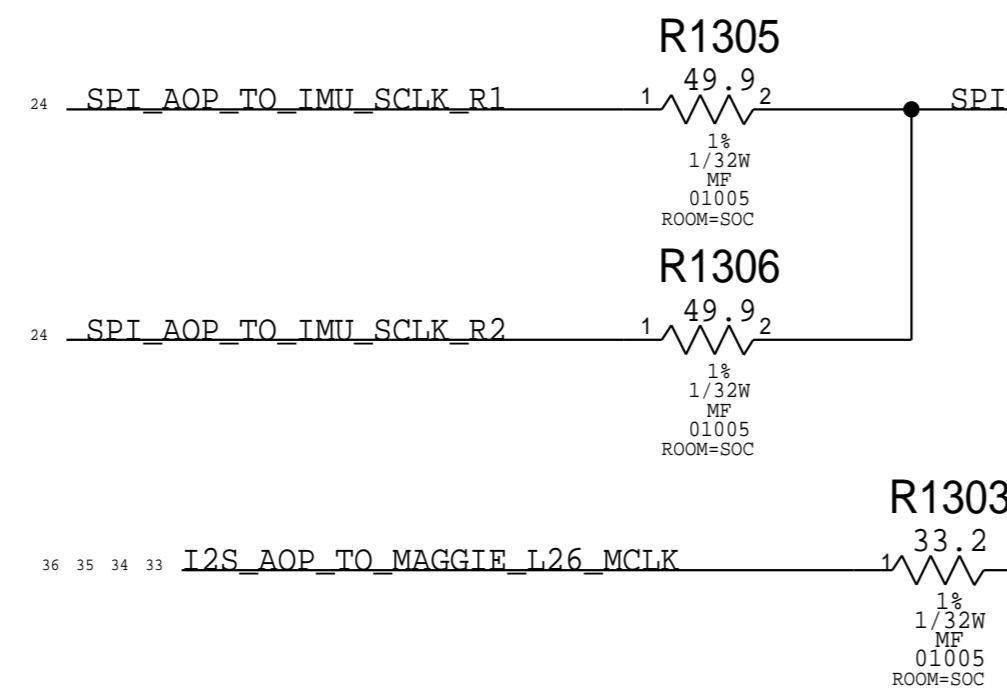

20	_AOP_TO_PMU_SLEEP1_REQUEST	CM16	AOP_DDR_REQ
20	_PMU_TO_AOP_SLEEP1_READY	CM29	AOP_DDR_RESET
24	_SPI_AOP_TO_COMPASS_CS_L	CK12	AOP_FUNC_0
24	_COMPASS_TO_AOP_INT	CK16	AOP_FUNC_1
29	12 PROX_BI_AP_AOP_INT_PWM_L	CK18	AOP_FUNC_2
24	_ACCEL_GYRO_TO_AOP_DATARDY	CJ29	AOP_FUNC_3
24	_SPI_AOP_TO_ACCEL_GYRO_CS_L	CG31	AOP_FUNC_4
24	_ACCEL_GYRO_TO_AOP_INT	CH31	AOP_FUNC_5
24	_SPI_AOP_TO_PHOSPHORUS_CS_L	CK20	AOP_FUNC_6
53 39 23	_LCM_TO_MANY_BSYN	CJ31	AOP_FUNC_7
40	_TRISTAR_TO_AOP_INT	CK27	AOP_FUNC_8
36	_AOP_TO_MAGGIE_EN	CK24	AOP_FUNC_9
24	_PHOSPHORUS_TO_AOP_INT_L	CK29	AOP_FUNC_10
24	_SPI_AOP_TO_BOT_ACCEL_GYRO_CS_L	CK22	AOP_FUNC_11
24	_BOT_ACCEL_GYRO_TO_AOP_DATARDY	CM12	AOP_FUNC_12
35 34 33	_AUDIO_TO_AOP_INT_L	CK31	AOP_FUNC_13
48	_AOP_TO_MESA_I2C_ISO_EN	CG33	AOP_FUNC_14
20	_PMU_TO_AOP_IRQ_L	CJ33	AOP_FUNC_15
48	_I2C_AOP_SCL	CM11	AOP_I2C0_SCL
48	_I2C_AOP_SDA	CJ24	AOP_I2C0_SDA
24	_SPT_IMU_TO_AOP_MISO	CJ18	AOP_SPI_MISO
24	_SPT_AOP_TO_IMU_MOST	CJ27	AOP_SPI_MOSI
24	_SPT_AOP_TO_IMU_SCLK	CJ16	AOP_SPI_SCLK
53	_UART_BB_TO_AOP_RXD	CK14	AOP_UART0_RXD
53	_UART_AOP_TO_BB_TXD	CJ20	AOP_UART0_TXD
16	_MAGGIE_TO_AOP_INT	CJ22	AOP_UART1_RXD
16	_UART_AOP_TO_MAGGIE_TXD	CL11	AOP_UART1_TXD
39	_UART_TOUCH_TO_AOP_RXD	CG29	AOP_UART2_RXD
39	_UART_AOP_TO_TOUCH_TXD	CH29	AOP_UART2_TXD
32	_I2S_CODEX_XSP_TO_AOP_BCLK	CL35	AOP_I2S_BCLK
32	_I2S_CODEX_XSP_TO_AOP_DIN	CJ39	AOP_I2S_DIN
32	_I2S_AOP_TO_MAGGIE_I26_MCLK_R	CM35	AOP_I2S_MCK
32	_I2S_CODEX_XSP_TO_AOP_LRCLK	CK37	AOP_I2S_LRCK
32	_I2S_AOP_TO_CODEX_XSP_DOUT	CG39	AOP_I2S_DOUT

U0700

CAYMAN-2GB-20NM-DDR-M
CSP

SYM 7 OF 16

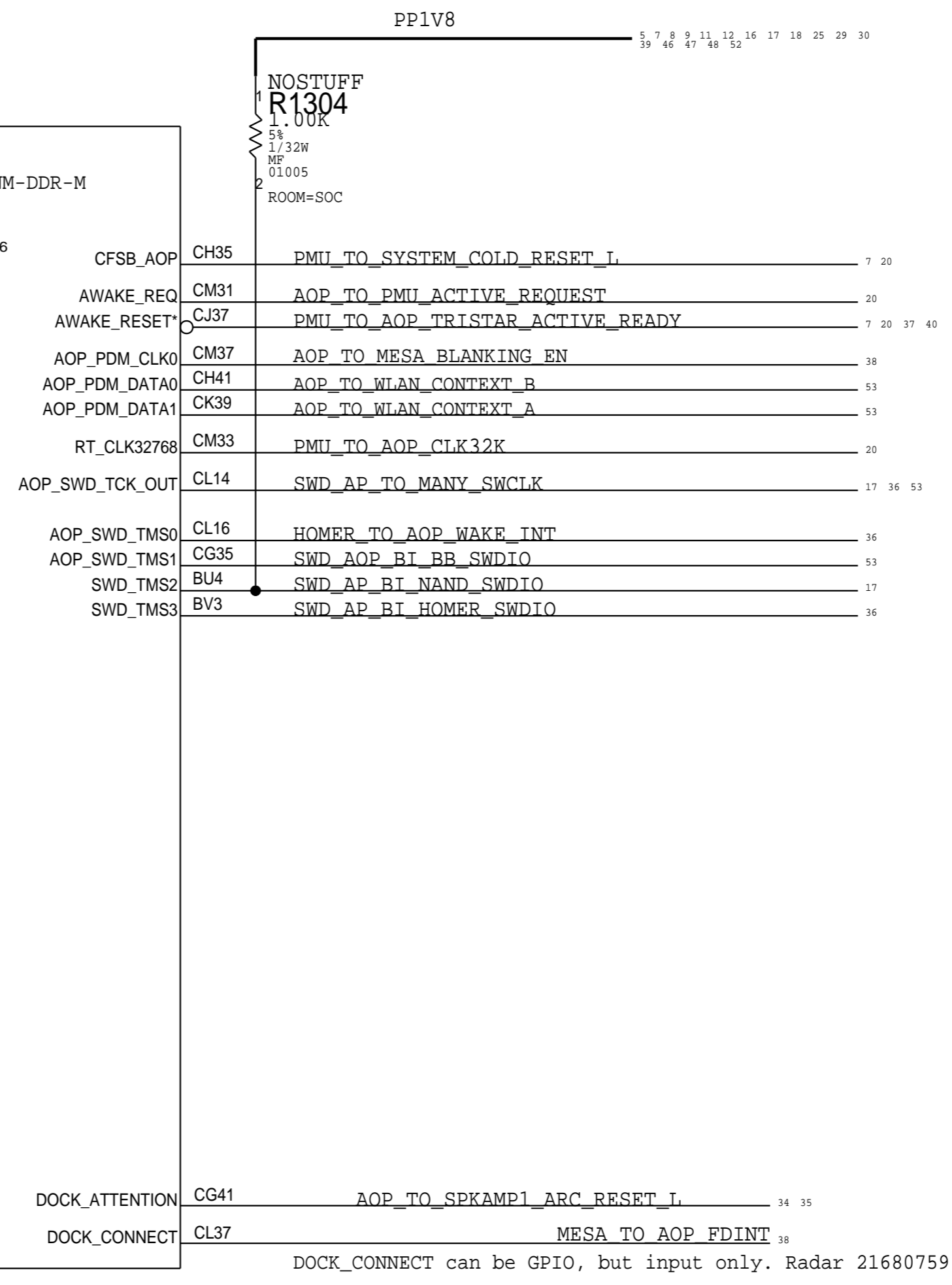

BB_SWDIO has pullup in Radio_ML8 pages

DOCK_CONNECT can be GPIO, but input only. Radar 21680759

PAGE TITLE		SOC:AOP	
	DRAWING NUMBER	051-00482	SIZE
	REVISION	8.0.0	D
NOTICE OF PROPRIETARY PROPERTY: THE INFORMATION CONTAINED HEREIN IS THE PROPRIETARY PROPERTY OF APPLE INC. THE POSSESSOR AGREES TO THE FOLLOWING: I TO MAINTAIN THIS DOCUMENT IN CONFIDENCE II NOT TO REPRODUCE OR COPY IT III NOT TO REVEAL OR PUBLISH IT IN WHOLE OR PART IV ALL RIGHTS RESERVED		BRANCH	
		PAGE	13 OF 53
		SHEET	13 OF 81

SOC - CPU, GPU & SOC RAILS

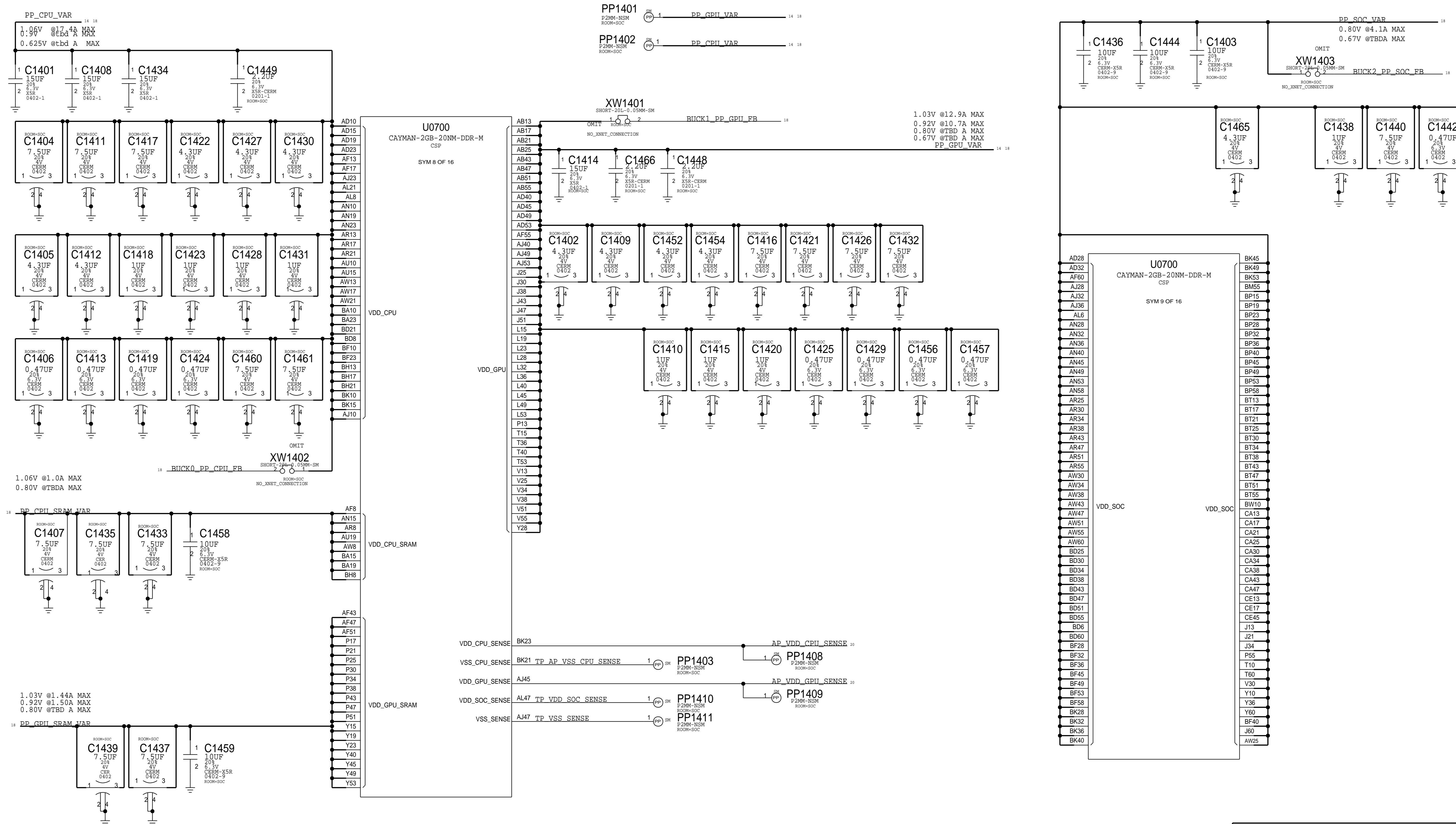

SOC - POWER SUPPLIES

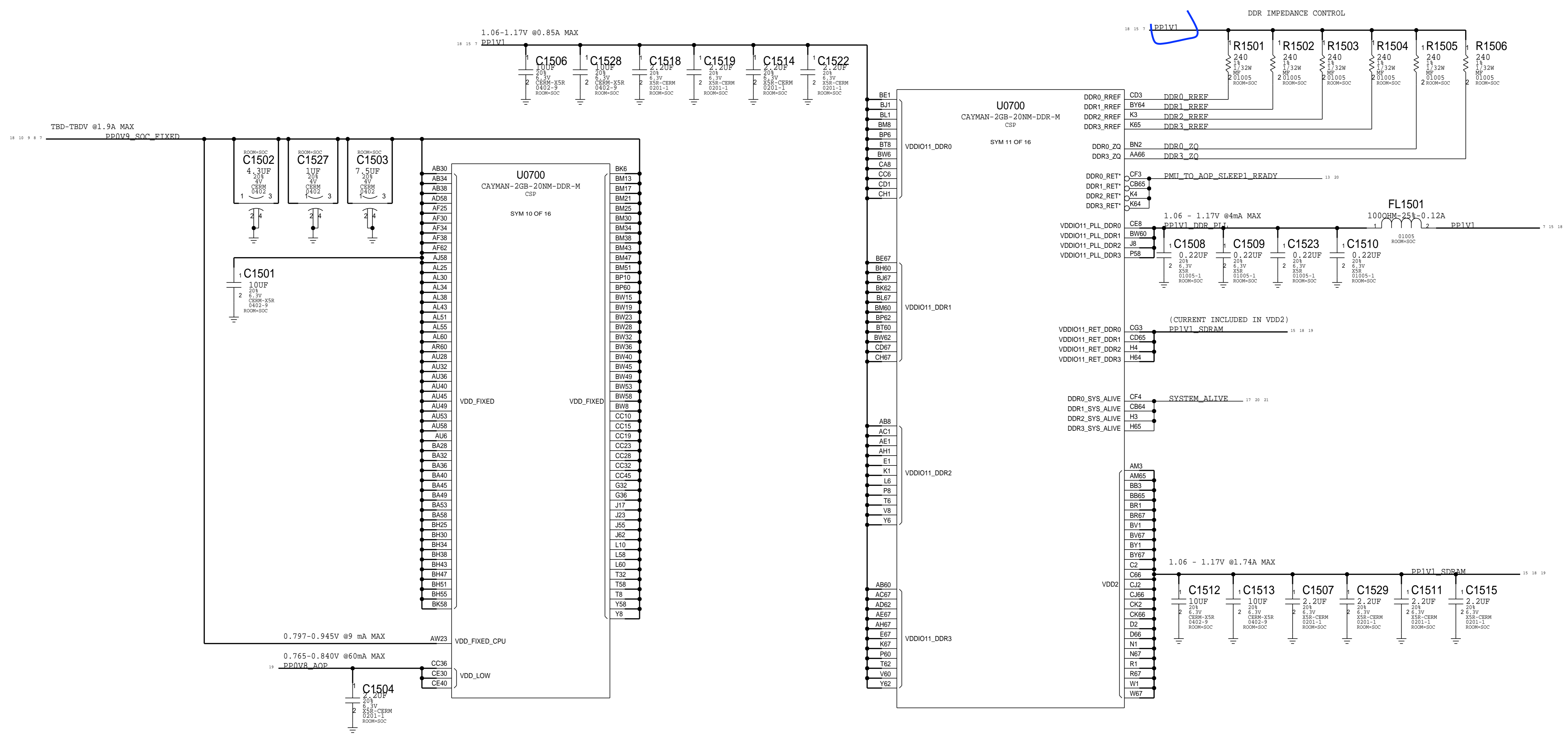

PAGE TITLE		SOC: POWER (2/3)	
Apple Inc.	DRAWING NUMBER	051-00482	SIZE
	REVISION	8.0.0	D
NOTICE OF PROPRIETARY PROPERTY: THE INFORMATION CONTAINED HEREIN IS THE PROPRIETARY PROPERTY OF APPLE INC. THE POSSESSOR AGREES TO THE FOLLOWING: I TO MAINTAIN THIS DOCUMENT IN CONFIDENCE II NOT TO REPRODUCE OR COPY IT III NOT TO REVEAL OR PUBLISH IT IN WHOLE OR PART IV ALL RIGHTS RESERVED		BRANCH	
		PAGE	15 OF 53
		SHEET	15 OF 81

SOC - POWER SUPPLIES

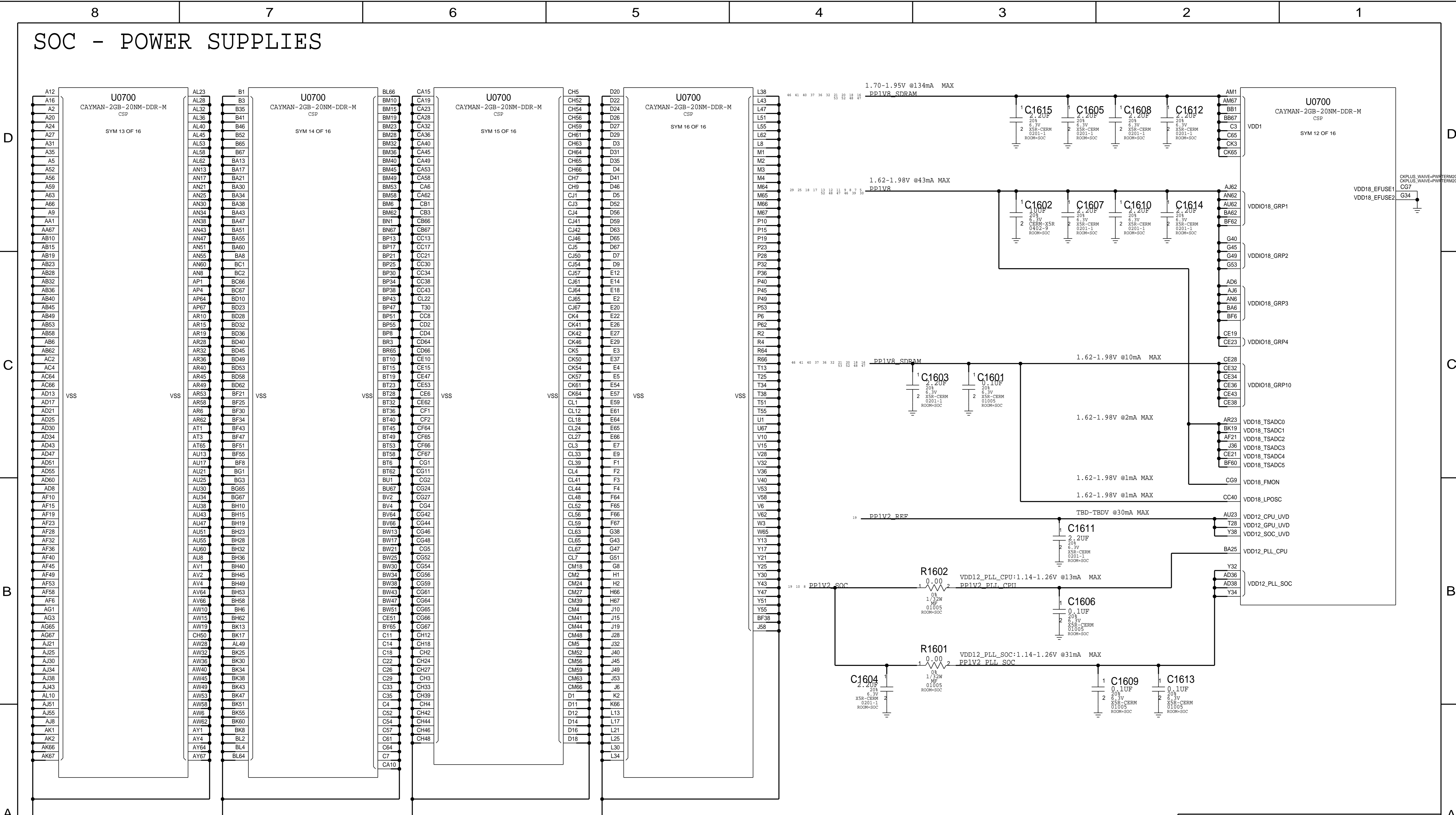

PAGE TITLE		SOC-POWER (3/3)	
Apple Inc.		DRAWING NUMBER	051-00482
		REVISION	8.0.0
NOTICE OF PROPRIETARY PROPERTY:		BRANCH	
THE INFORMATION CONTAINED HEREIN IS THE PROPRIETARY PROPERTY OF APPLE INC. THE POSSESSOR AGREES TO THE FOLLOWING: I TO MAINTAIN THIS DOCUMENT IN CONFIDENCE II NOT TO REPRODUCE OR COPY IT III NOT TO REVEAL OR PUBLISH IT IN WHOLE OR PART IV ALL RIGHTS RESERVED		PAGE	16 OF 53
		SHEET	16 OF 81

D

C

B

A

D

C

B

A

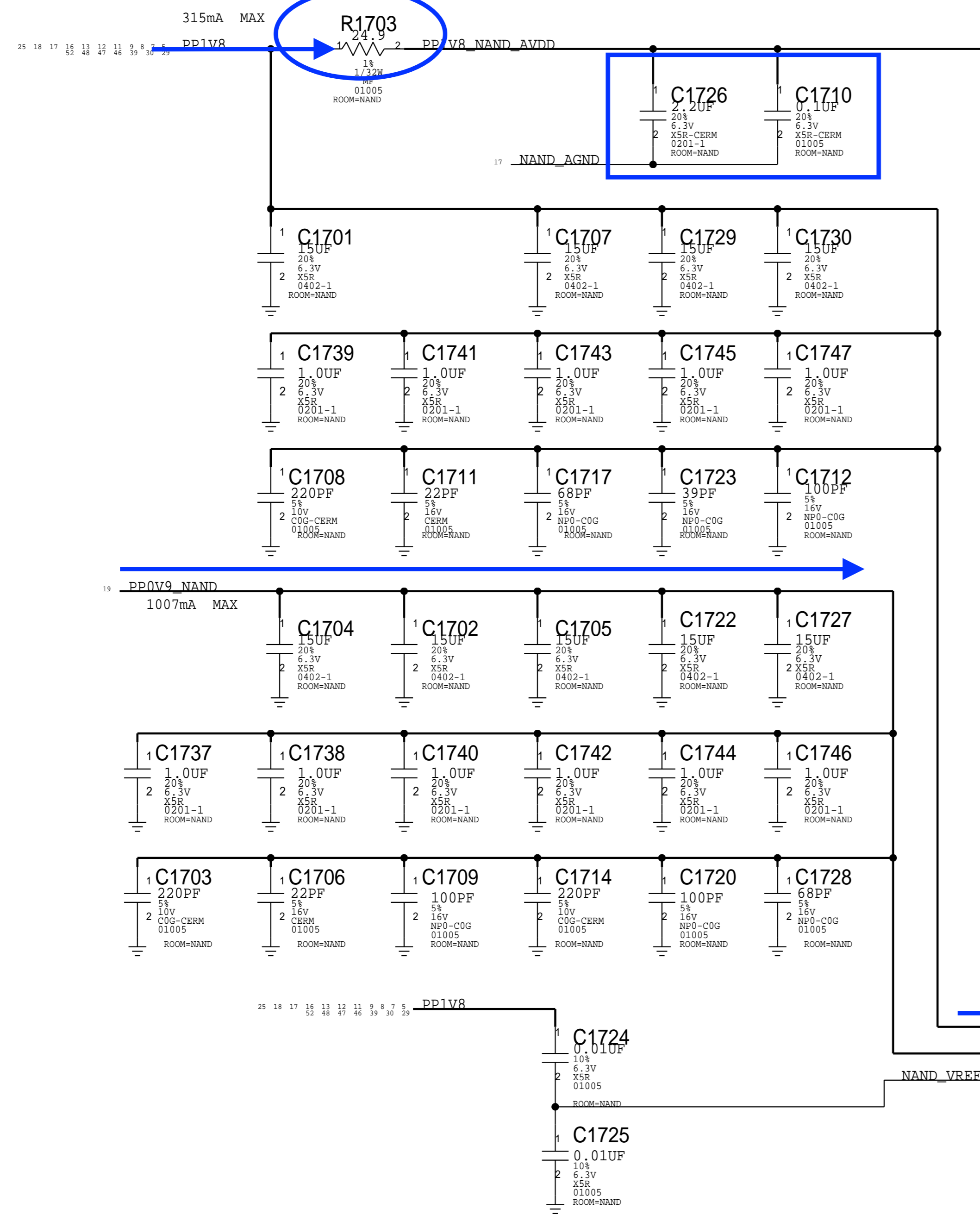

PROBE POINTS

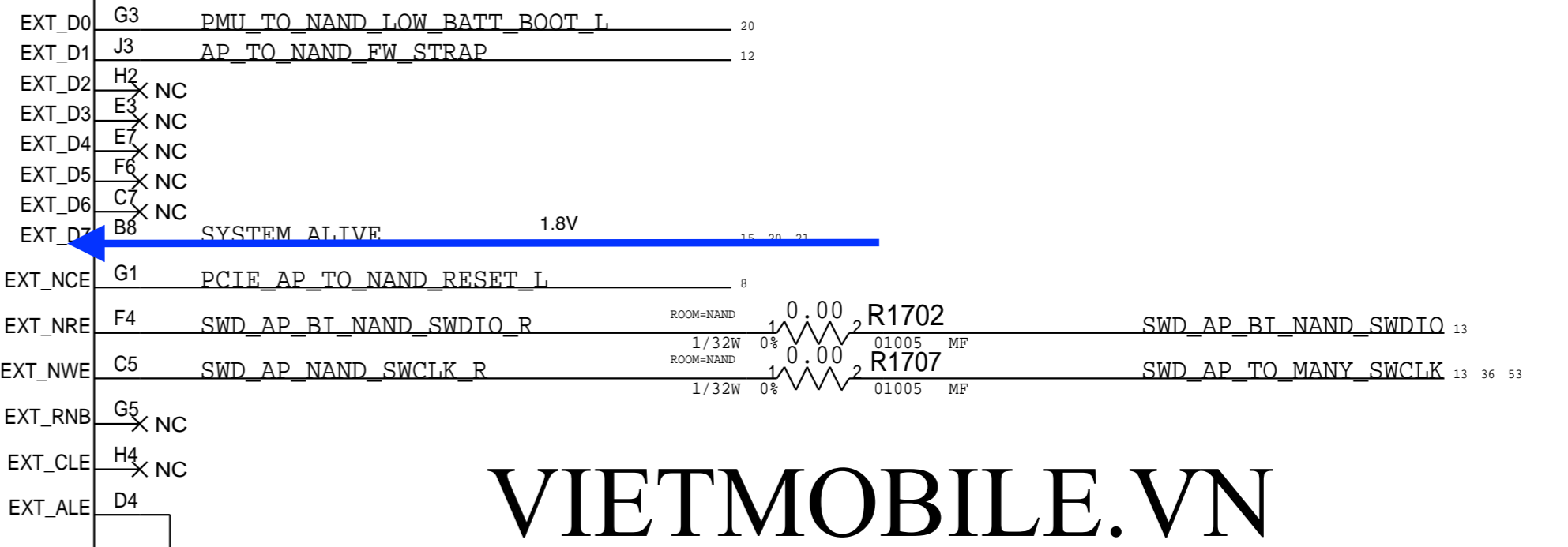
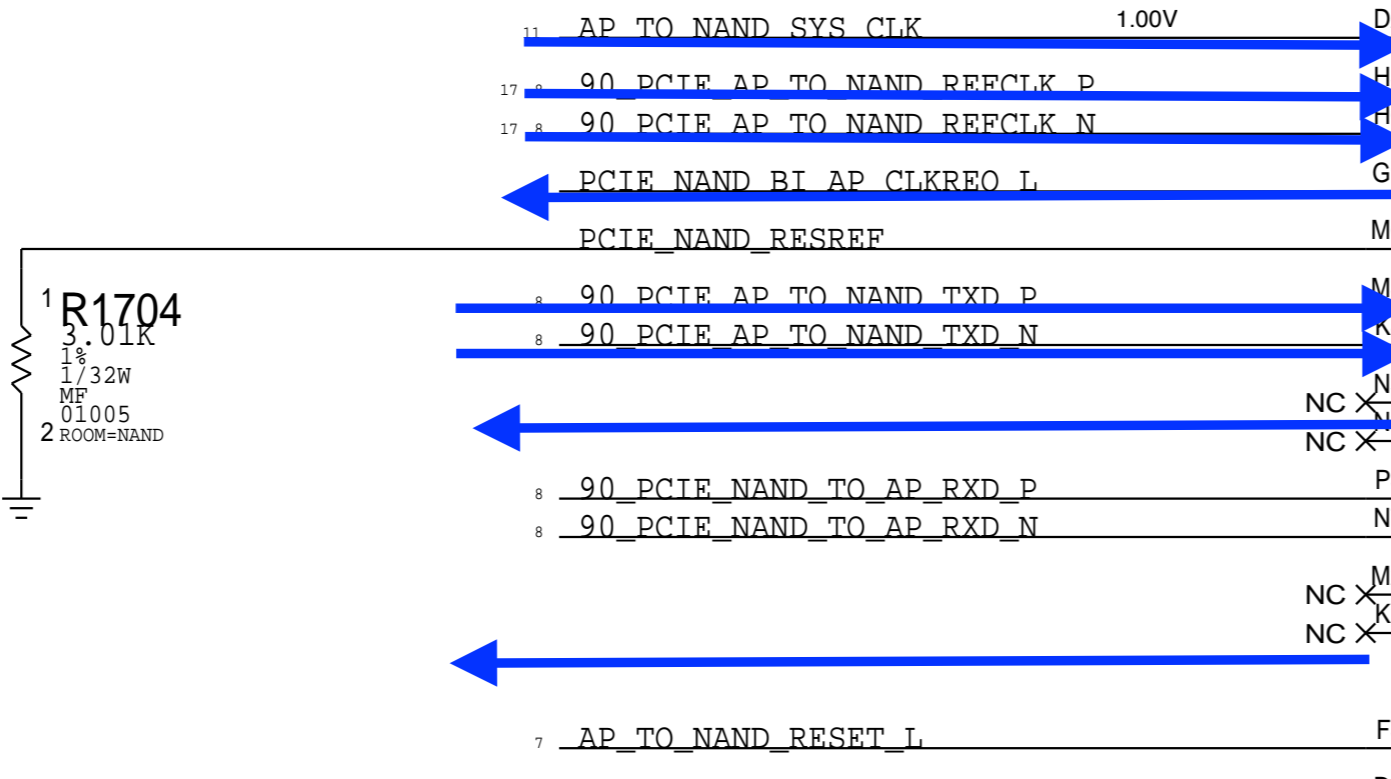
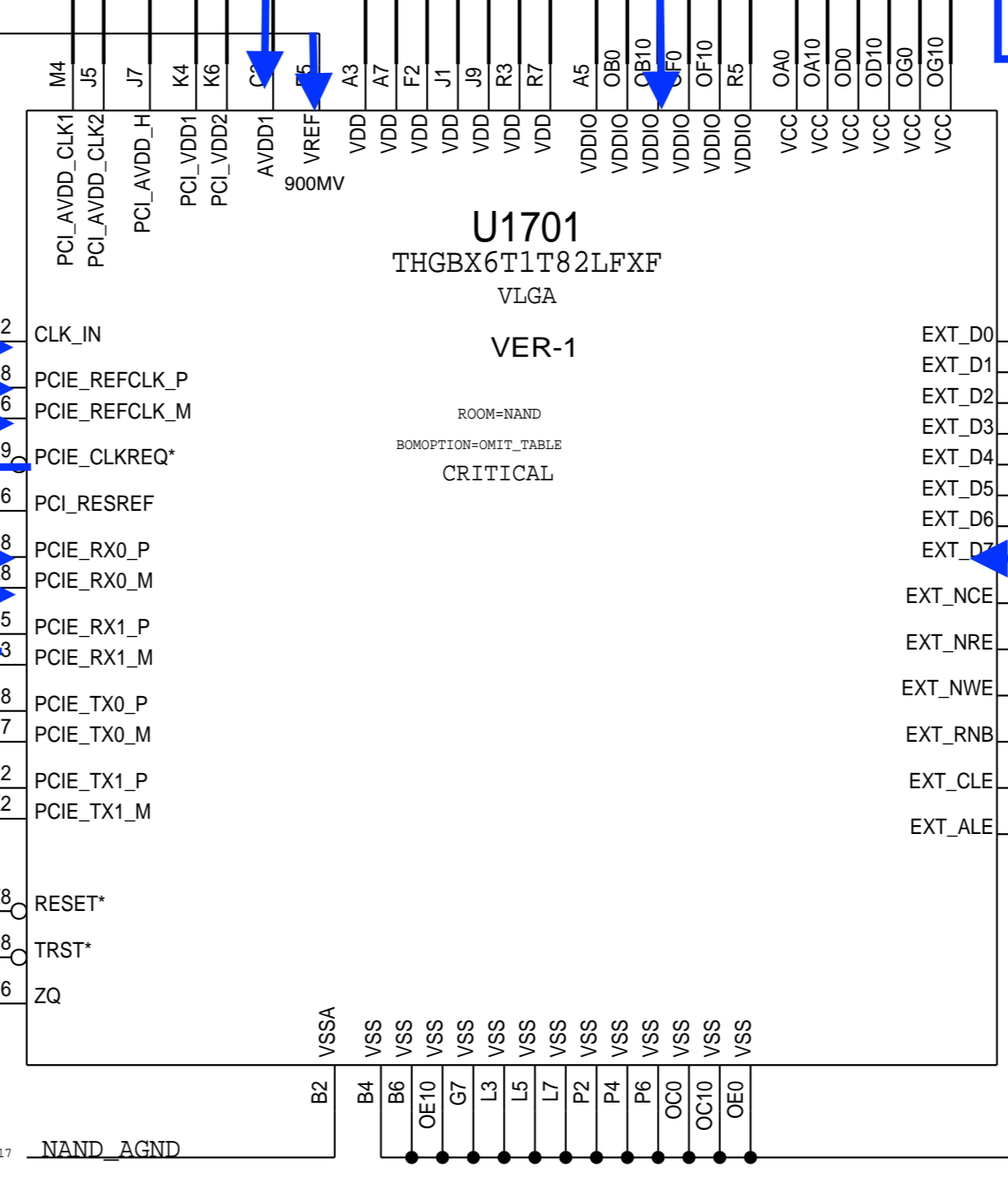
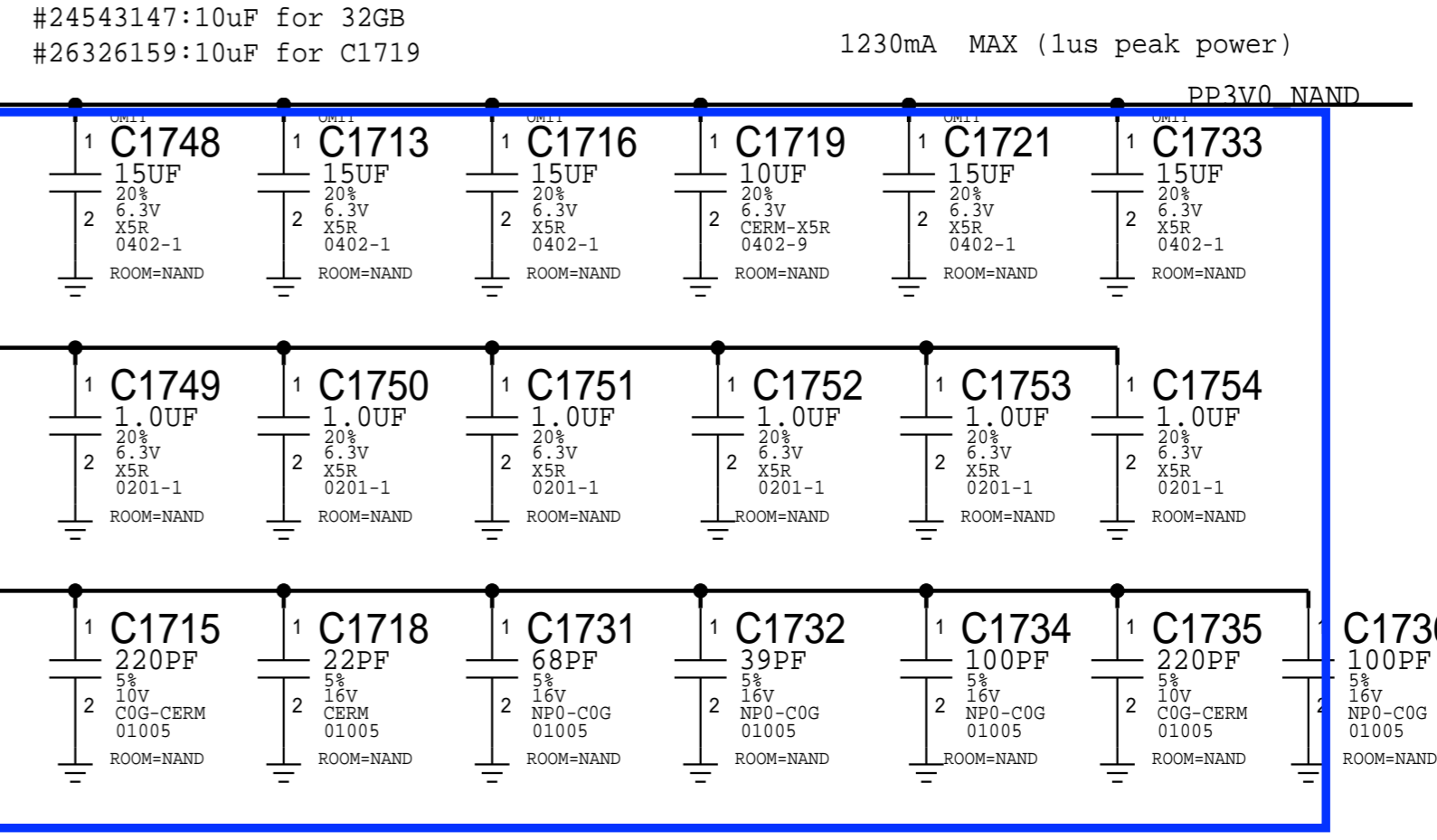
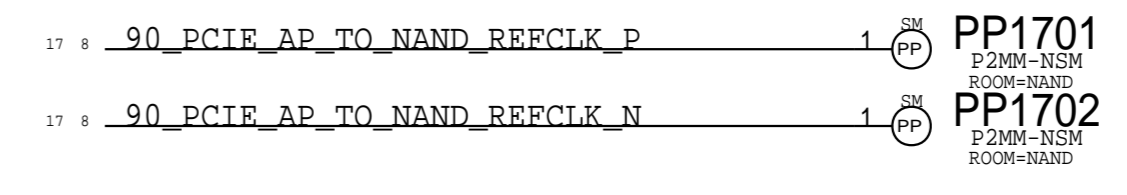

VIETMOBILE.VN

PAGE TITLE		NAND	
Apple Inc.		DRAWING NUMBER	051-00482
		REVISION	8.0.0
NOTICE OF PROPRIETARY PROPERTY:		BRANCH	
THE INFORMATION CONTAINED HEREIN IS THE PROPRIETARY PROPERTY OF APPLE INC. THE POSSESSOR AGREES TO THE FOLLOWING:		PAGE	17 OF 53
I TO MAINTAIN THIS DOCUMENT IN CONFIDENCE		SHEET	17 OF 81
II NOT TO REPRODUCE OR COPY IT			
III NOT TO REVEAL OR PUBLISH IT IN WHOLE OR PART			
IV ALL RIGHTS RESERVED			

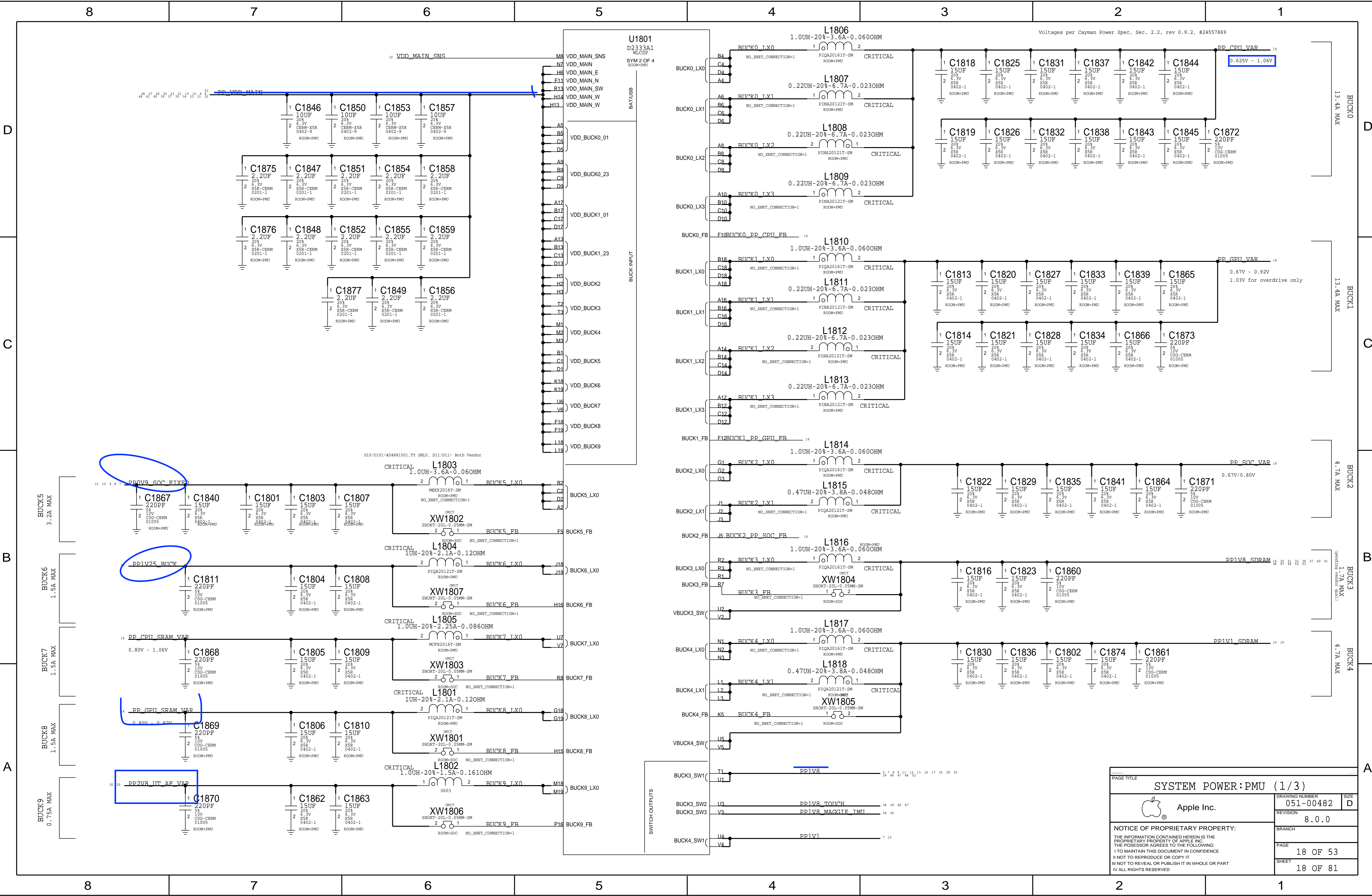

PAGE TITLE		SYSTEM POWER:PMU (1/3)	
Apple Inc.		DRAWING NUMBER	051-00482
		REVISION	8.0.0
NOTICE OF PROPRIETARY PROPERTY:		BRANCH	
THE INFORMATION CONTAINED HEREIN IS THE PROPRIETARY PROPERTY OF APPLE INC. THE POSSESSOR AGREES TO THE FOLLOWING:		PAGE	18 OF 53
I TO MAINTAIN THIS DOCUMENT IN CONFIDENCE		SHEET	18 OF 81
II NOT TO REPRODUCE OR COPY IT			
III NOT TO REVEAL OR PUBLISH IT IN WHOLE OR PART			
IV ALL RIGHTS RESERVED			

ADELYN LDO SPECS

LDO#	ADJ. RANGE, LOW	ADJ. RANGE, HI	ACCURACY	MAX. CURRENT
LD01 (Ca)	1.2-2.475V	2.4-3.675V	+/-1.4%	50mA
LD02 (Ca)	1.2-2.475V	2.4-3.675V	+/-2.5%	50mA
LD03 (Ca)	1.2-2.475V	2.4-3.675V	+/-2.5%	50mA
LD04 (D)	0.7-1.2V		+/-2.5%	60mA
LD05 (F)	2.5-3.6V(tbc)		+/-75mV	1000mA
LD06 (Cb)	1.2-2.475V	2.4-3.675V	+/-2.5%	250mA (500/100mA in bypass)
LD07 (Cb)	1.2-2.475V	2.4-3.675V	+/-30mV	250mA
LD08 (Cb)	1.2-2.475V	2.4-3.675V	+/-30mV	250mA
LD09 (Cb)	1.2-2.475V	2.4-3.675V	+/-25mV	250mA
LD010 (Ga)	0.7-1.2V		+/-4.5%	1150mA

LDO#	ADJ. RANGE, LOW	ADJ. RANGE, HI	ACCURACY	MAX. CURRENT
LD011 (Cb)	1.2-2.475V	2.4-3.675V	+/-30mV	250mA
LD012 (E)	1.8V		+/-5%	10mA
LD013 (Cb)	1.2-2.475V	2.4-3.675V	+/-30mV	250mA
LD014 (Gb)	0.7-1.4V		+/-3.0%	400mA
LD015 (Ca)	1.2-2.475V	2.4-3.675V	+/-2.5%	50mA
LD016 (Cb)	1.2-2.475V	2.4-3.675V	+/-30mV	250mA
LD017 (Ca)	1.2-2.475V	2.4-3.675V	+/-2.5%	50mA
LD018 (Gb)	0.7-1.4V		+/-3.0%	400mA
LD019 (Gb)	0.7-1.4V		+/-3.0%	400mA
LDO_RTC	2.5V		+/-2.0%	10mA
BUF_1V2	1.2V		+/-5.0%	10mA

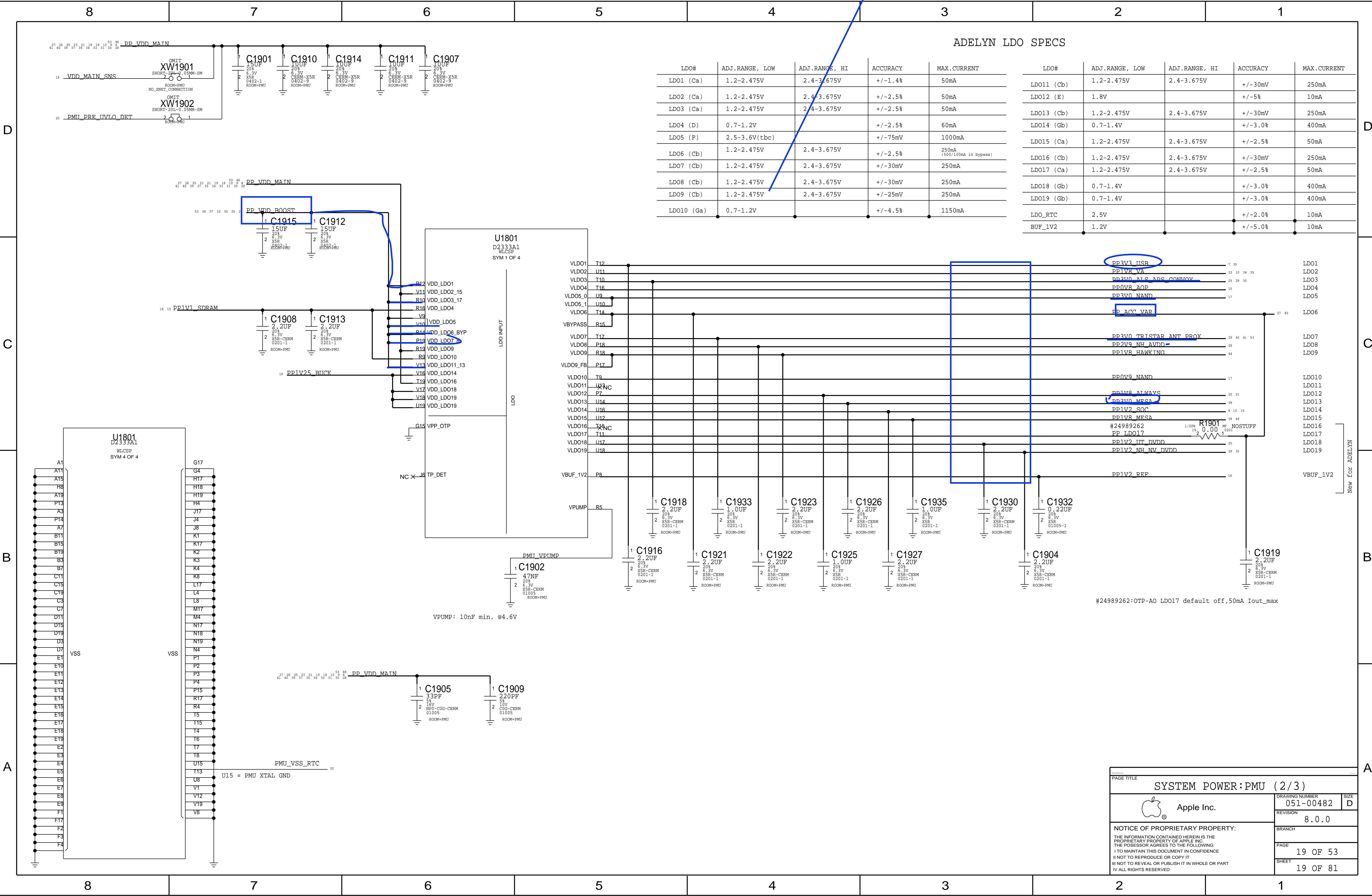

PAGE TITLE		SYSTEM POWER:PMU (2/3)	
DRAWING NUMBER		051-00482	SIZE D
REVISION		8.0.0	
BRANCH			
PAGE		19 OF 53	
SHEET		19 OF 81	

Apple Inc.

NOTICE OF PROPRIETARY PROPERTY:
 THE INFORMATION CONTAINED HEREIN IS THE PROPRIETARY PROPERTY OF APPLE INC. THE POSSESSOR AGREES TO THE FOLLOWING:
 I TO MAINTAIN THIS DOCUMENT IN CONFIDENCE
 II NOT TO REPRODUCE OR COPY IT
 III NOT TO REVEAL OR PUBLISH IT IN WHOLE OR PART
 IV ALL RIGHTS RESERVED

D

C

B

A

BUTTON PULL-UP RESISTORS

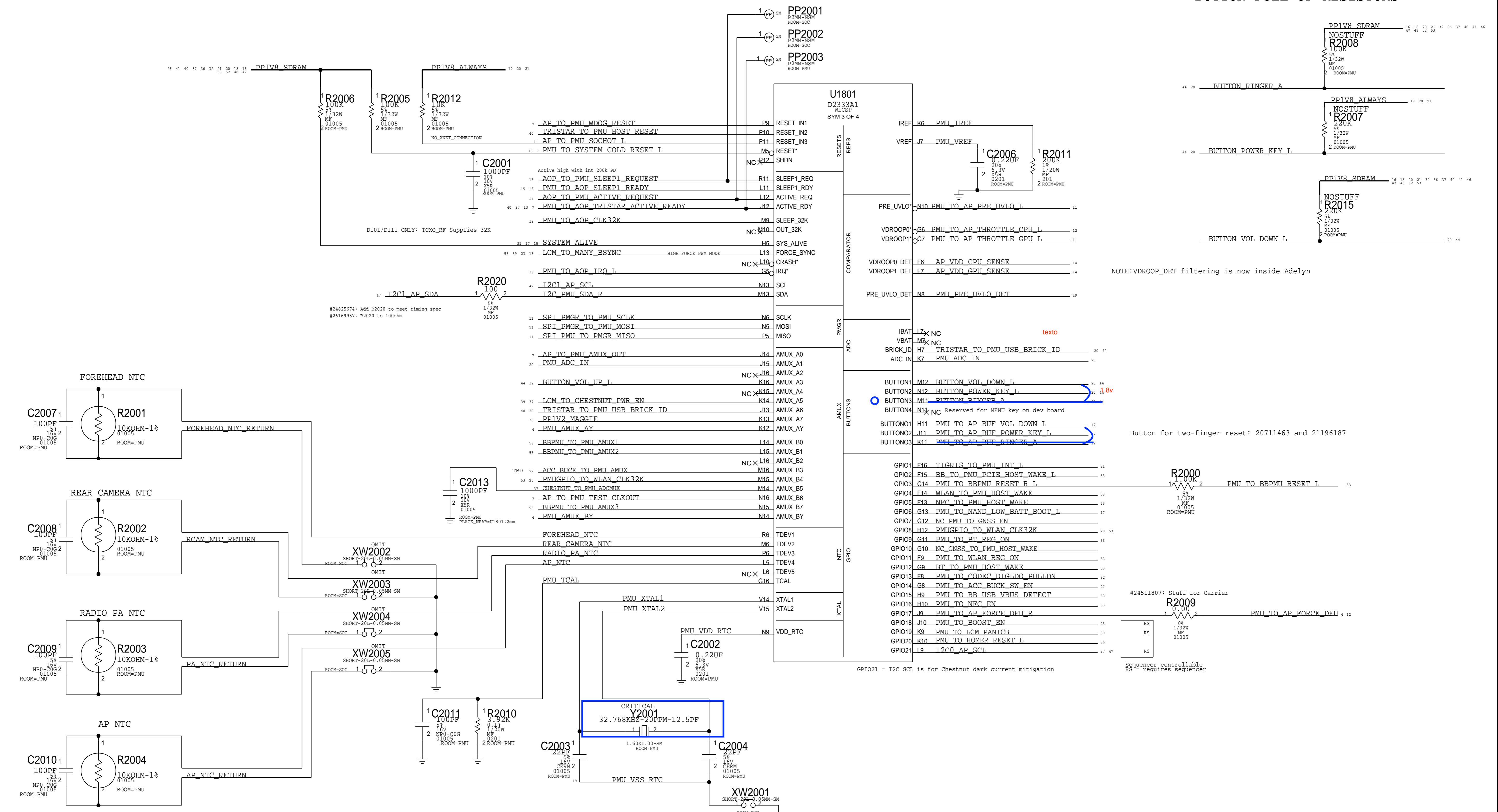

NOTE: VDROOP_DET filtering is now inside Adelyn

Button for two-finger reset: 20711463 and 21196187

#24511807: Stuff for Carrier

Sequencer controllable RS = requires sequencer

NOTE: 100PF CAPS ARE THE SAMPLING CAPS FOR PMU ADC

PAGE TITLE		SYSTEM POWER:PMU (3/3)	
Apple Inc.	DRAWING NUMBER	051-00482	SIZE D
	REVISION	8.0.0	
NOTICE OF PROPRIETARY PROPERTY: THE INFORMATION CONTAINED HEREIN IS THE PROPRIETARY PROPERTY OF APPLE INC. THE POSSESSOR AGREES TO THE FOLLOWING: I TO MAINTAIN THIS DOCUMENT IN CONFIDENCE II NOT TO REPRODUCE OR COPY IT III NOT TO REVEAL OR PUBLISH IT IN WHOLE OR PART IV ALL RIGHTS RESERVED		BRANCH	
		PAGE	20 OF 53
		SHEET	20 OF 81

TIGRIS CHARGER

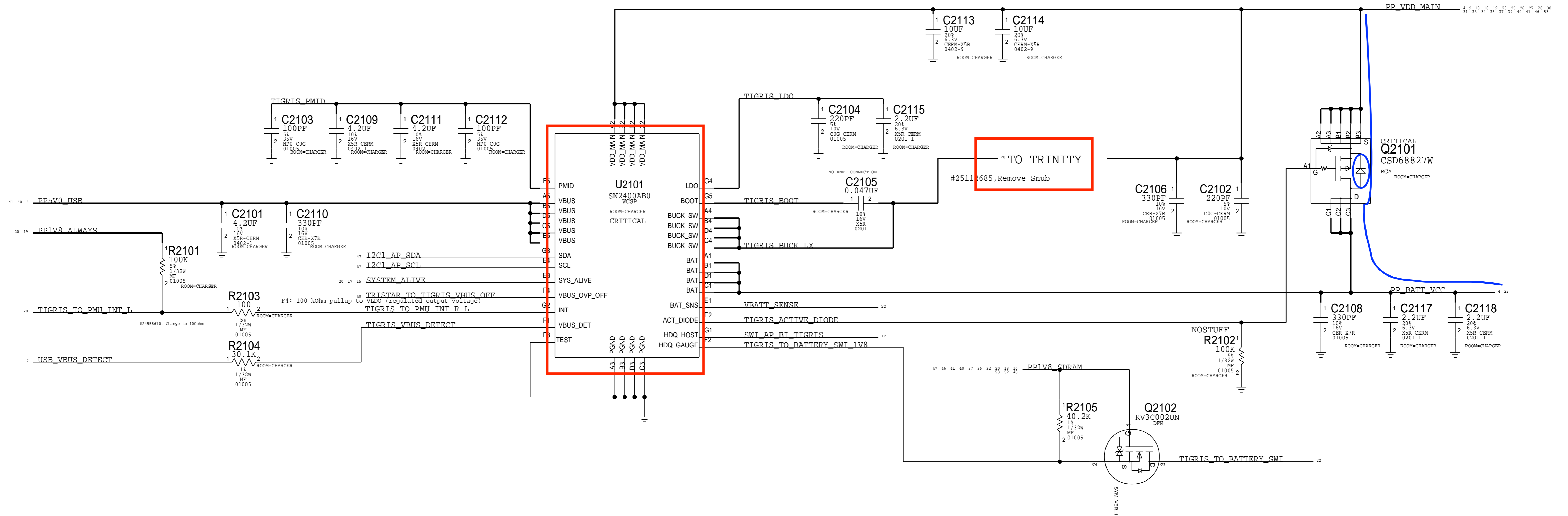

PAGE TITLE		
SYSTEM POWER:CHARGER		
	DRAWING NUMBER	051-00482
	REVISION	8.0.0
NOTICE OF PROPRIETARY PROPERTY:		
THE INFORMATION CONTAINED HEREIN IS THE PROPRIETARY PROPERTY OF APPLE INC. THE POSSESSOR AGREES TO THE FOLLOWING: I TO MAINTAIN THIS DOCUMENT IN CONFIDENCE II NOT TO REPRODUCE OR COPY IT III NOT TO REVEAL OR PUBLISH IT IN WHOLE OR PART IV ALL RIGHTS RESERVED		
BRANCH		
PAGE	21 OF 53	
SHEET	21 OF 81	

8

7

6

5

4

3

2

1

D

D

C

C

B

B

A

A

BATTERY CONNECTOR

THIS ONE ON MLB ---> 516S00172 (matches d10 m1b MCO rev 27)

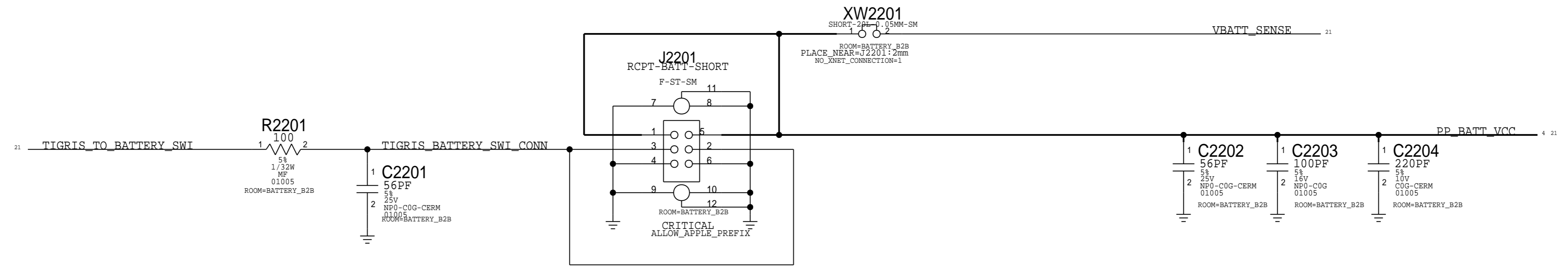

PAGE TITLE		SYSTEM POWER: BATTERY CONN	
	DRAWING NUMBER	051-00482	SIZE
	REVISION	8.0.0	D
NOTICE OF PROPRIETARY PROPERTY: THE INFORMATION CONTAINED HEREIN IS THE PROPRIETARY PROPERTY OF APPLE INC. THE POSSESSOR AGREES TO THE FOLLOWING: I TO MAINTAIN THIS DOCUMENT IN CONFIDENCE II NOT TO REPRODUCE OR COPY IT III NOT TO REVEAL OR PUBLISH IT IN WHOLE OR PART IV ALL RIGHTS RESERVED		BRANCH	
		PAGE	22 OF 53
		SHEET	22 OF 81

8

7

6

5

4

3

2

1

BOOST

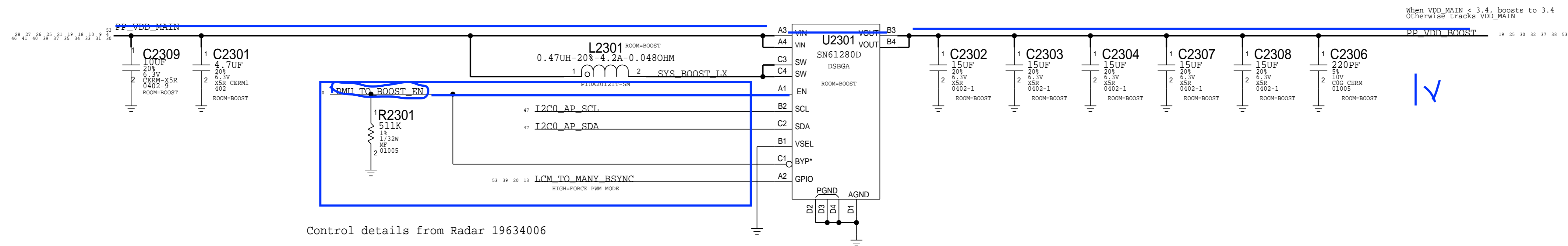

IV

PAGE TITLE			SYSTEM POWER: BOOST		
Apple Inc.		DRAWING NUMBER	051-00482	SIZE	D
		REVISION	8.0.0		
NOTICE OF PROPRIETARY PROPERTY:		BRANCH			
THE INFORMATION CONTAINED HEREIN IS THE PROPRIETARY PROPERTY OF APPLE INC. THE POSSESSOR AGREES TO THE FOLLOWING:		PAGE			
I TO MAINTAIN THIS DOCUMENT IN CONFIDENCE		23 OF 53			
II NOT TO REPRODUCE OR COPY IT		SHEET			
III NOT TO REVEAL OR PUBLISH IT IN WHOLE OR PART		23 OF 81			
IV ALL RIGHTS RESERVED					

CARBON - ACCEL & GYRO

INVENSENSE, MPU-6800: C2403=0.1UF

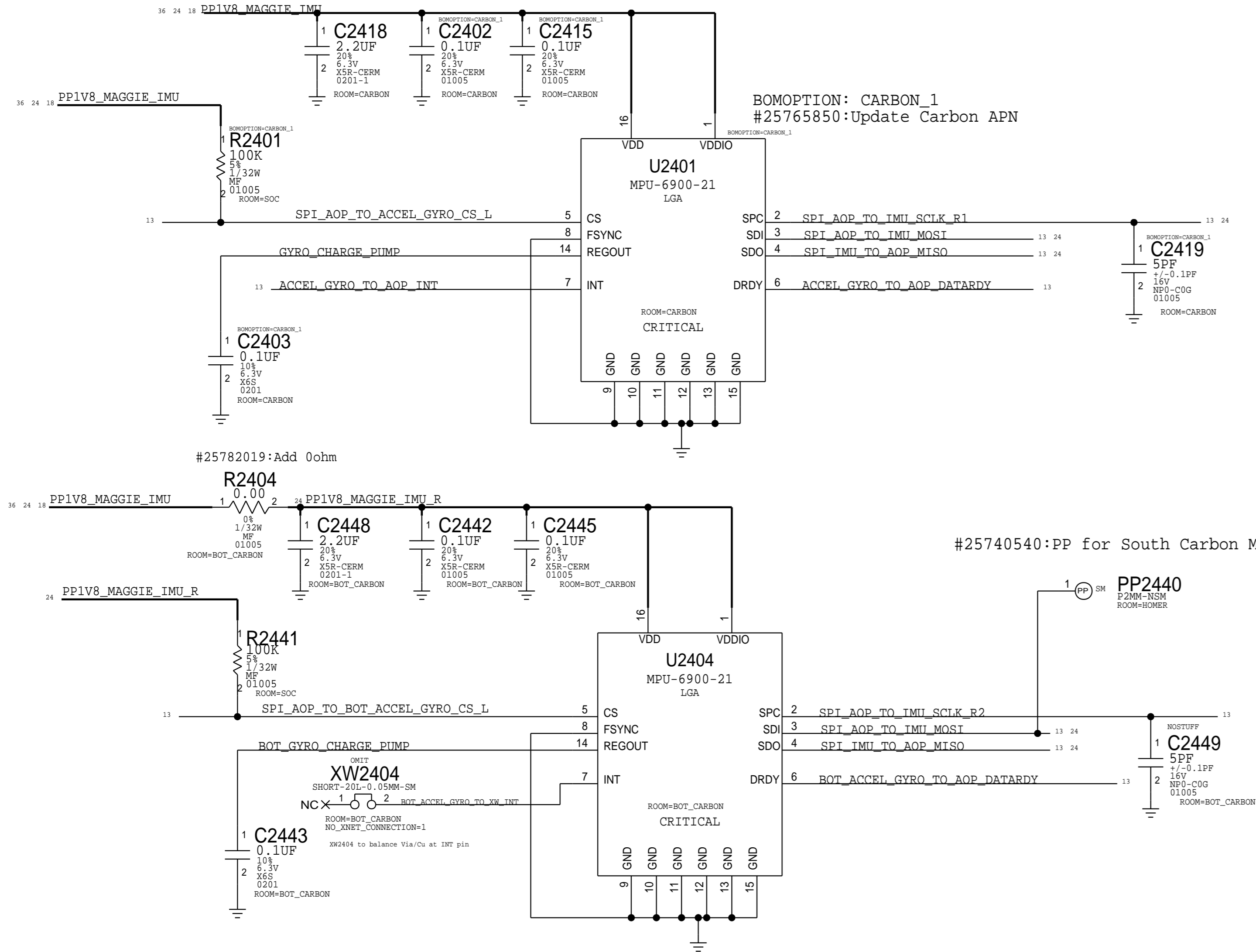

MAGNESIUM - COMPASS

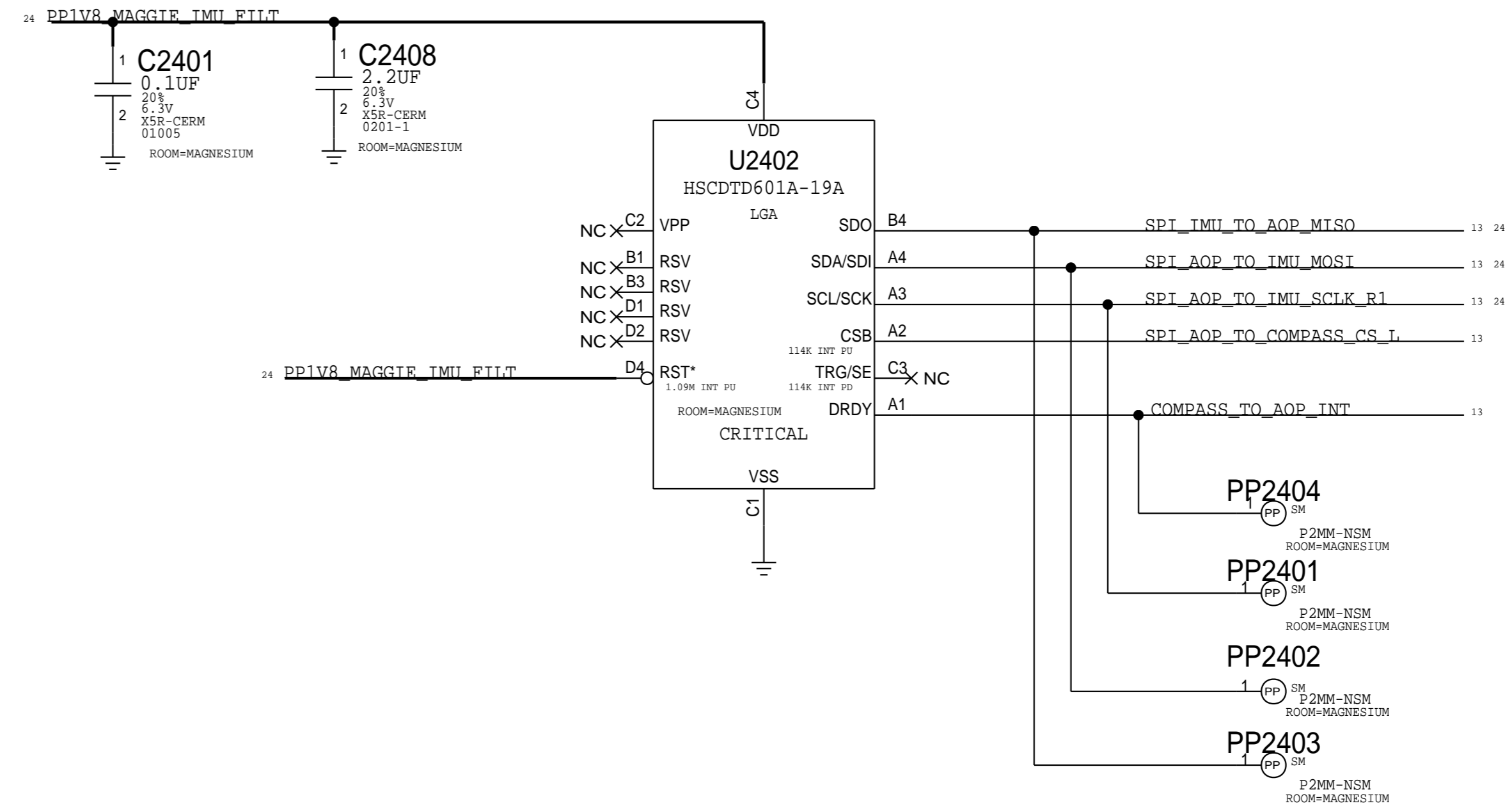

PHOSPHORUS

#24593845

BOSCH (APN:338S00188): nostuff C2420/C2421/C2422/C2423 and R2403 PU
 ST (APN:338S00230): stuff C2420-C2423, C2420R2422 with 155S00017, stuff R2403 PU
 C2420=4pF(131S0253), C2405=3pF(131S0251) per #25691124

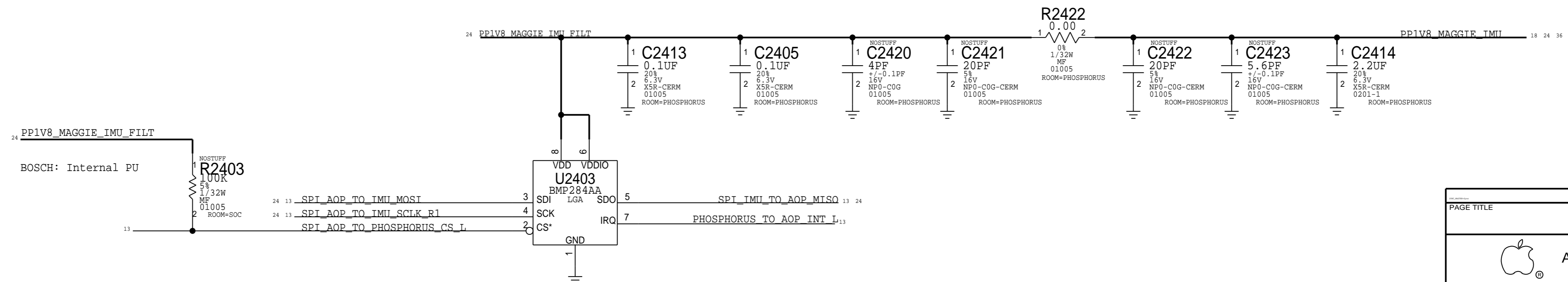

PAGE TITLE		SENSORS	
	DRAWING NUMBER	051-00482	SIZE
	REVISION	8.0.0	D
NOTICE OF PROPRIETARY PROPERTY: THE INFORMATION CONTAINED HEREIN IS THE PROPRIETARY PROPERTY OF APPLE INC. THE POSSESSOR AGREES TO THE FOLLOWING: I TO MAINTAIN THIS DOCUMENT IN CONFIDENCE II NOT TO REPRODUCE OR COPY IT III NOT TO REVEAL OR PUBLISH IT IN WHOLE OR PART IV ALL RIGHTS RESERVED		BRANCH	
		PAGE	24 OF 53
		SHEET	24 OF 81

UTAH POWER

NOTE: OUTPUT IMPEDANCE MUST BE >0.005-OHM
 IN ORDER TO MEET CAP ESR REQUIREMENT PER LDO SPEC.
 VENDOR ALSO RECOMMENDS CIN = COUT FOR STABILITY

Scrub voltage selection

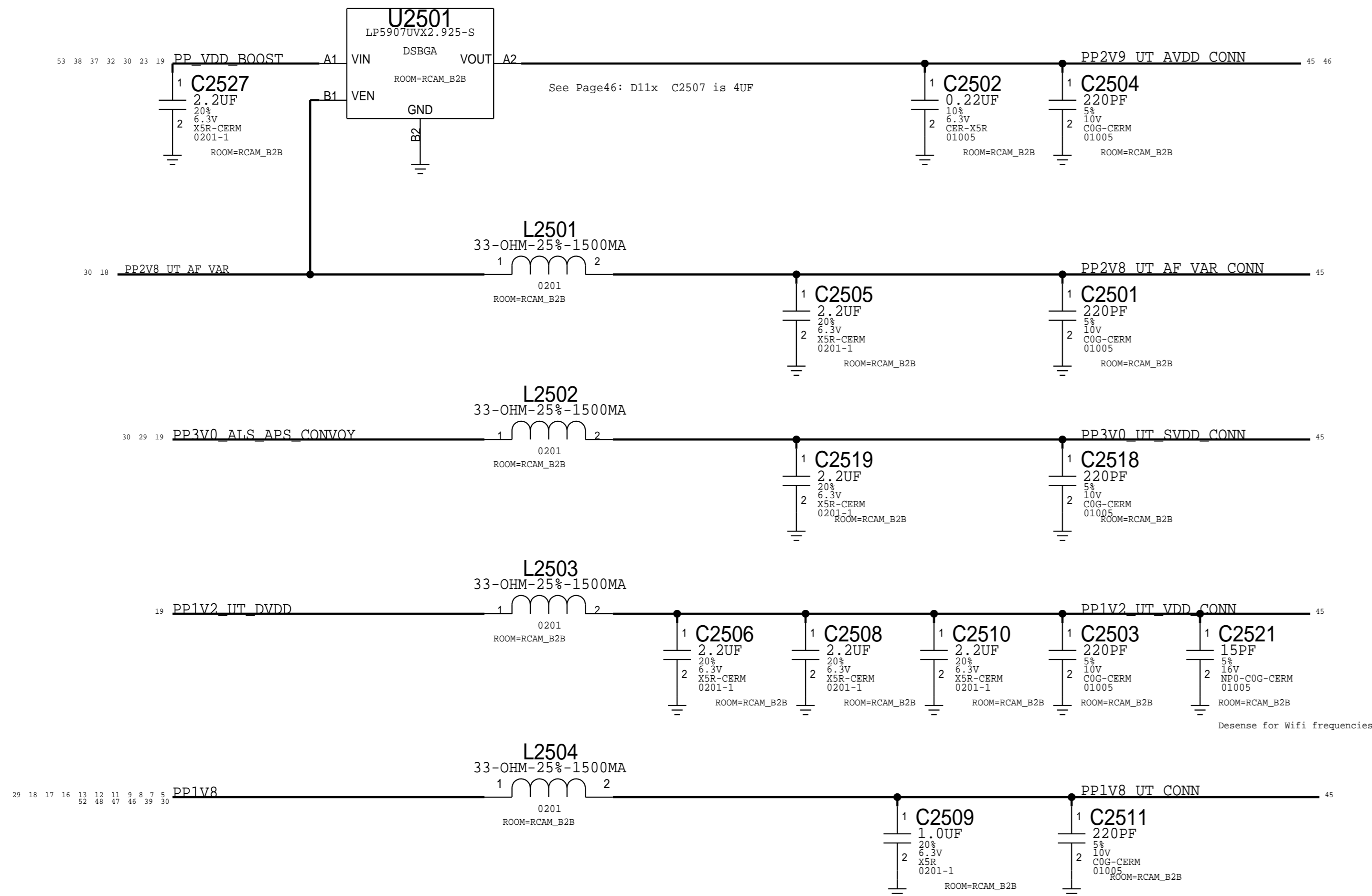

IO FILTERS

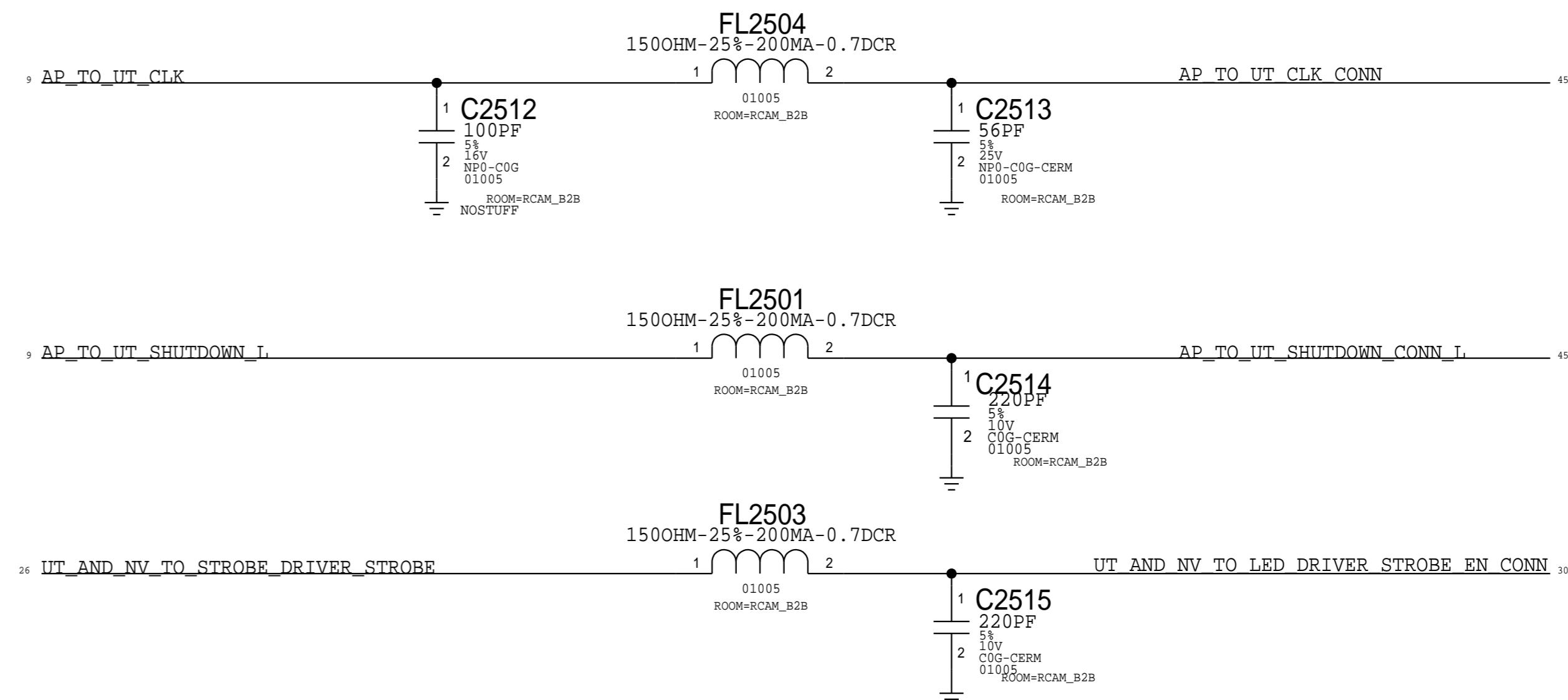

LPDP FILTERS

AC return path for LPDP which is referenced to GND and VDD_MAIN

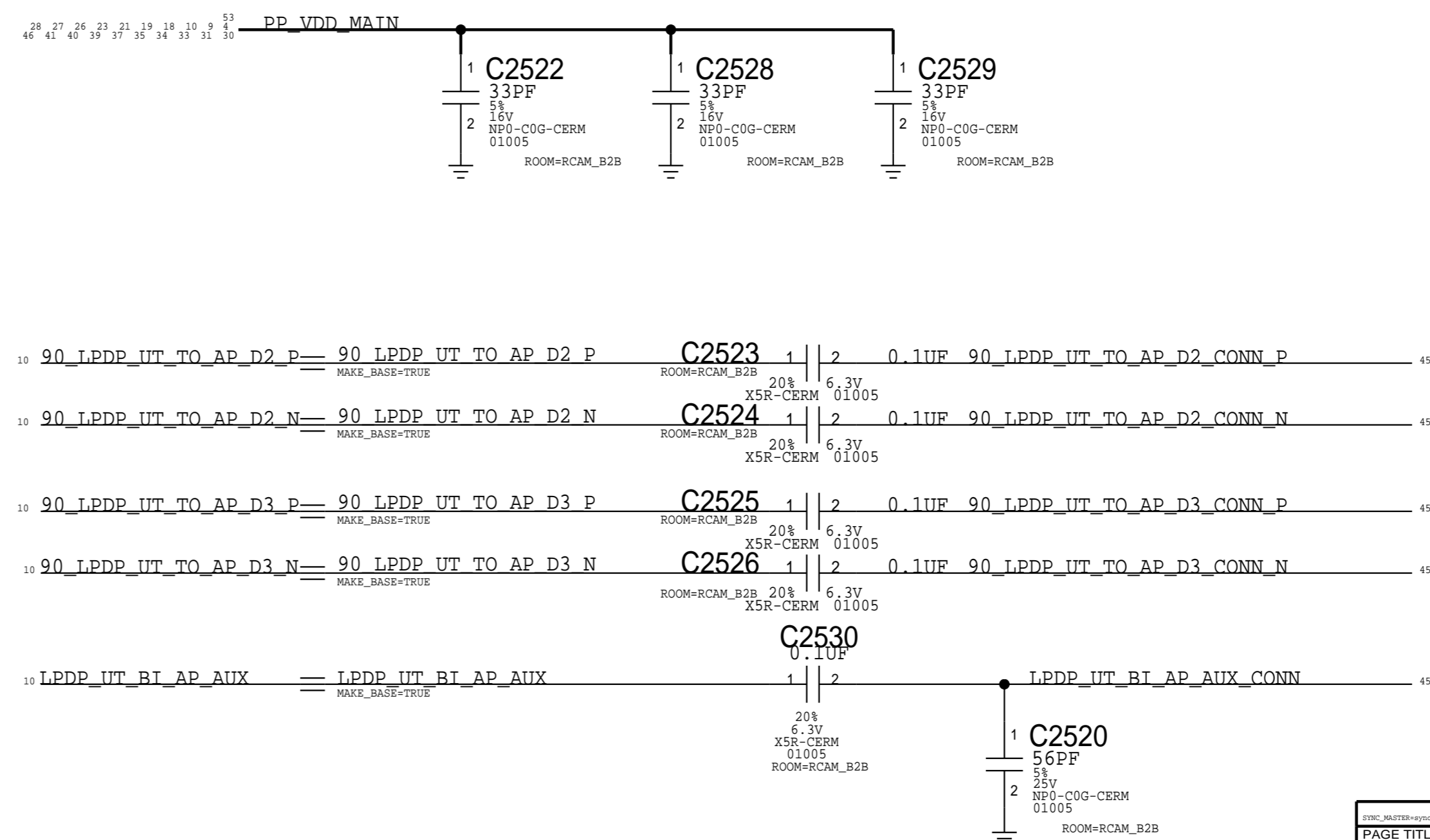

PAGE TITLE		B2B FILTERS: UTAH	
Apple Inc.	DRAWING NUMBER	051-00482	SIZE
	REVISION	8.0.0	D
NOTICE OF PROPRIETARY PROPERTY: THE INFORMATION CONTAINED HEREIN IS THE PROPRIETARY PROPERTY OF APPLE INC. THE POSSESSOR AGREES TO THE FOLLOWING: I TO MAINTAIN THIS DOCUMENT IN CONFIDENCE II NOT TO REPRODUCE OR COPY IT III NOT TO REVEAL OR PUBLISH IT IN WHOLE OR PART IV ALL RIGHTS RESERVED		BRANCH	
		PAGE	25 OF 53
		SHEET	25 OF 81

STROBE DRIVERS INSIDE NEO SIP MODULE

D10/sip_neo

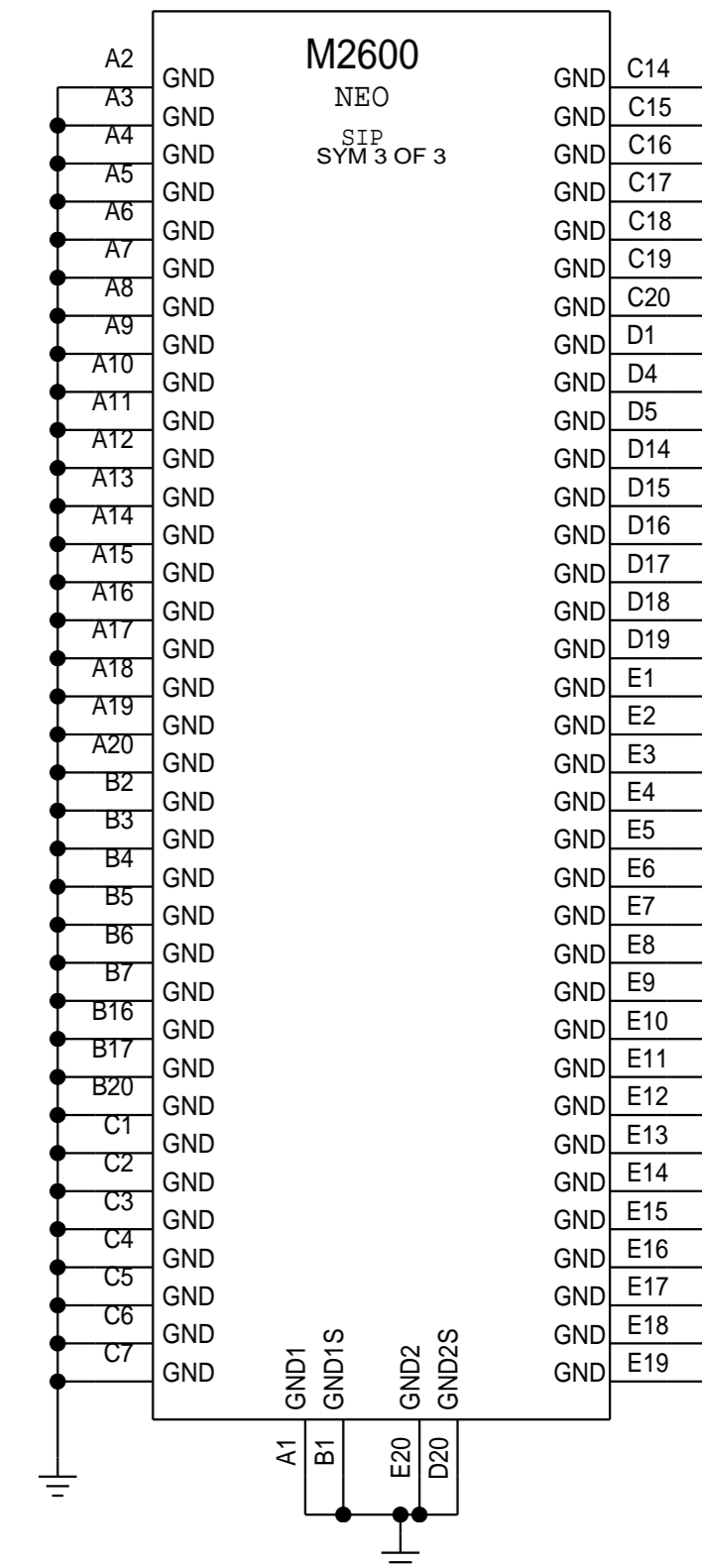
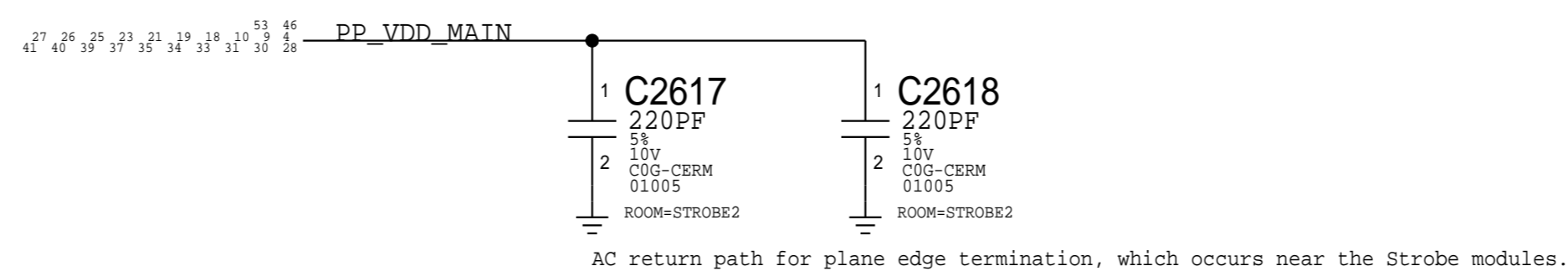
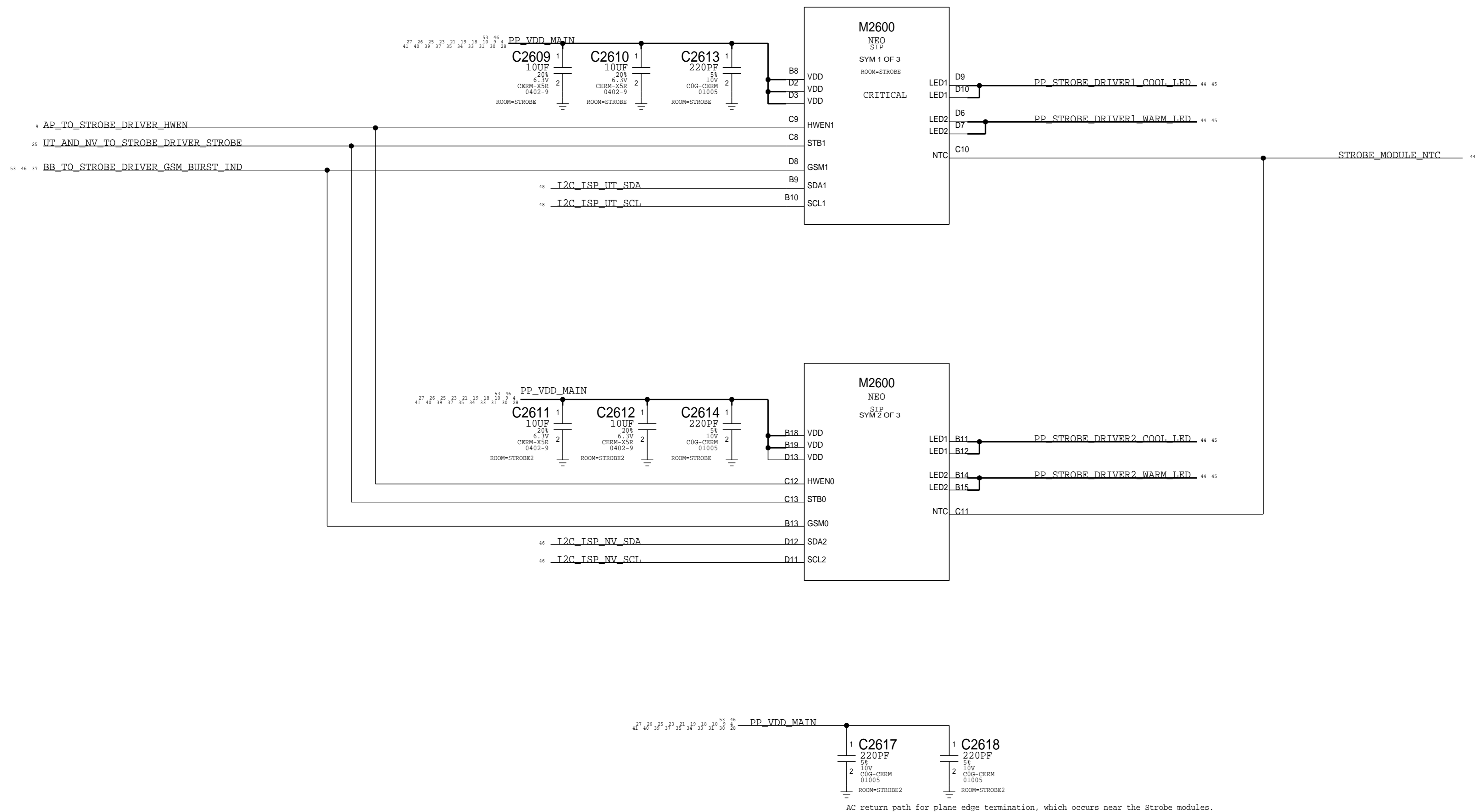

051_l18-apple

PAGE TITLE		
CAMERA : STROBE DRIVER		
	DRAWING NUMBER	051-00482
	REVISION	8.0.0
NOTICE OF PROPRIETARY PROPERTY:		
<small>THE INFORMATION CONTAINED HEREIN IS THE PROPRIETARY PROPERTY OF APPLE INC. THE POSSESSOR AGREES TO THE FOLLOWING: I TO MAINTAIN THIS DOCUMENT IN CONFIDENCE II NOT TO REPRODUCE OR COPY IT III NOT TO REVEAL OR PUBLISH IT IN WHOLE OR PART IV ALL RIGHTS RESERVED</small>		
BRANCH		
PAGE	26 OF 53	
SHEET	26 OF 81	

ACCESSORY BUCK

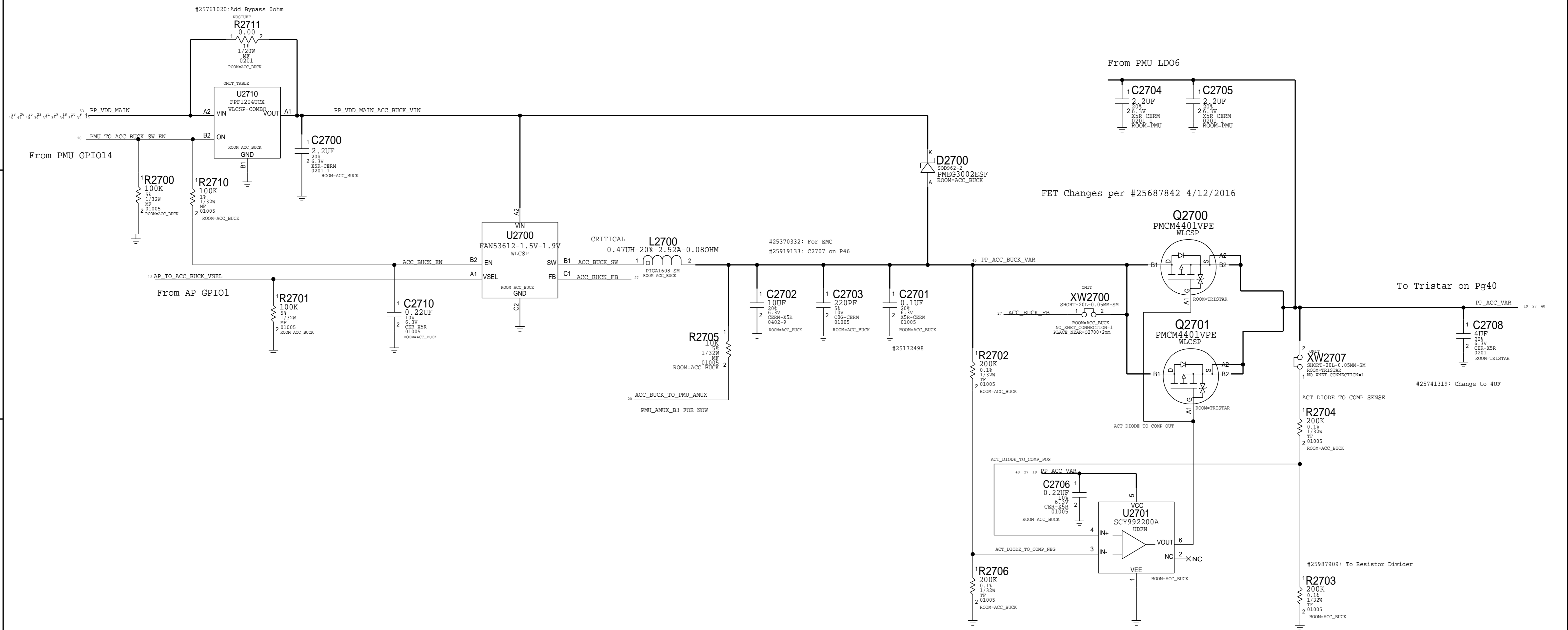

Apple Inc.		DRAWING NUMBER 051-00482	SIZE D
REVISION 8.0.0		BRANCH	
PAGE 27 OF 53		SHEET 27 OF 81	
NOTICE OF PROPRIETARY PROPERTY: THE INFORMATION CONTAINED HEREIN IS THE PROPRIETARY PROPERTY OF APPLE INC. THE POSSESSOR AGREES TO THE FOLLOWING: I TO MAINTAIN THIS DOCUMENT IN CONFIDENCE II NOT TO REPRODUCE OR COPY IT III NOT TO REVEAL OR PUBLISH IT IN WHOLE OR PART IV ALL RIGHTS RESERVED			

8

7

6

5

4

3

2

1

D

D

C

C

B

B

A

A

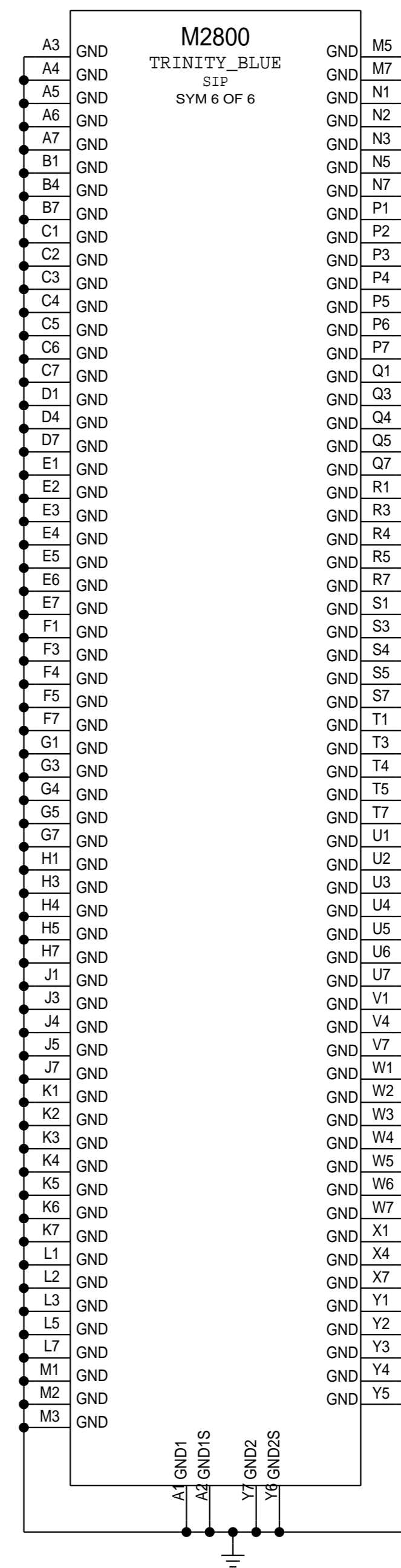
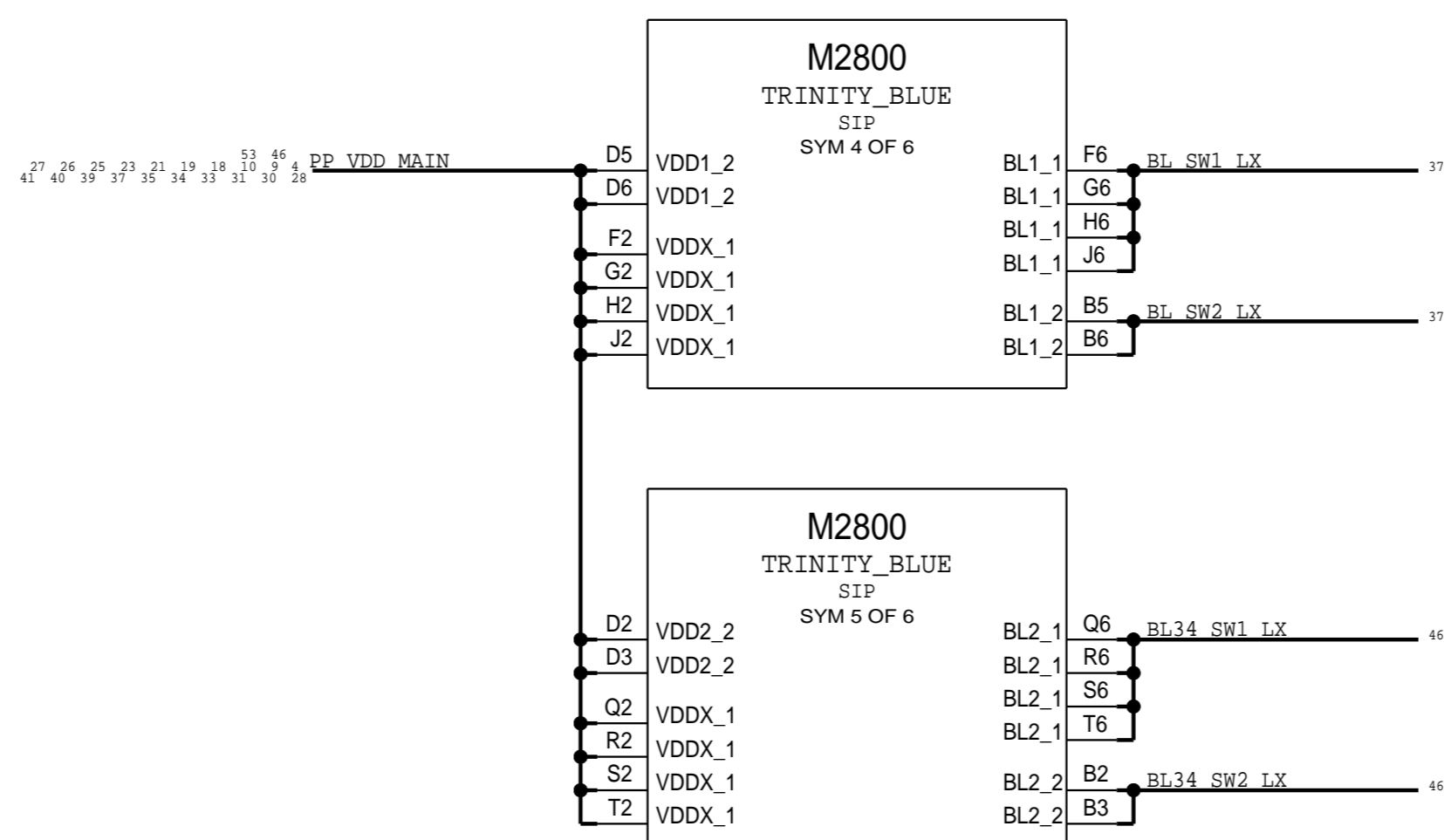
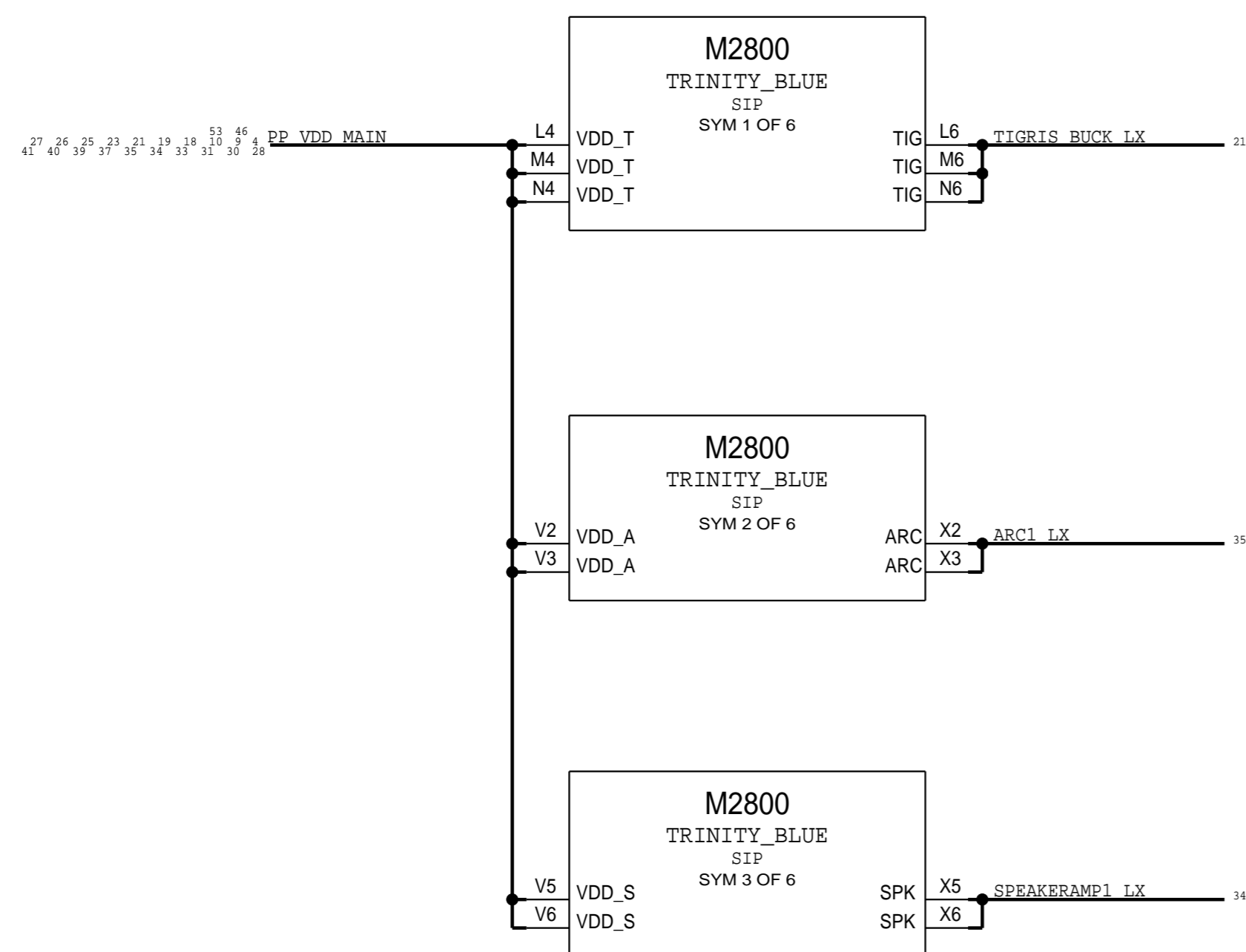

PAGE TITLE		TRINITY:FF SPECIFIC	
	DRAWING NUMBER	051-00482	SIZE
	REVISION	8.0.0	D
NOTICE OF PROPRIETARY PROPERTY: THE INFORMATION CONTAINED HEREIN IS THE PROPRIETARY PROPERTY OF APPLE INC. THE POSSESSOR AGREES TO THE FOLLOWING: I TO MAINTAIN THIS DOCUMENT IN CONFIDENCE II NOT TO REPRODUCE OR COPY IT III NOT TO REVEAL OR PUBLISH IT IN WHOLE OR PART IV ALL RIGHTS RESERVED		BRANCH	
		PAGE	28 OF 53
		SHEET	28 OF 81

8

7

6

5

4

3

2

1

NEW HAMPSHIRE POWER

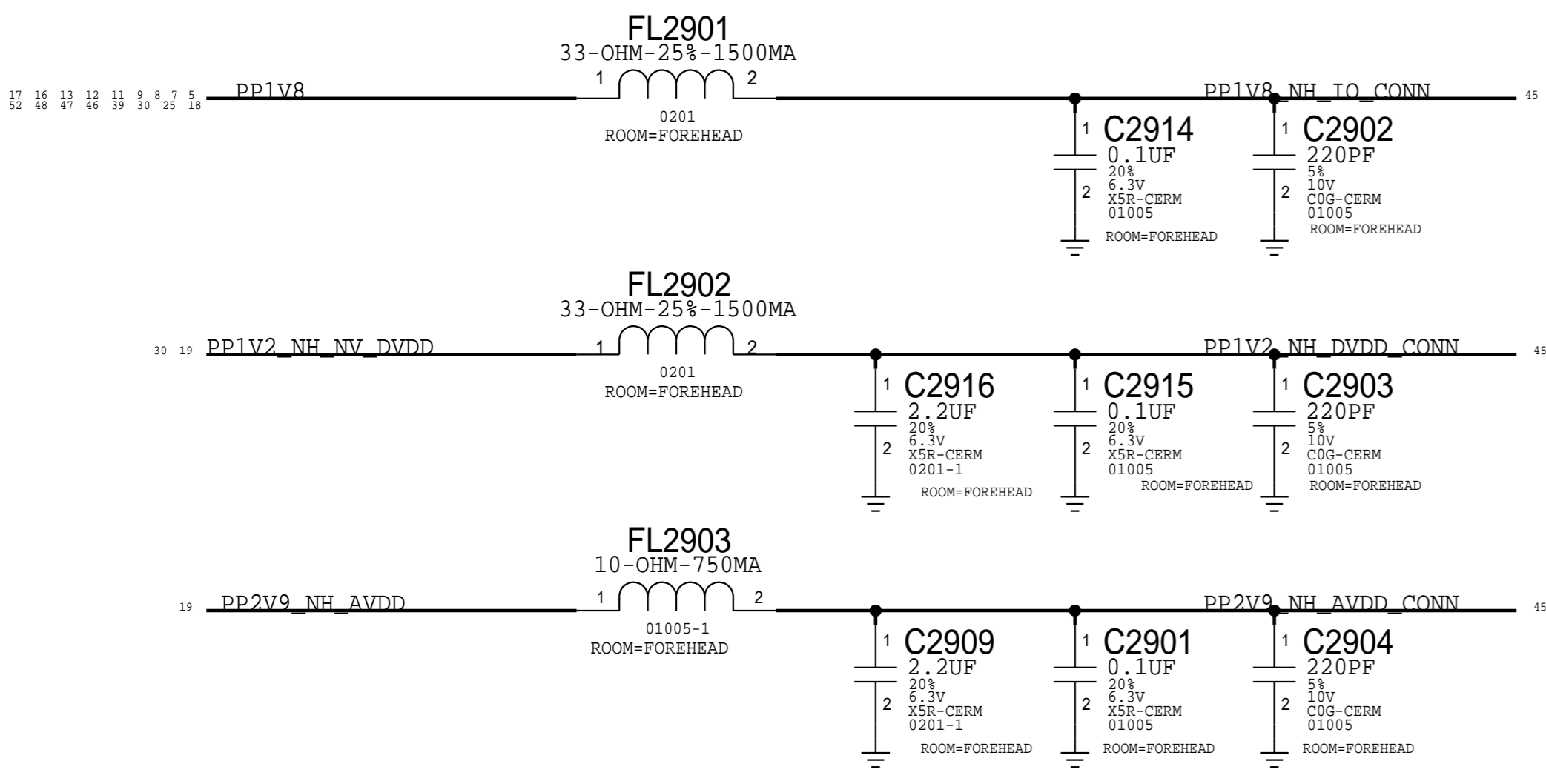

PROX, ALS, & CONVOY POWER

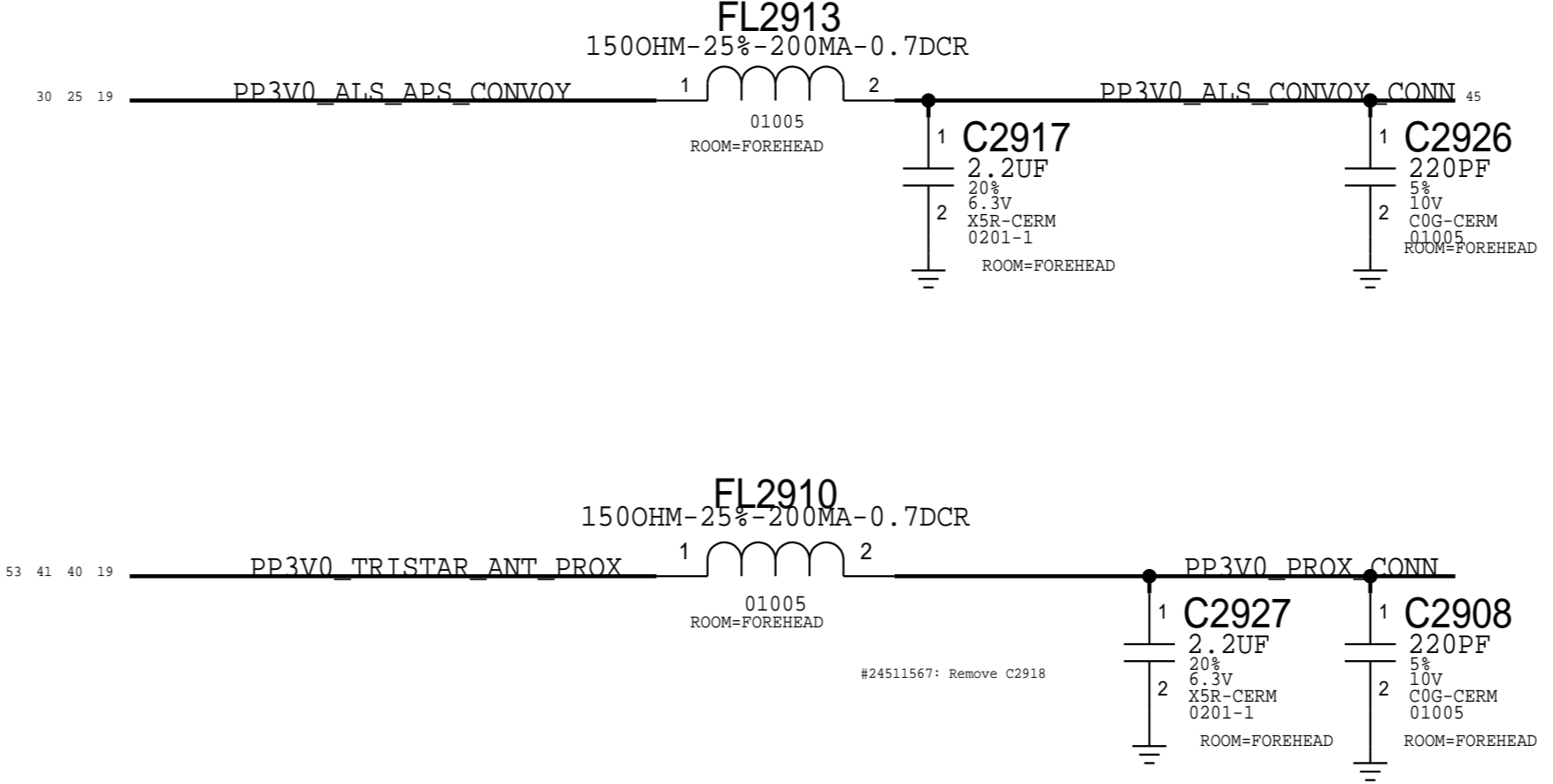

NEW HAMPSHIRE I/O

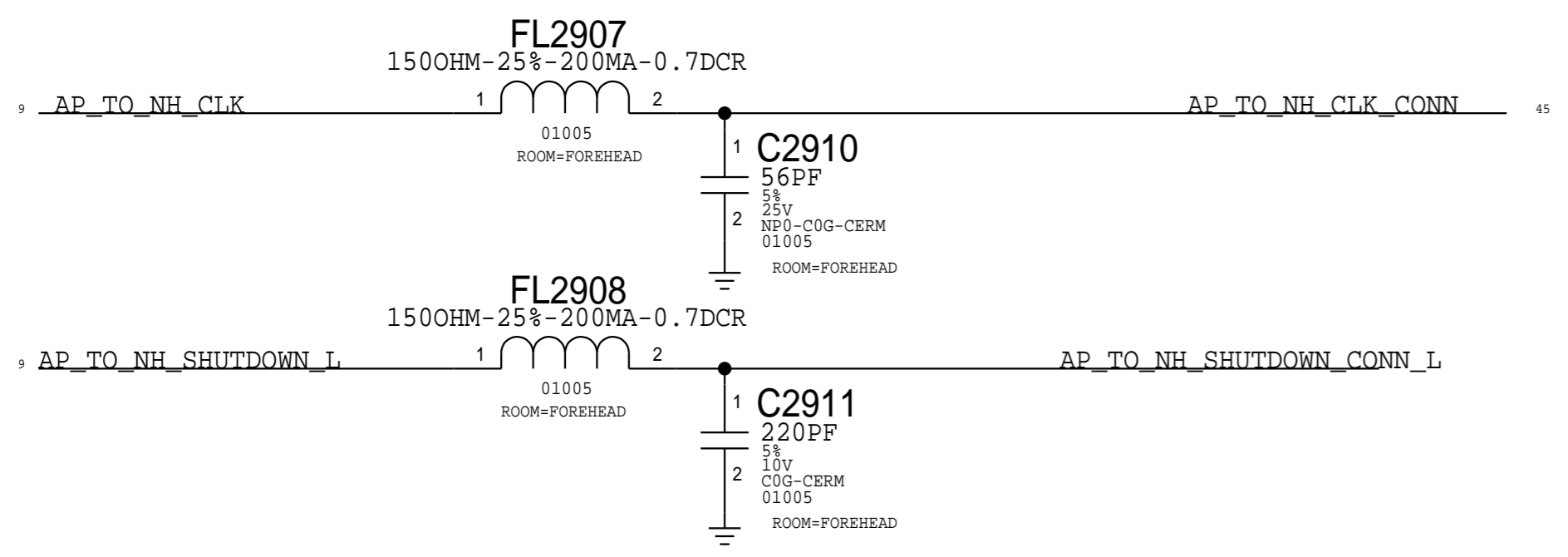

CONVOY I/O

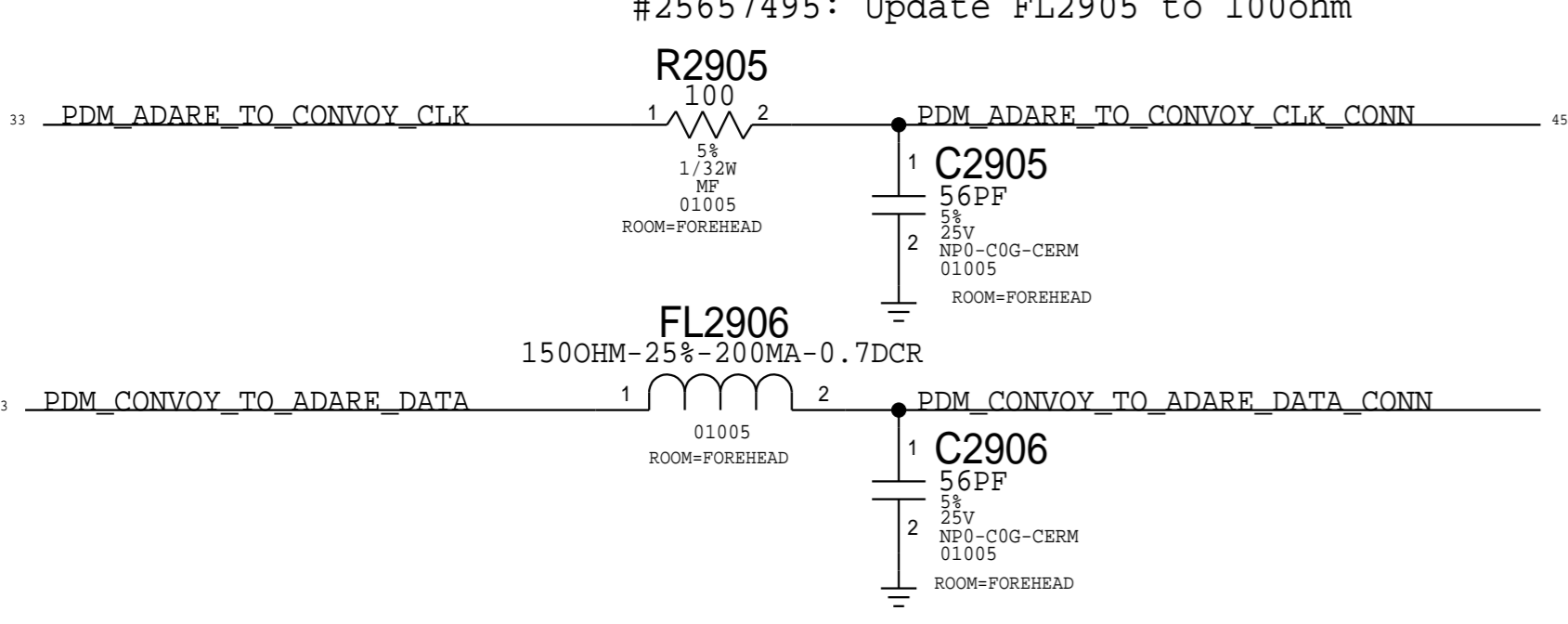

PROX/ALS I/O

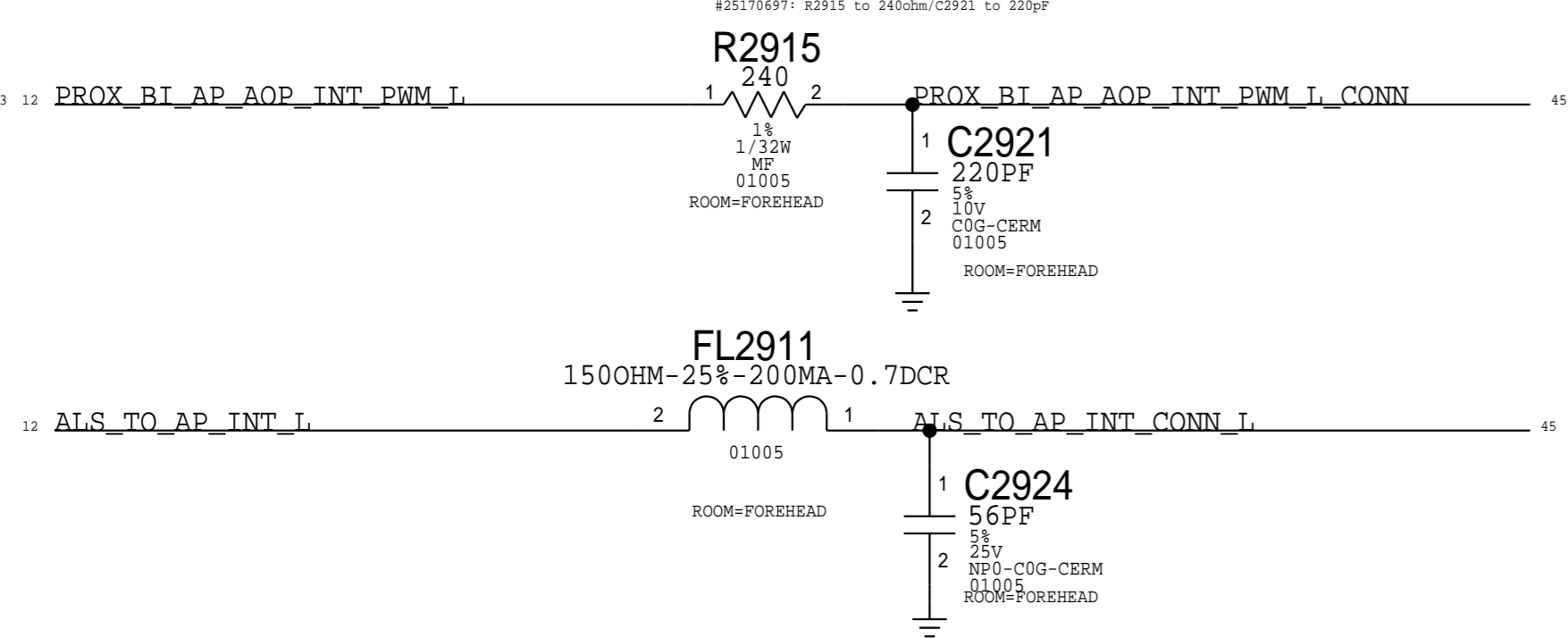

SPEAKER2

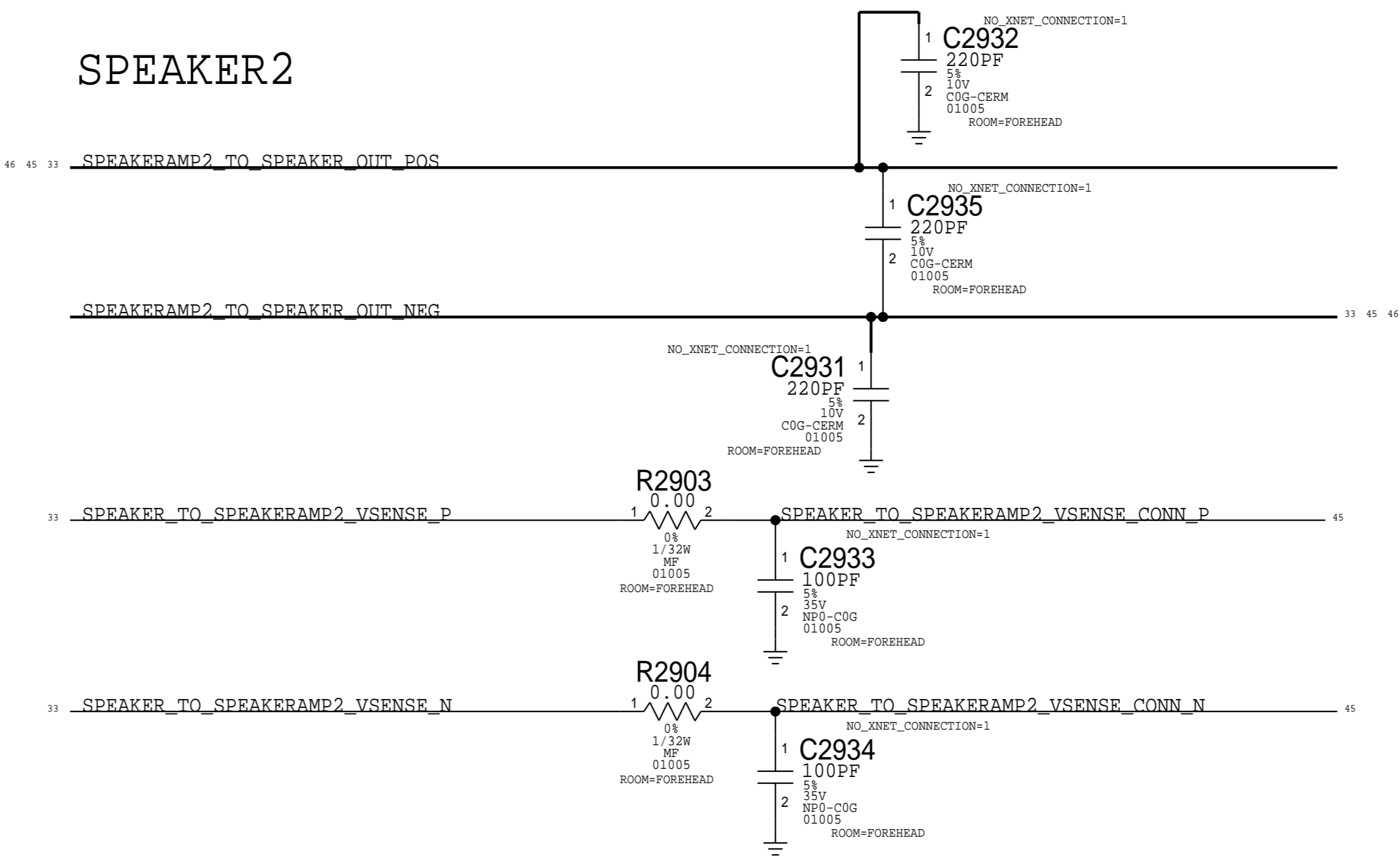

MIC3

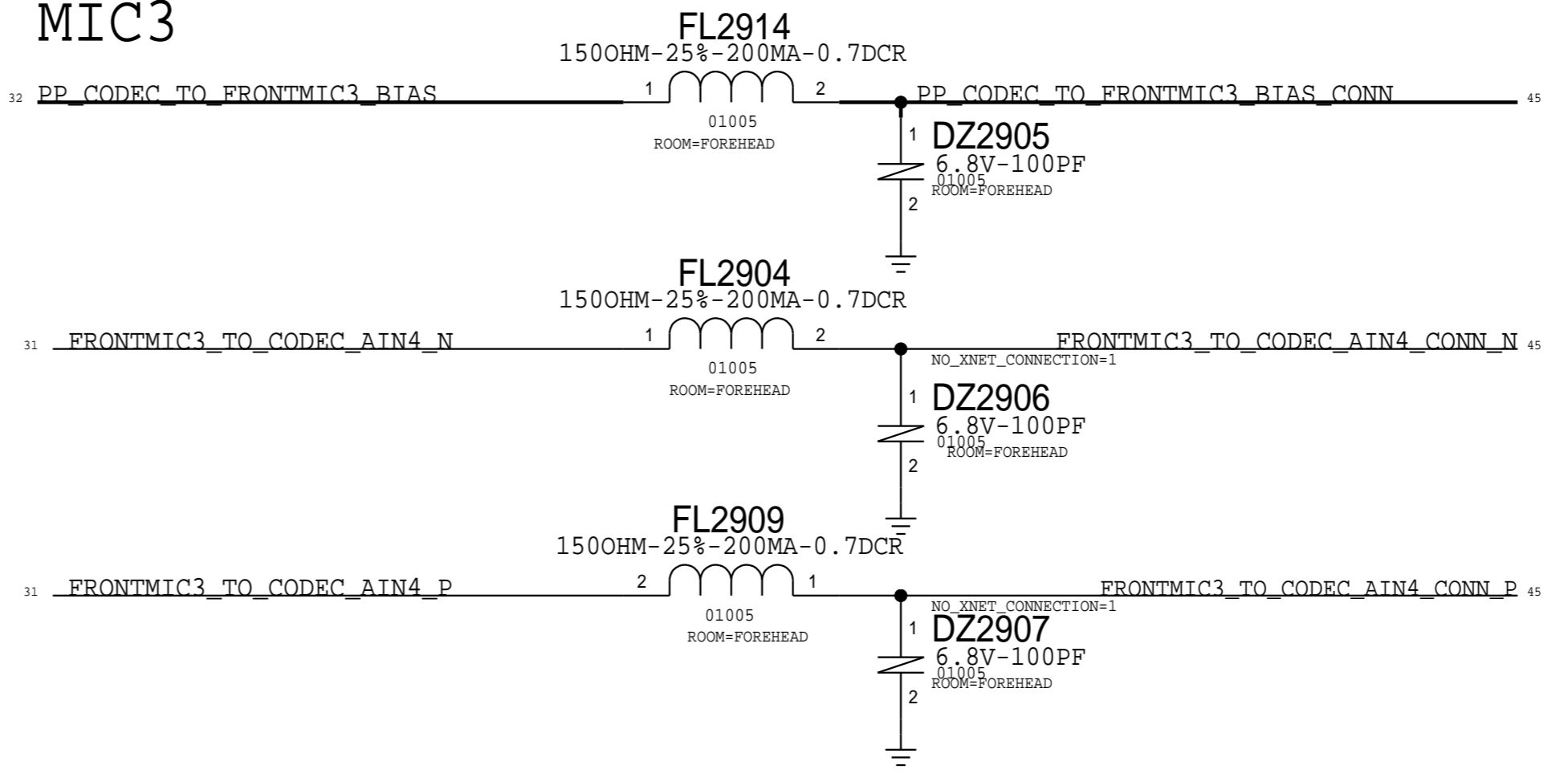

PAGE TITLE			B2B: FOREHEAD		
Apple Inc.		DRAWING NUMBER	051-00482	SIZE	D
		REVISION	8.0.0		
NOTICE OF PROPRIETARY PROPERTY:		BRANCH			
THE INFORMATION CONTAINED HEREIN IS THE PROPRIETARY PROPERTY OF APPLE INC. THE POSSESSOR AGREES TO THE FOLLOWING:		PAGE	29 OF 53		
I TO MAINTAIN THIS DOCUMENT IN CONFIDENCE		SHEET	29 OF 81		
II NOT TO REPRODUCE OR COPY IT					
III NOT TO REVEAL OR PUBLISH IT IN WHOLE OR PART					
IV ALL RIGHTS RESERVED					

NEVADA POWER
 NOTE: OUTPUT IMPEDANCE MUST BE >0.005-OHM
 IN ORDER TO MEET CAP ESR REQUIREMENT PER LDO SPEC.
 VENDOR ALSO RECOMMENDS CIN = COUT FOR STABILITY

NEVADA CONNECTOR

THIS ONE ---> 516S00152 RCPT (USED ON MLB)
 516S00151 PLUG

THIS PAGE UNIQUE TO LARGE FORM FACTOR
 OTHER FORM FACTOR SPECIFIC PAGES:
 4 - Mechanical
 46 - FF Specific

D

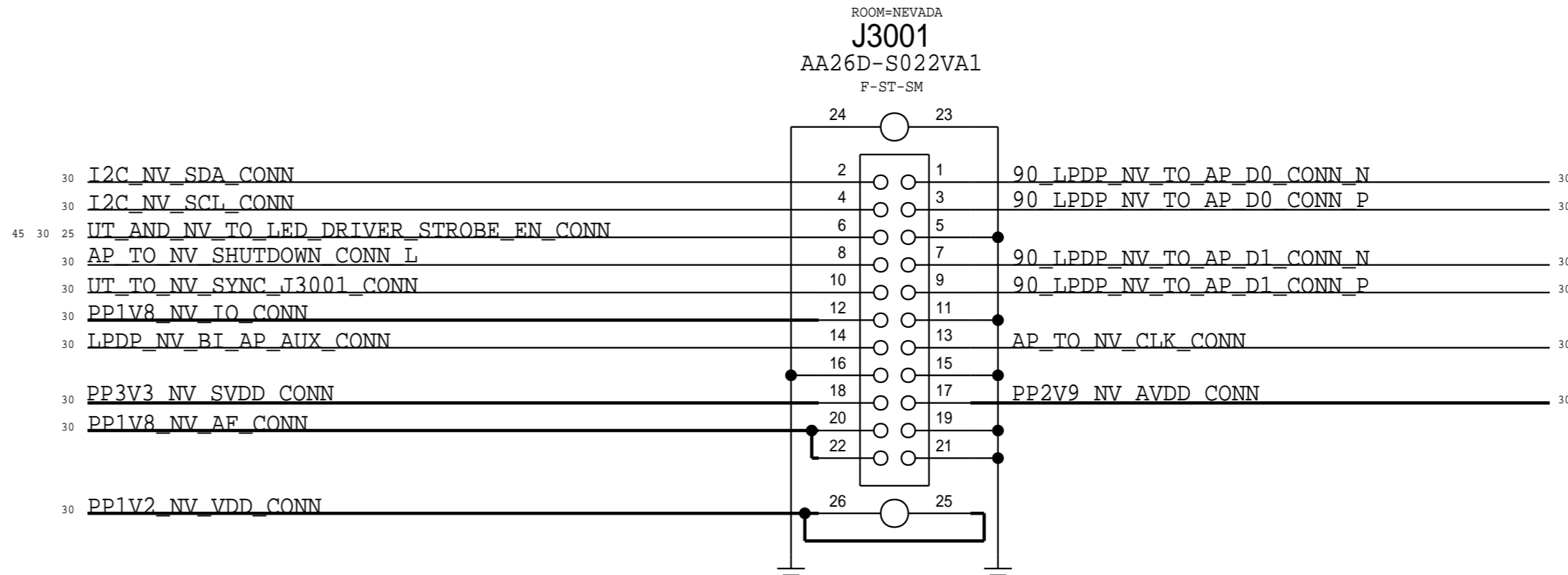
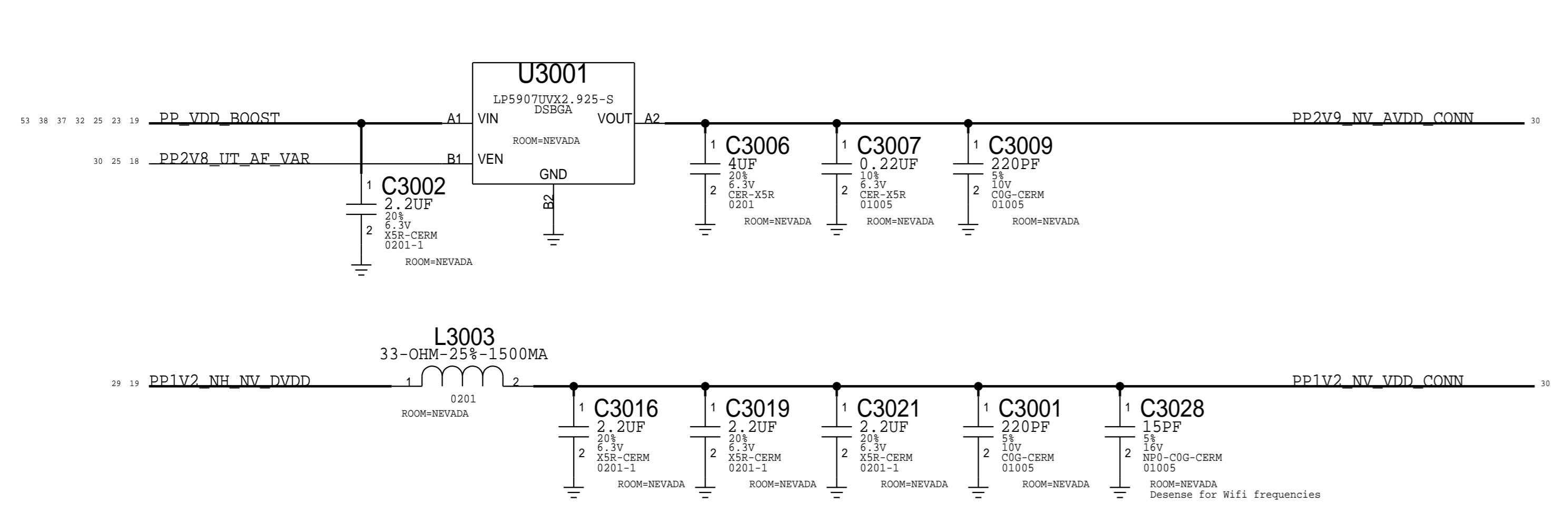

C

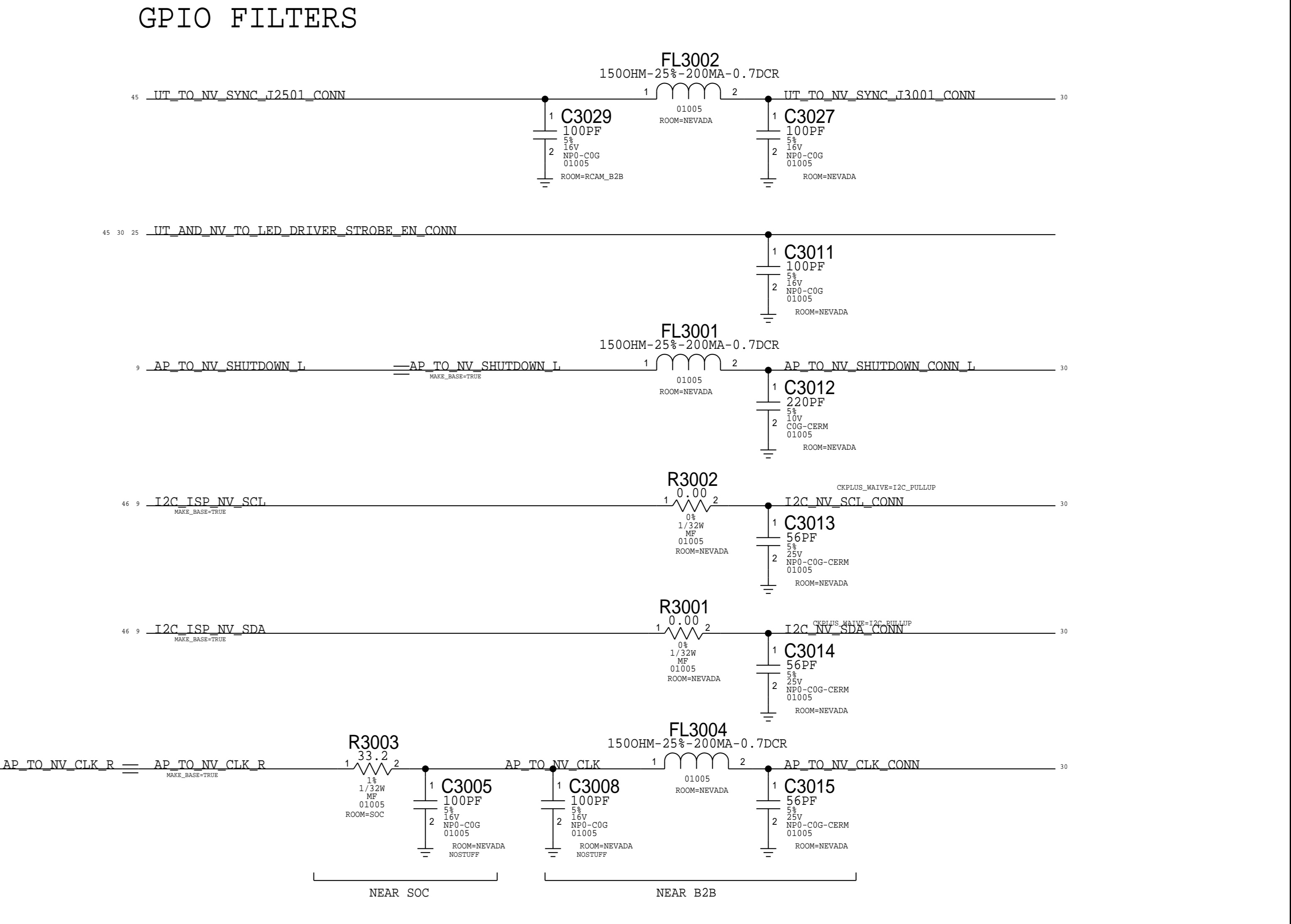
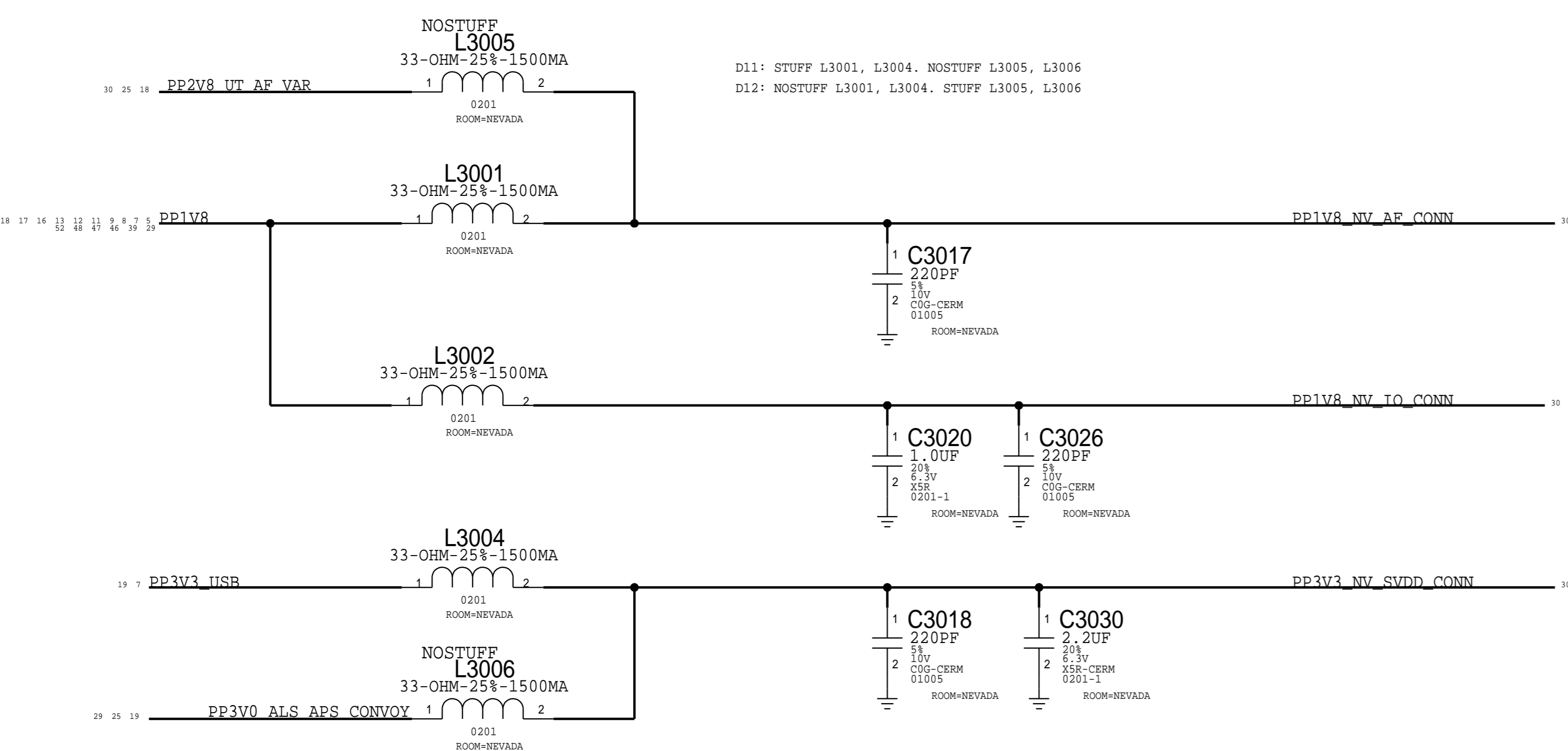

B

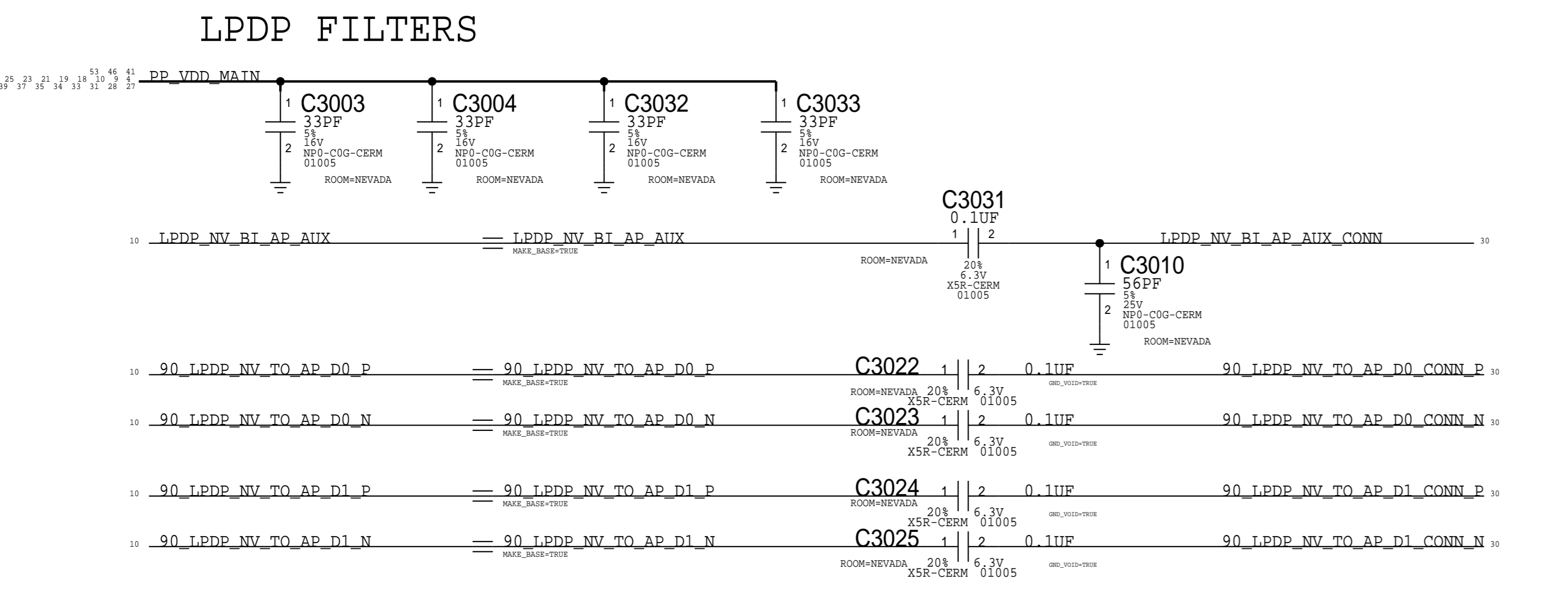

A

PAGE TITLE		B2B:NEVADA	
Apple Inc.		DRAWING NUMBER	051-00482
		REVISION	8.0.0
NOTICE OF PROPRIETARY PROPERTY: THE INFORMATION CONTAINED HEREIN IS THE PROPRIETARY PROPERTY OF APPLE INC. THE POSSESSOR AGREES TO THE FOLLOWING: I TO MAINTAIN THIS DOCUMENT IN CONFIDENCE II NOT TO REPRODUCE OR COPY IT III NOT TO REVEAL OR PUBLISH IT IN WHOLE OR PART IV ALL RIGHTS RESERVED		BRANCH	
		PAGE	30 OF 53
		SHEET	30 OF 81

CALTRA AUDIO CODEC (ANALOG INPUTS & OUTPUTS)

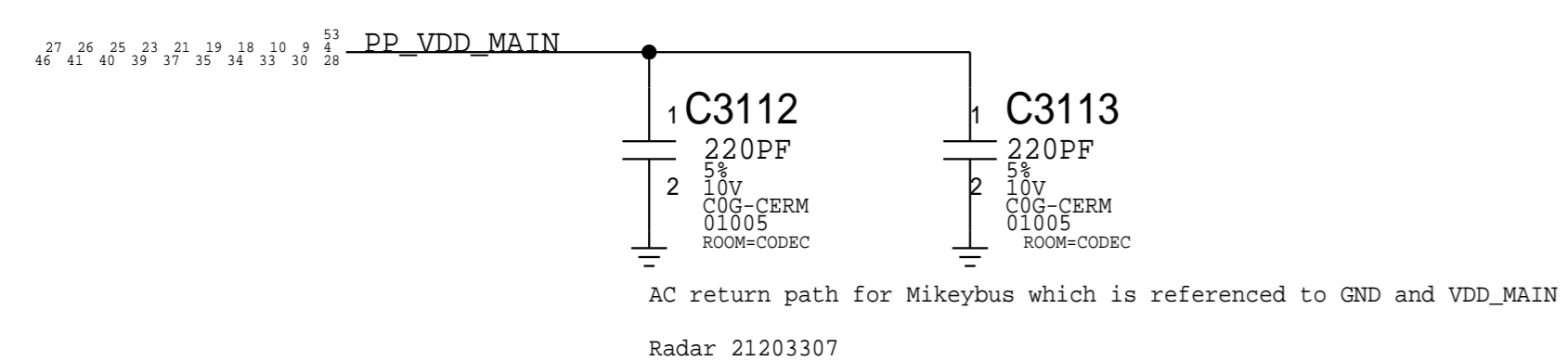
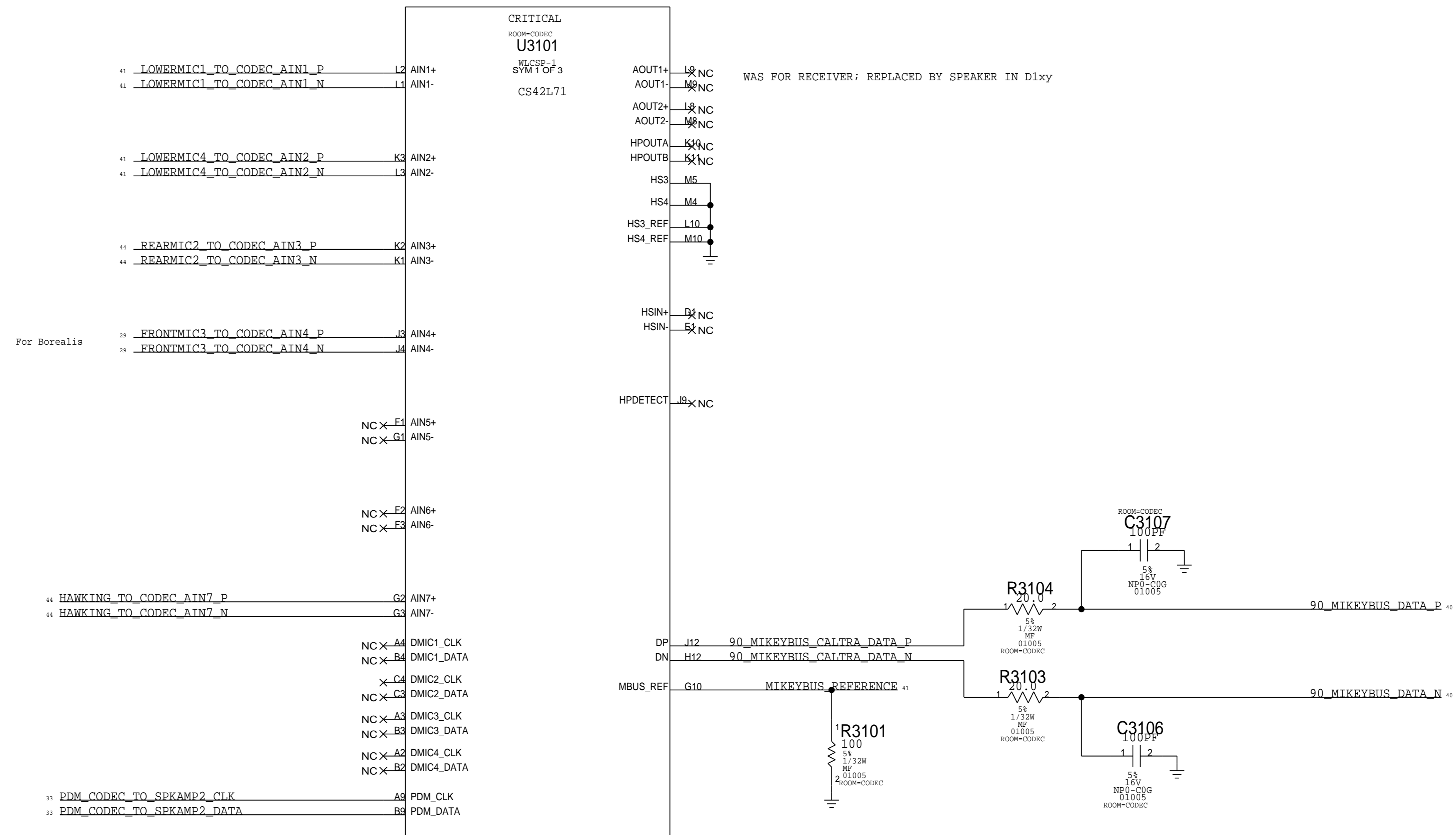

PAGE TITLE AUDIO:CALTRA CODEC (1/2)		
	DRAWING NUMBER 051-00482	SIZE D
	REVISION 8.0.0	
NOTICE OF PROPRIETARY PROPERTY: THE INFORMATION CONTAINED HEREIN IS THE PROPRIETARY PROPERTY OF APPLE INC. THE POSSESSOR AGREES TO THE FOLLOWING: I TO MAINTAIN THIS DOCUMENT IN CONFIDENCE II NOT TO REPRODUCE OR COPY IT III NOT TO REVEAL OR PUBLISH IT IN WHOLE OR PART IV ALL RIGHTS RESERVED		
BRANCH	PAGE 31 OF 53	
SHEET	31 OF 81	

CALTRA AUDIO CODEC (POWER & I/O)

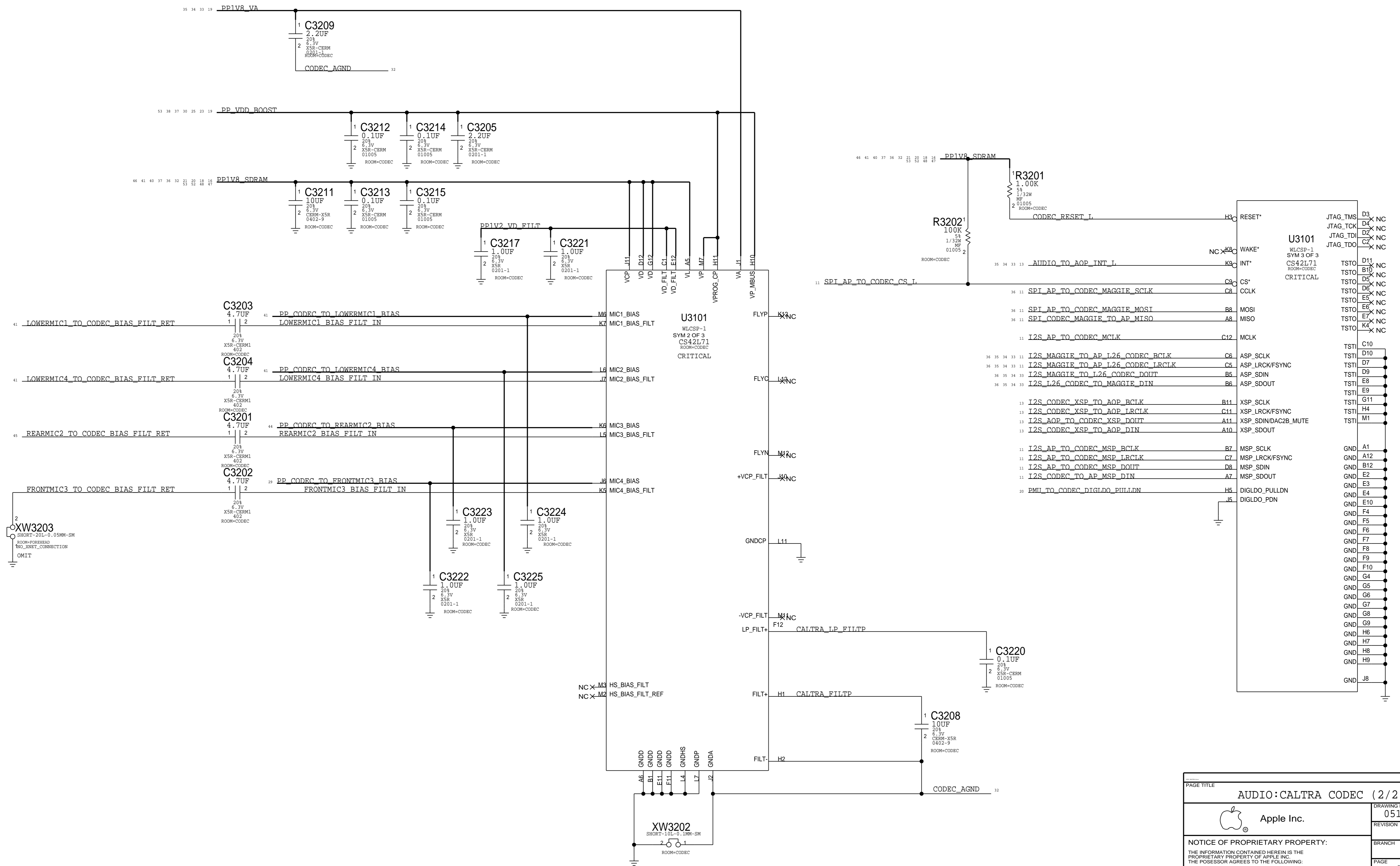

PAGE TITLE		
AUDIO: CALTRA CODEC (2/2)		
Apple Inc.	DRAWING NUMBER	051-00482
	REVISION	8.0.0
NOTICE OF PROPRIETARY PROPERTY: THE INFORMATION CONTAINED HEREIN IS THE PROPRIETARY PROPERTY OF APPLE INC. THE POSSESSOR AGREES TO THE FOLLOWING: I TO MAINTAIN THIS DOCUMENT IN CONFIDENCE II NOT TO REPRODUCE OR COPY IT III NOT TO REVEAL OR PUBLISH IT IN WHOLE OR PART IV ALL RIGHTS RESERVED	BRANCH	
	PAGE	32 OF 53
	SHEET	32 OF 81

SPEAKER AMPLIFIER 2 (North)

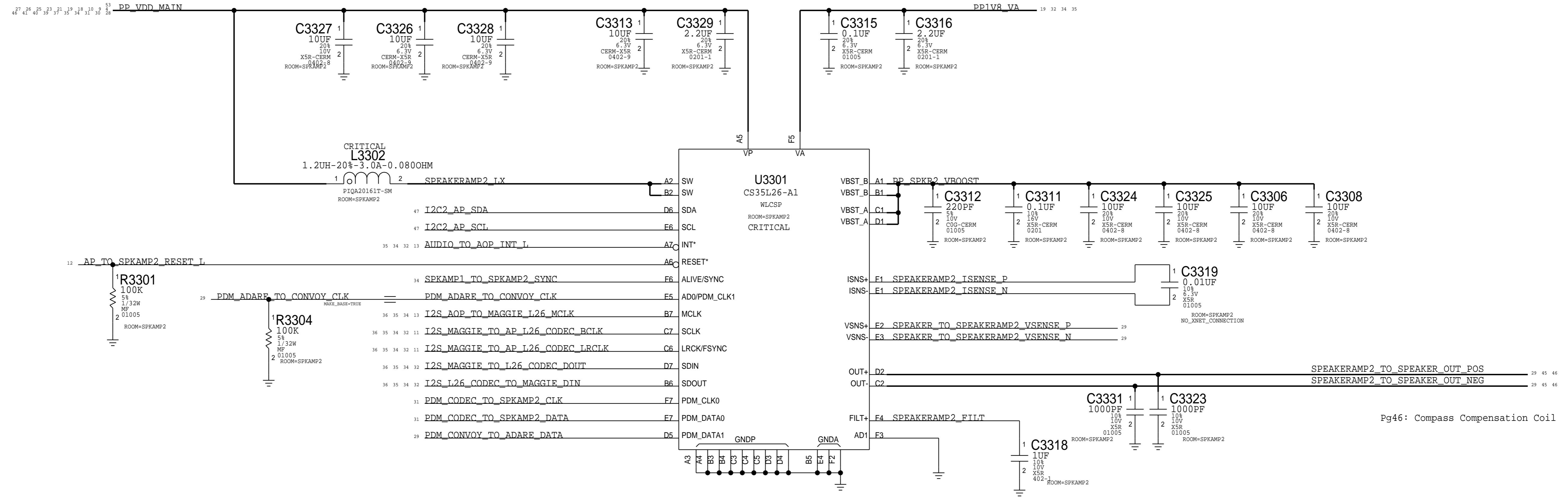

SPEAKER AMPLIFIER 1 (South)

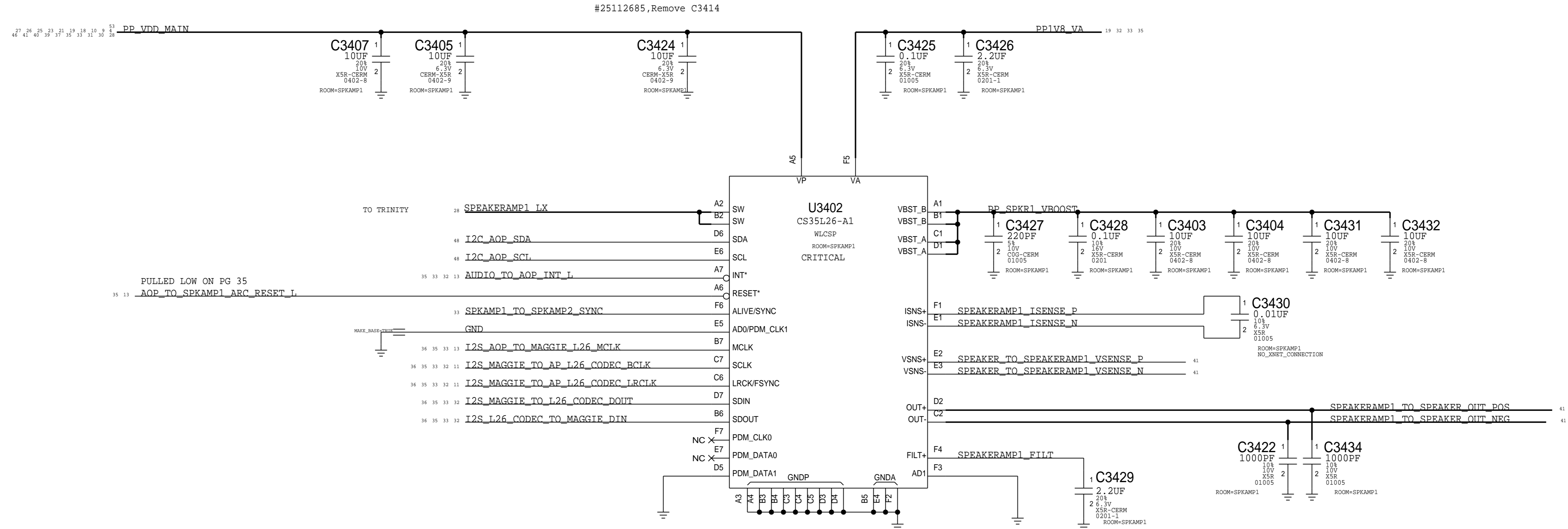

PAGE TITLE AUDIO: SPEAKER AMP 1		
Apple Inc.	DRAWING NUMBER 051-00482	SIZE D
REVISION 8.0.0		
BRANCH		
PAGE 34 OF 53		
SHEET 34 OF 81		

NOTICE OF PROPRIETARY PROPERTY:
THE INFORMATION CONTAINED HEREIN IS THE PROPRIETARY PROPERTY OF APPLE INC. THE POSSESSOR AGREES TO THE FOLLOWING:
I TO MAINTAIN THIS DOCUMENT IN CONFIDENCE
II NOT TO REPRODUCE OR COPY IT
III NOT TO REVEAL OR PUBLISH IT IN WHOLE OR PART
IV ALL RIGHTS RESERVED

ARC DRIVER

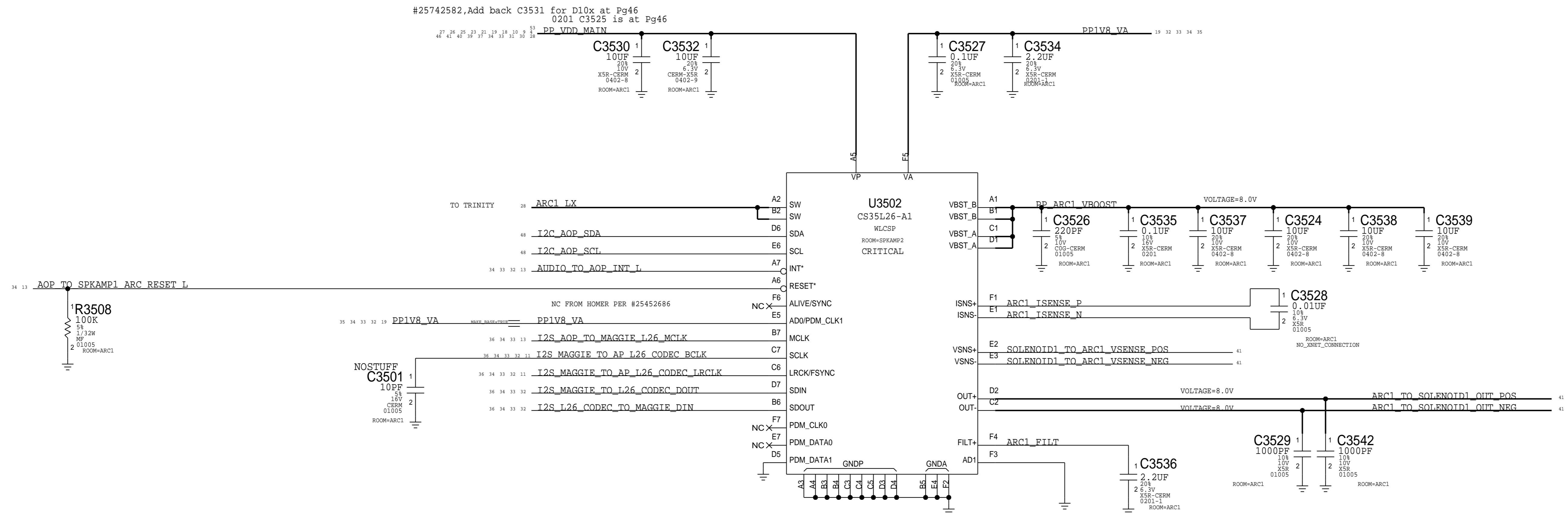

PAGE TITLE			ARC:DRIVER		
Apple Inc.		DRAWING NUMBER	051-00482	SIZE	D
		REVISION	8.0.0		
NOTICE OF PROPRIETARY PROPERTY:		BRANCH			
THE INFORMATION CONTAINED HEREIN IS THE PROPRIETARY PROPERTY OF APPLE INC. THE POSSESSOR AGREES TO THE FOLLOWING:		PAGE	35 OF 53		
I TO MAINTAIN THIS DOCUMENT IN CONFIDENCE		SHEET	35 OF 81		
II NOT TO REPRODUCE OR COPY IT					
III NOT TO REVEAL OR PUBLISH IT IN WHOLE OR PART					
IV ALL RIGHTS RESERVED					

D

C

B

A

D

C

B

A

MAGGIE LDO

APN: 353S00842

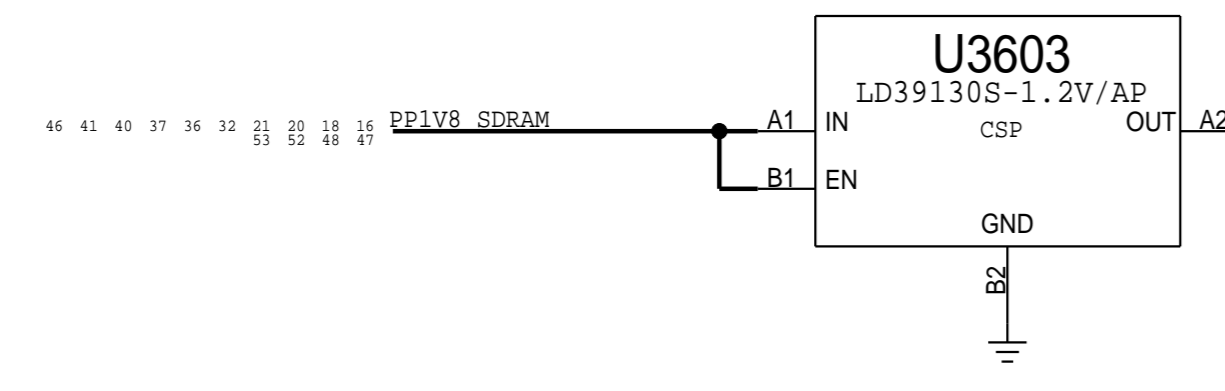

MAGGIE

APN: 336S00020

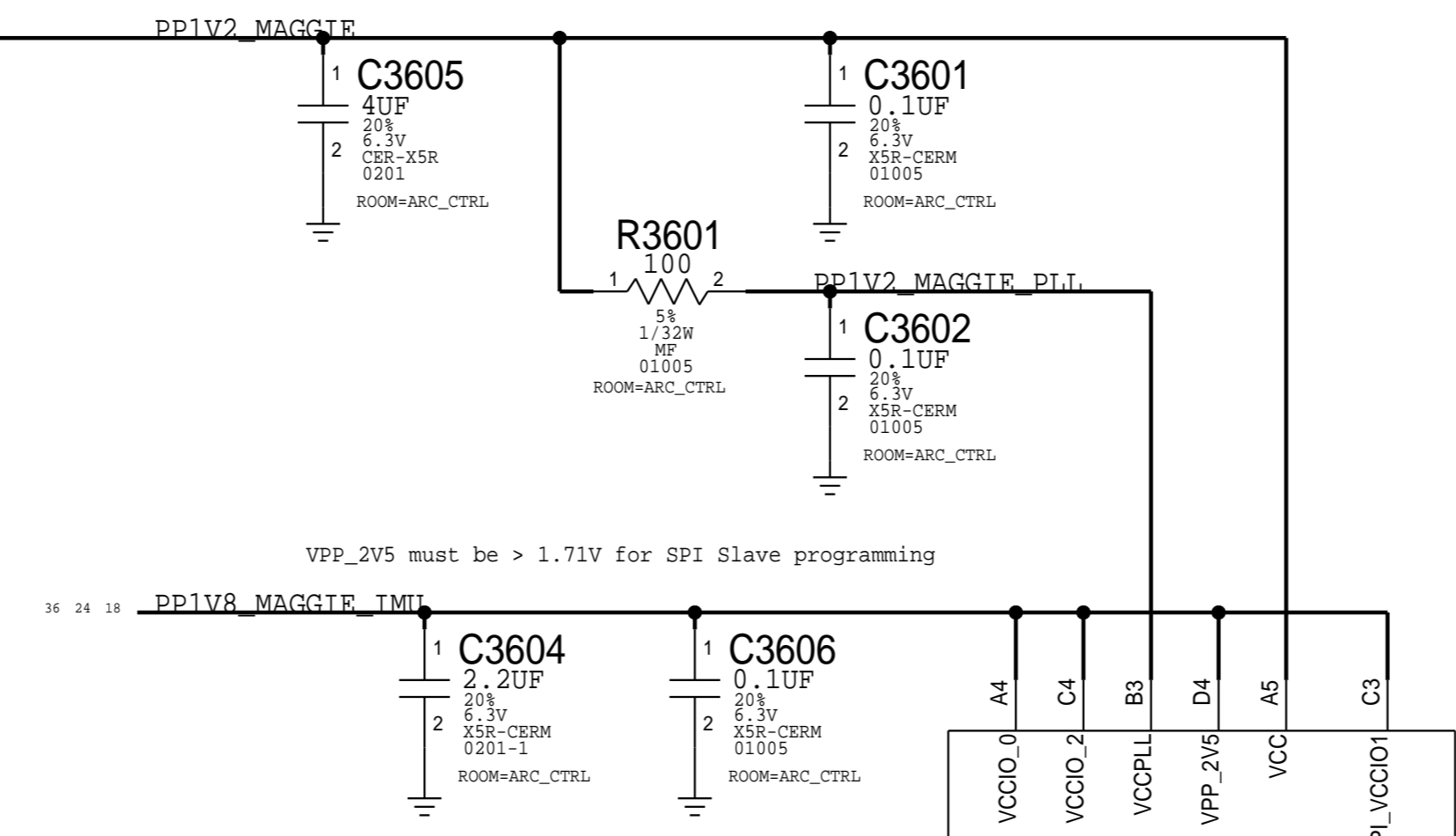

HOMER STM32L0 MICRO

STM32L03 APN: 337S00231

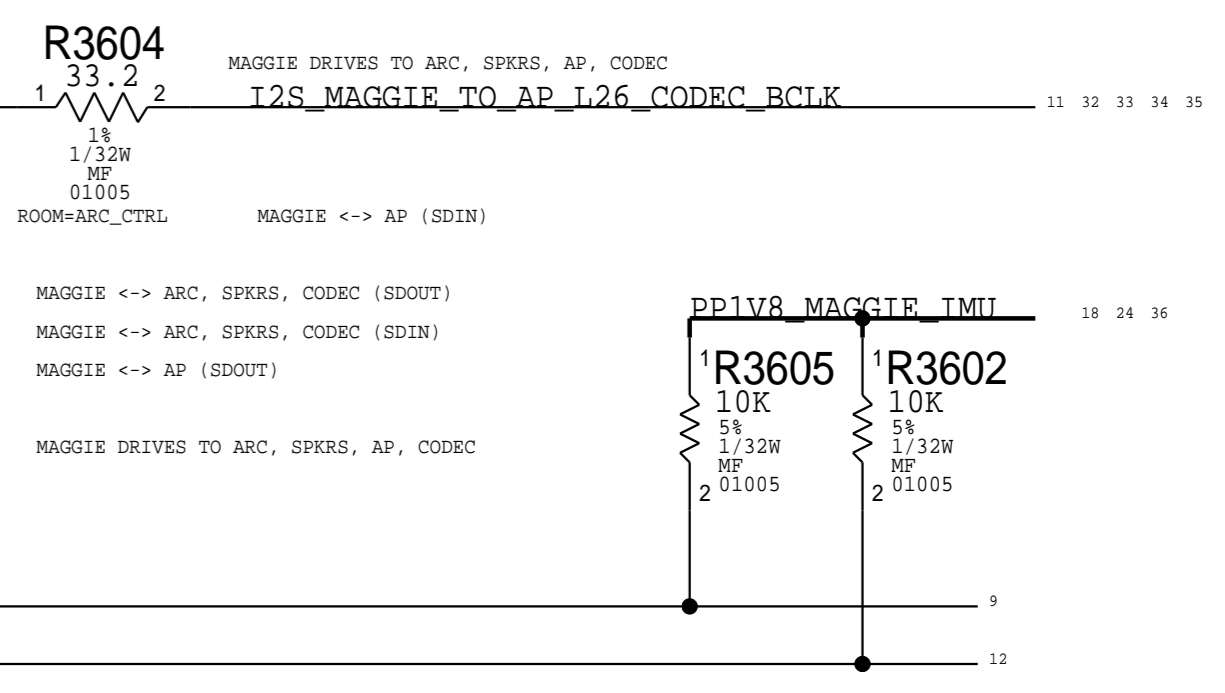
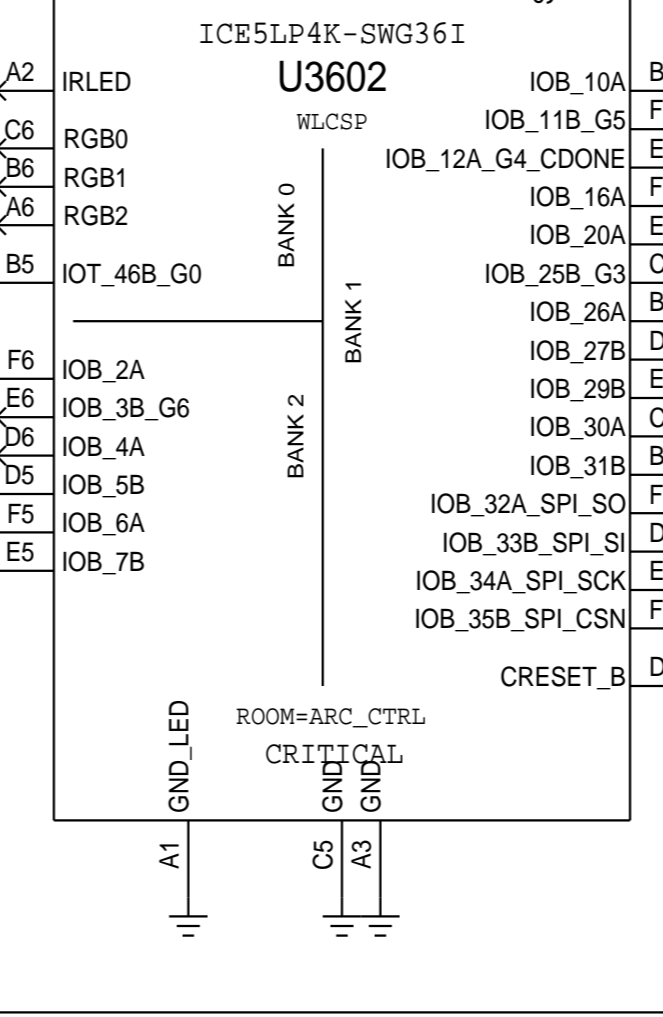
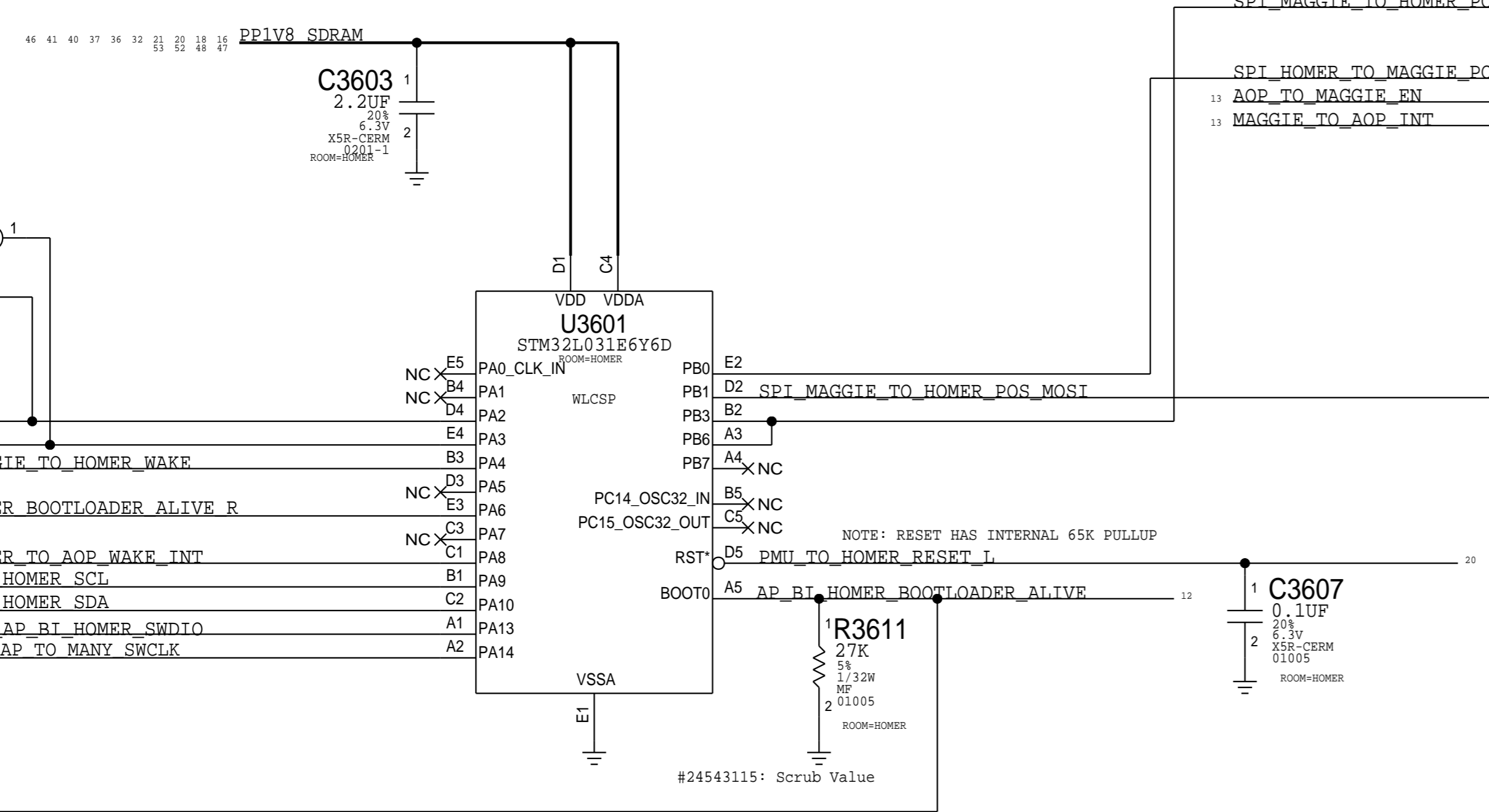

PAGE TITLE		ARC : MAGGIE	
Apple Inc.		DRAWING NUMBER	051-00482
NOTICE OF PROPRIETARY PROPERTY: THE INFORMATION CONTAINED HEREIN IS THE PROPRIETARY PROPERTY OF APPLE INC. THE POSSESSOR AGREES TO THE FOLLOWING: I TO MAINTAIN THIS DOCUMENT IN CONFIDENCE II NOT TO REPRODUCE OR COPY IT III NOT TO REVEAL OR PUBLISH IT IN WHOLE OR PART IV ALL RIGHTS RESERVED		REVISION	8.0.0
		BRANCH	
		PAGE	36 OF 53
		SHEET	36 OF 81

DISPLAY & TOUCH - POWER SUPPLIES

CHESTNUT DISPLAY PMU

APN:338S1172

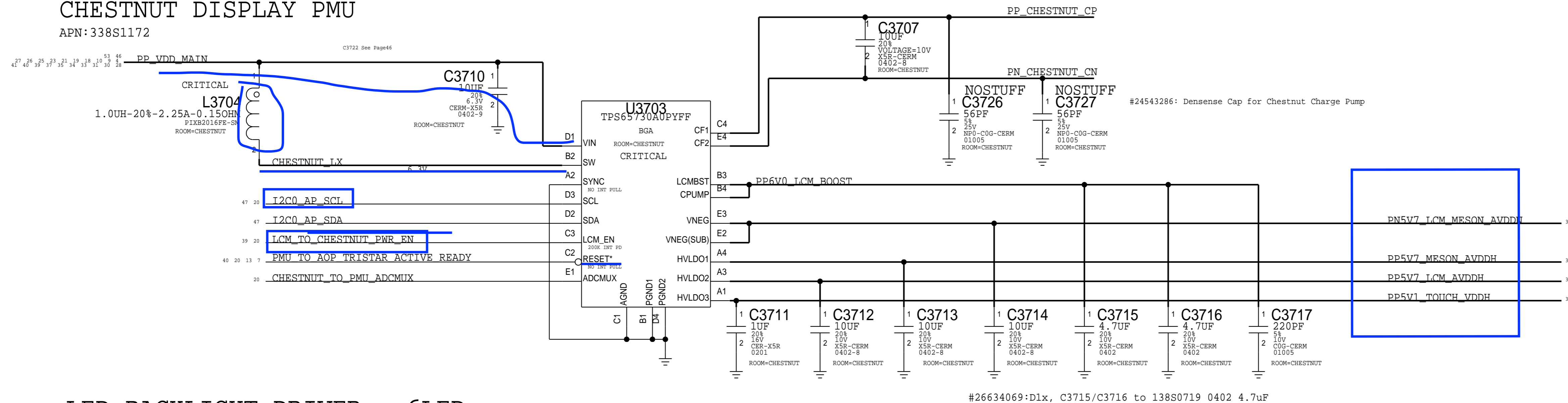

LED BACKLIGHT DRIVER - 6LED

APN:353S00640

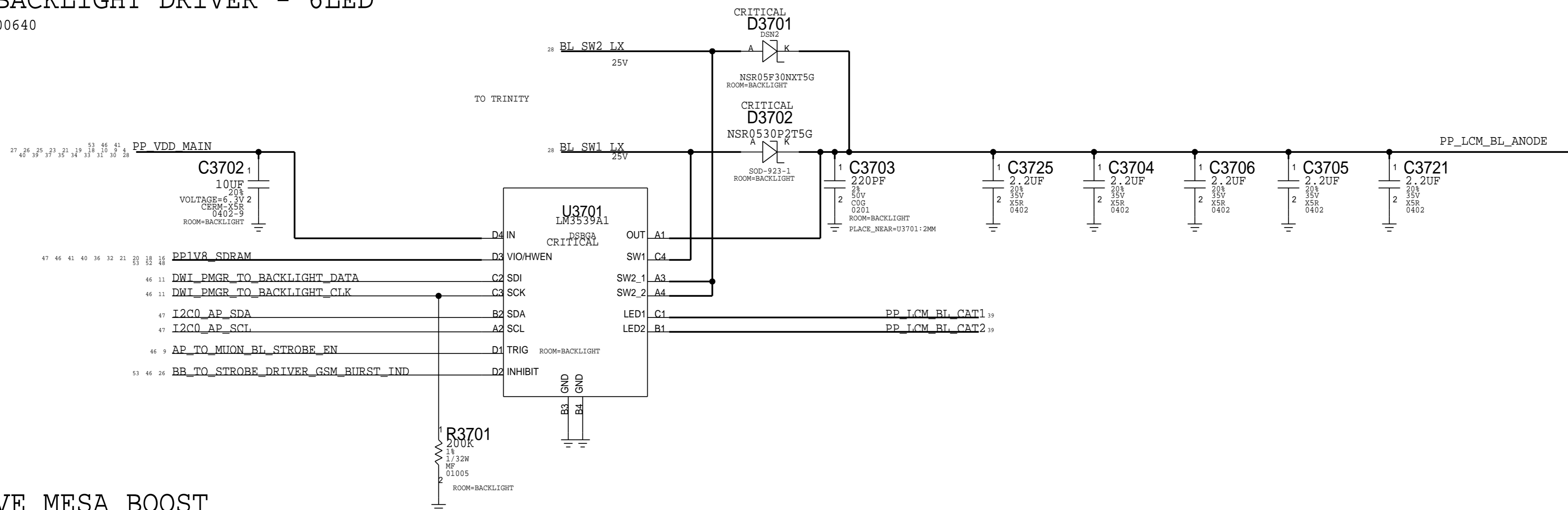

MOJAVE MESA BOOST

APN:353S00671

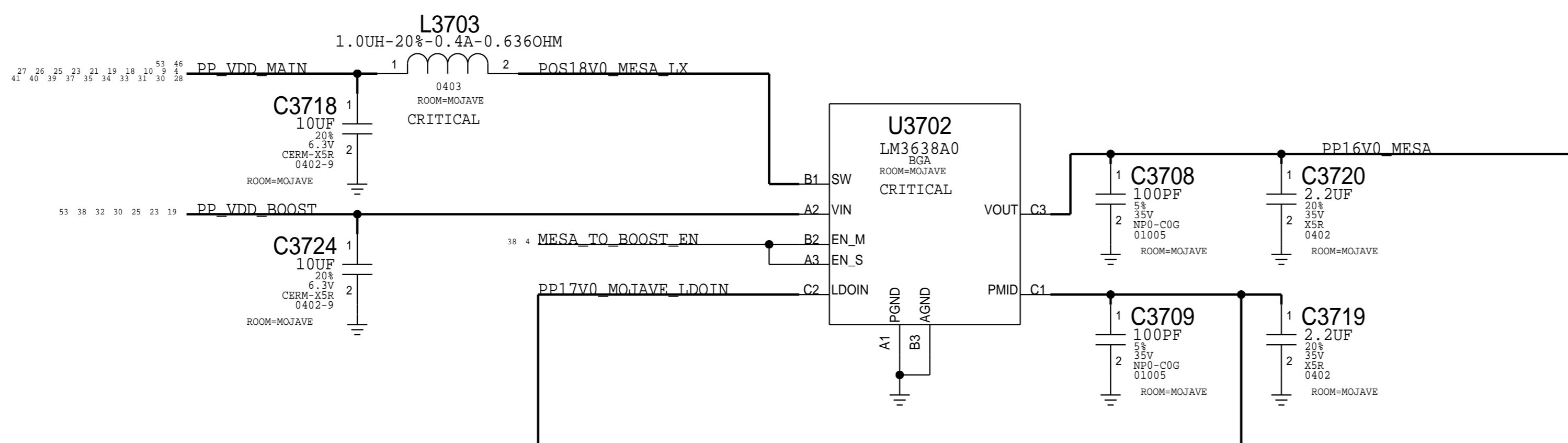

VIETMOBILE.VN

PAGE TITLE		DISPLAY & MESA:POWER	
Apple Inc.		DRAWING NUMBER	051-00482
		REVISION	8.0.0
NOTICE OF PROPRIETARY PROPERTY:		BRANCH	
THE INFORMATION CONTAINED HEREIN IS THE PROPRIETARY PROPERTY OF APPLE INC. THE POSSESSOR AGREES TO THE FOLLOWING:		PAGE	37 OF 53
I TO MAINTAIN THIS DOCUMENT IN CONFIDENCE		SHEET	37 OF 81
II NOT TO REPRODUCE OR COPY IT			
III NOT TO REVEAL OR PUBLISH IT IN WHOLE OR PART			
IV ALL RIGHTS RESERVED			

MESA POWER

MAMBA AND MESA CONNECTOR

MLB: 516S00141 (RCPT)
FLEX: 516S00142 (PLUG)

CRITICAL
J3801

BB35C-RA24-3A
P-ST-SM

Matches flex_x452_acf, schematic revision 1.5.0 pinout

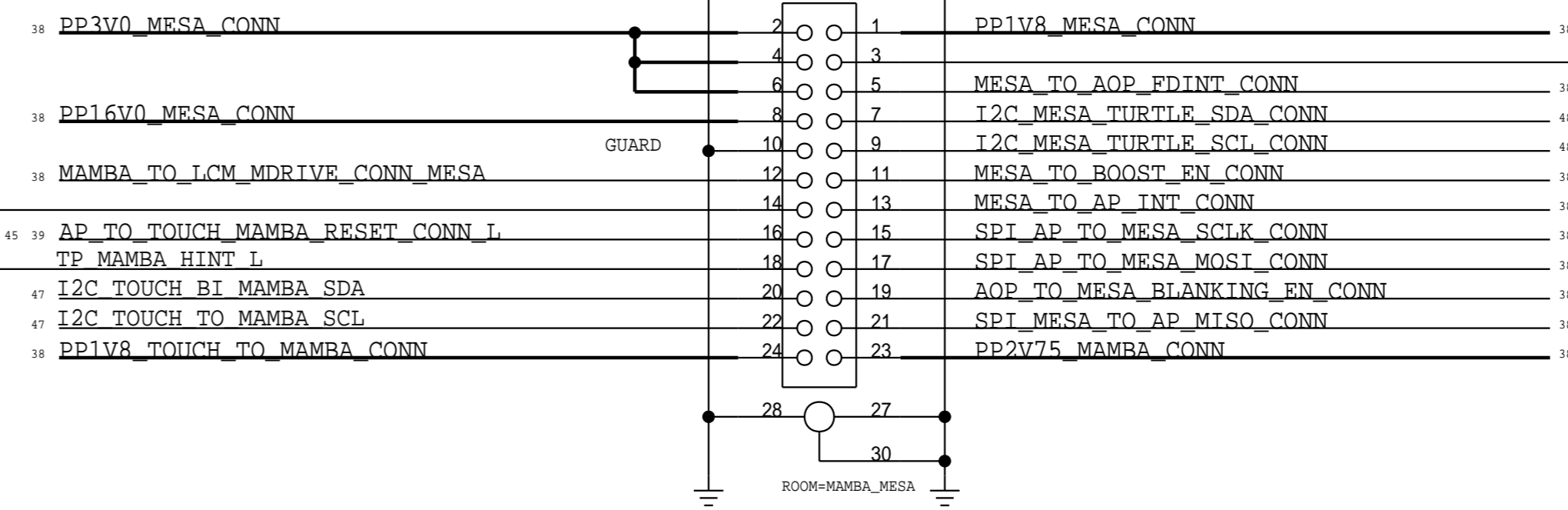
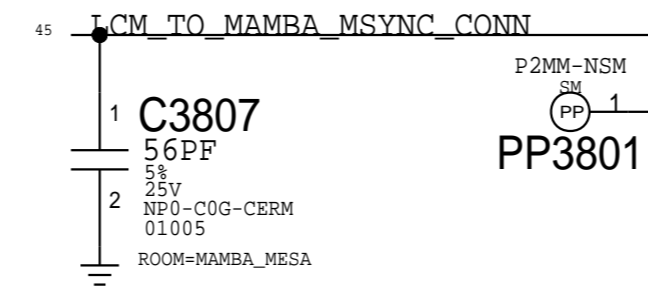
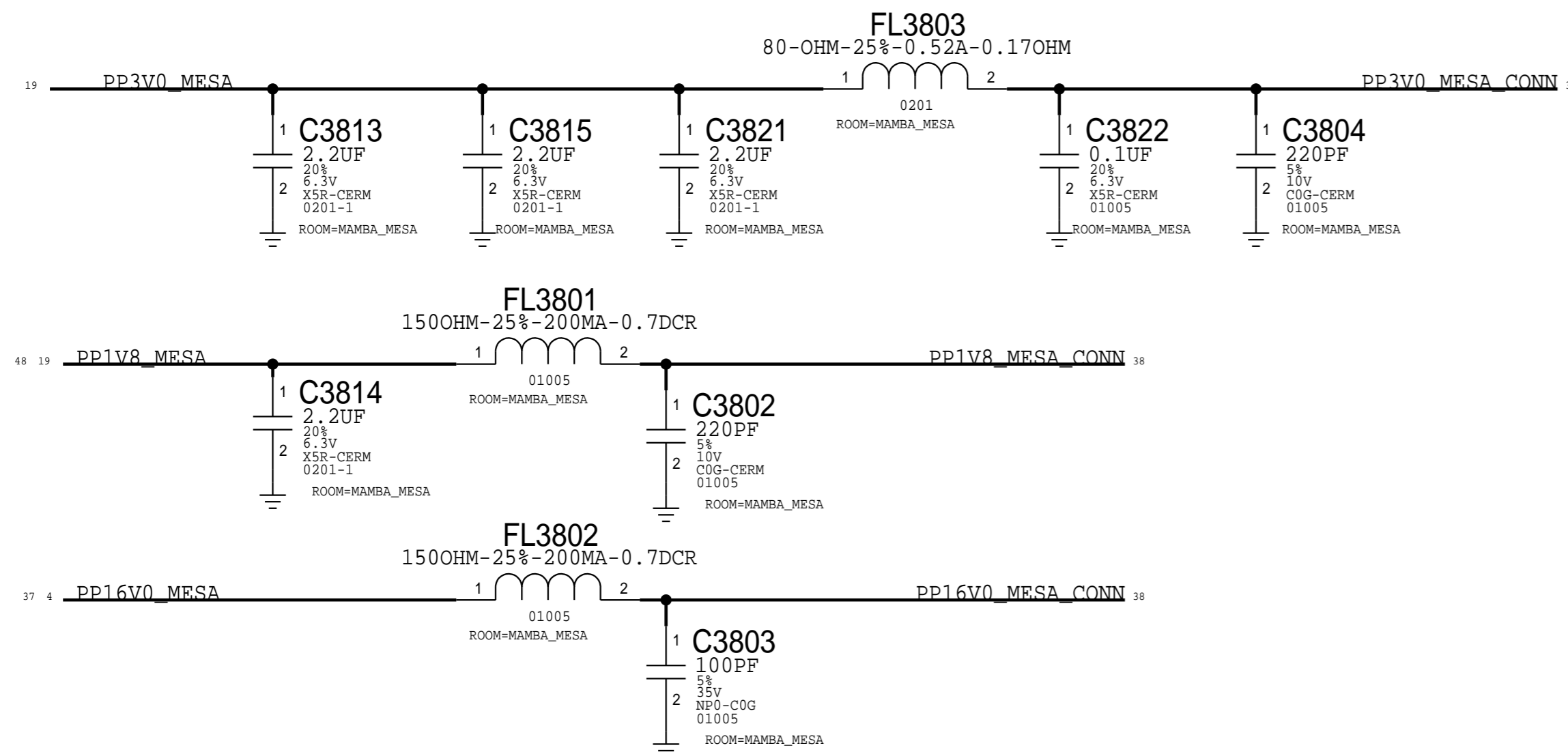

MESA DIGITAL I/O

MAMBA POWER

NOTE: OUTPUT IMPEDANCE MUST BE >0.005-OHM
IN ORDER TO MEET CAP BSR REQUIREMENT PER LDO SPEC.
VENDOR ALSO RECOMMENDS CIN = COUT FOR STABILITY

TI:353800576
ST:353800932

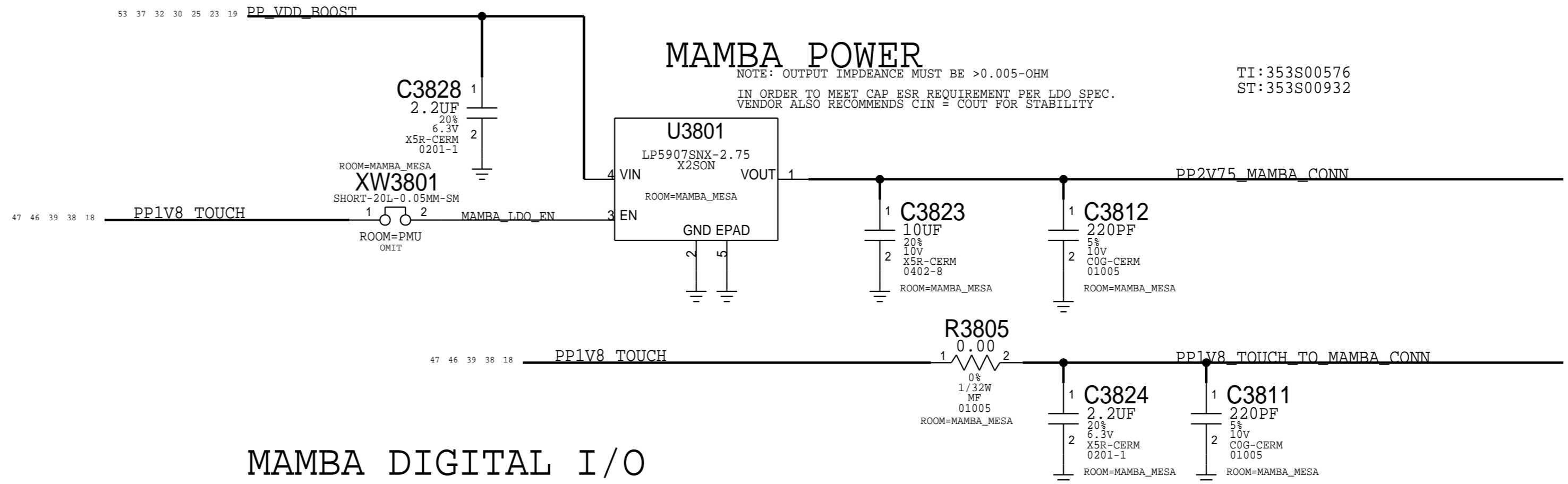

MAMBA DIGITAL I/O

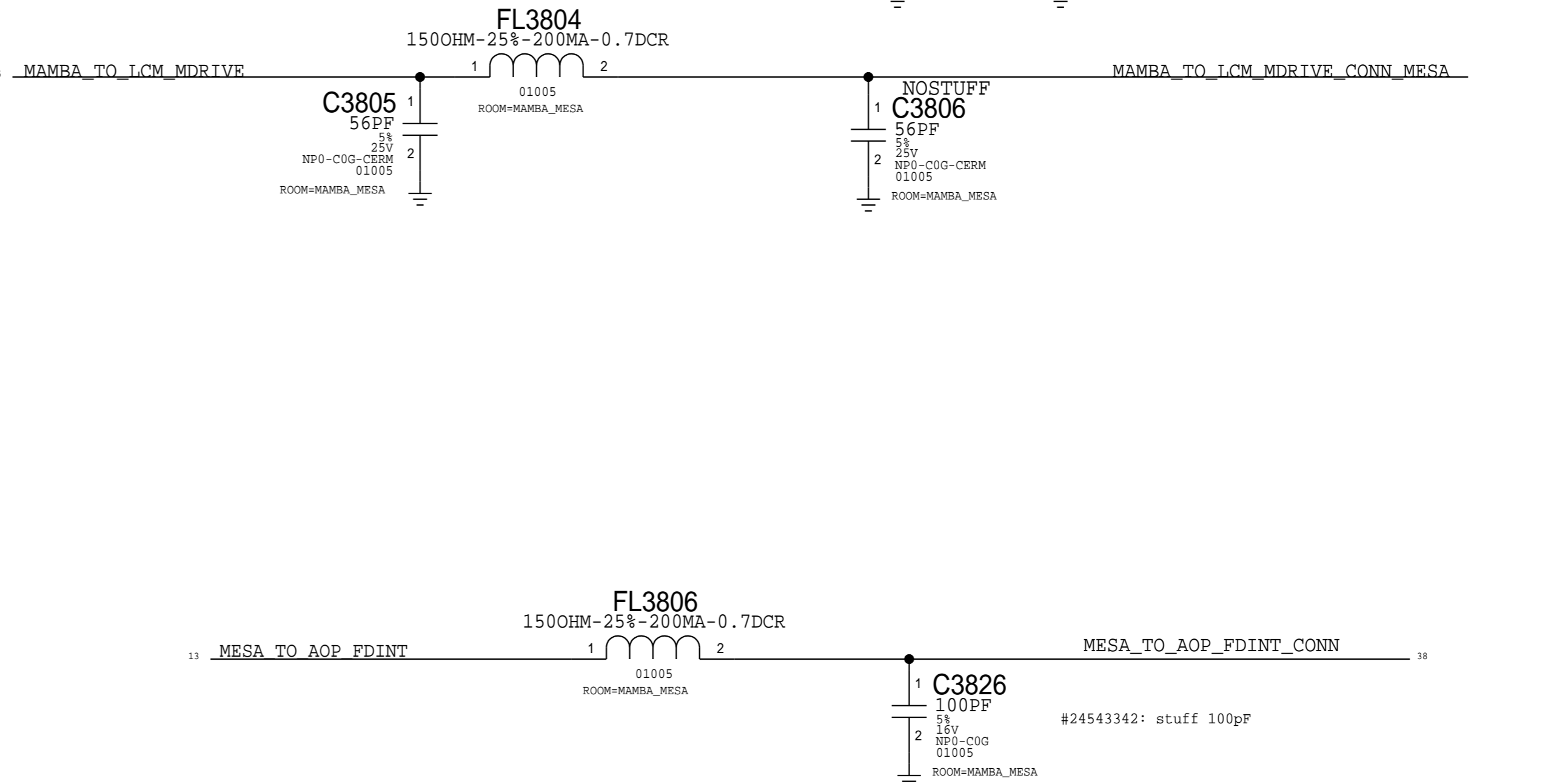
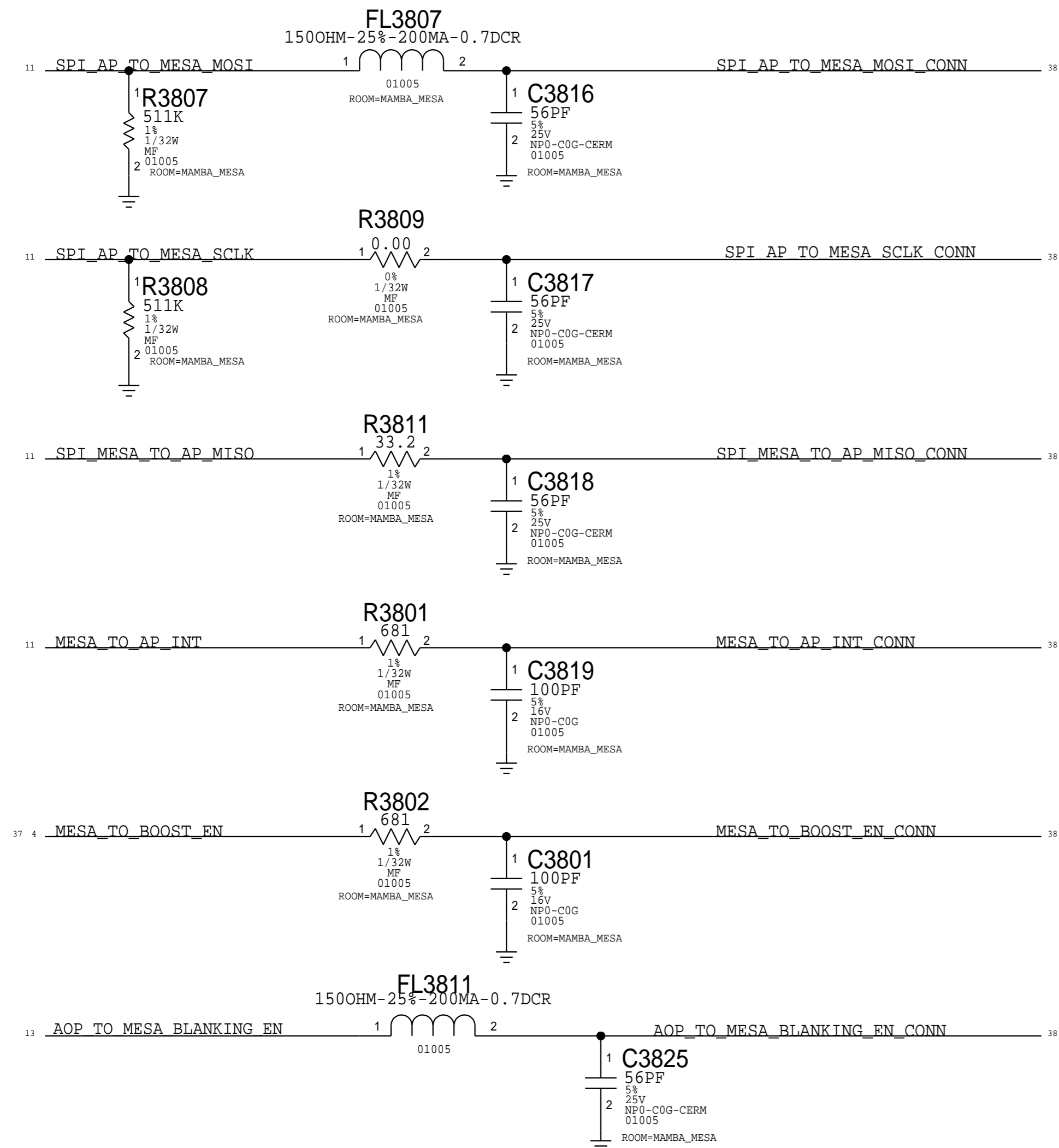

PAGE TITLE		B2B:ORB & MESA	
Apple Inc.		DRAWING NUMBER	051-00482
		REVISION	8.0.0
NOTICE OF PROPRIETARY PROPERTY: THE INFORMATION CONTAINED HEREIN IS THE PROPRIETARY PROPERTY OF APPLE INC. THE POSSESSOR AGREES TO THE FOLLOWING: I TO MAINTAIN THIS DOCUMENT IN CONFIDENCE II NOT TO REPRODUCE OR COPY IT III NOT TO REVEAL OR PUBLISH IT IN WHOLE OR PART IV ALL RIGHTS RESERVED		BRANCH	
		PAGE	38 OF 53
		SHEET	38 OF 81

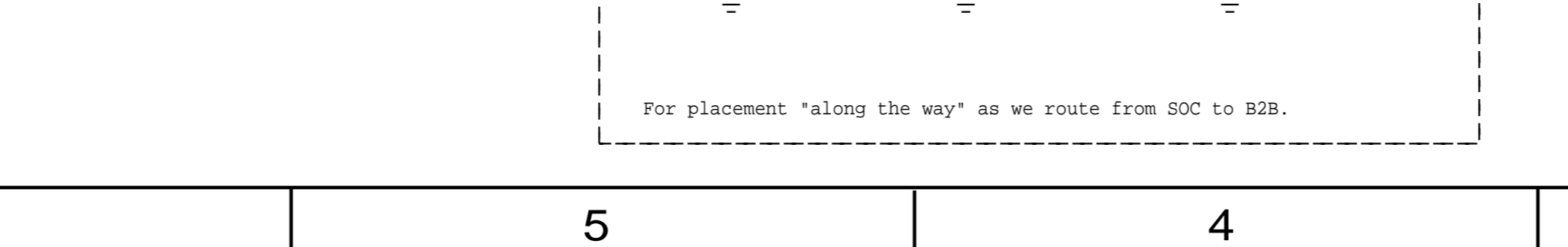
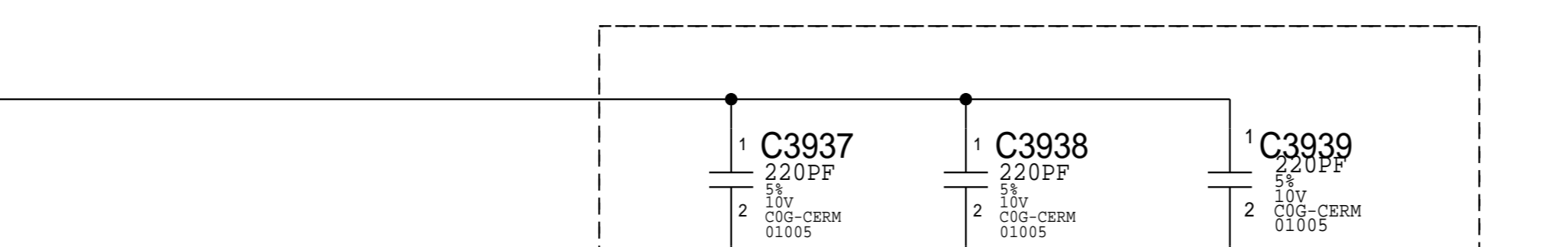
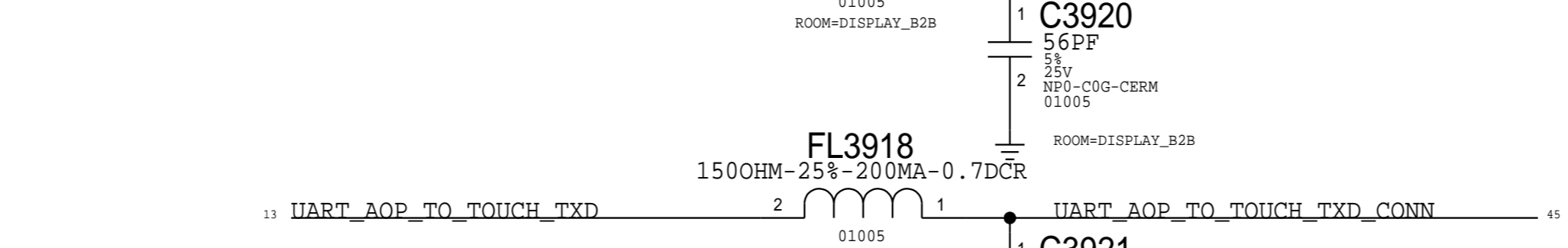
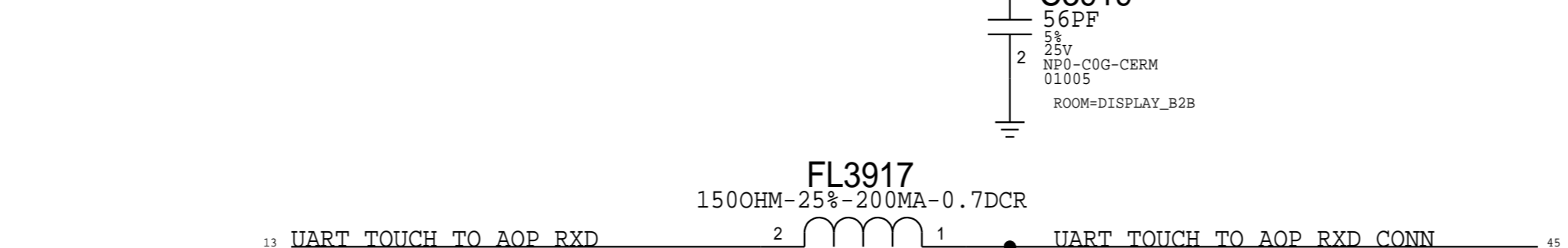
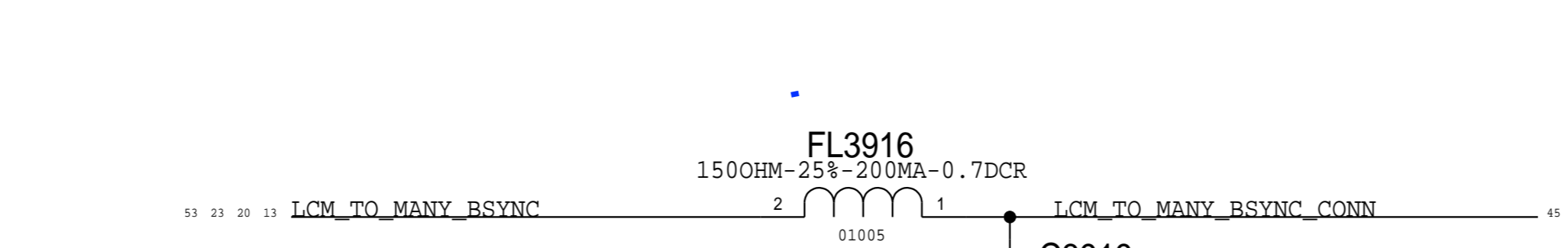
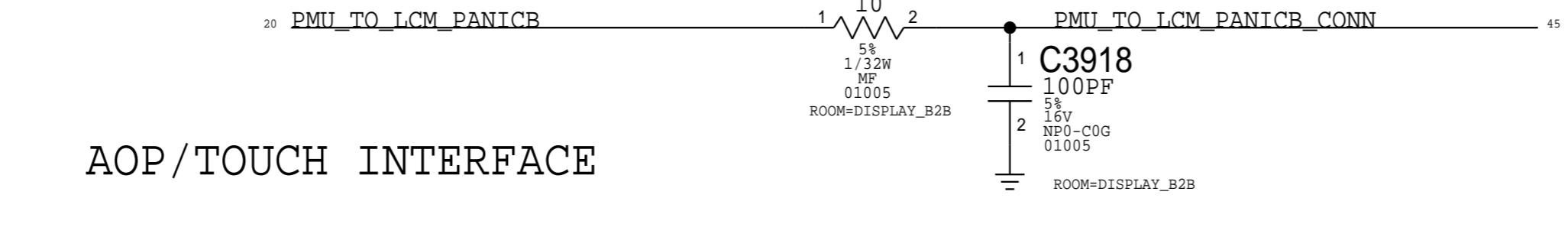
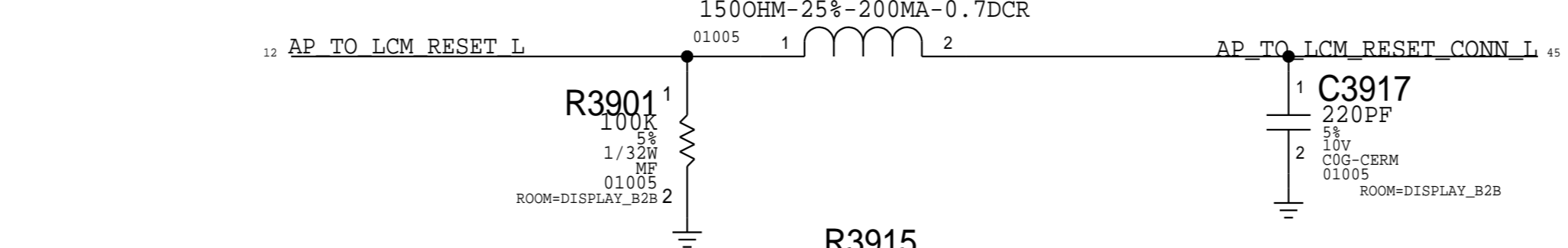
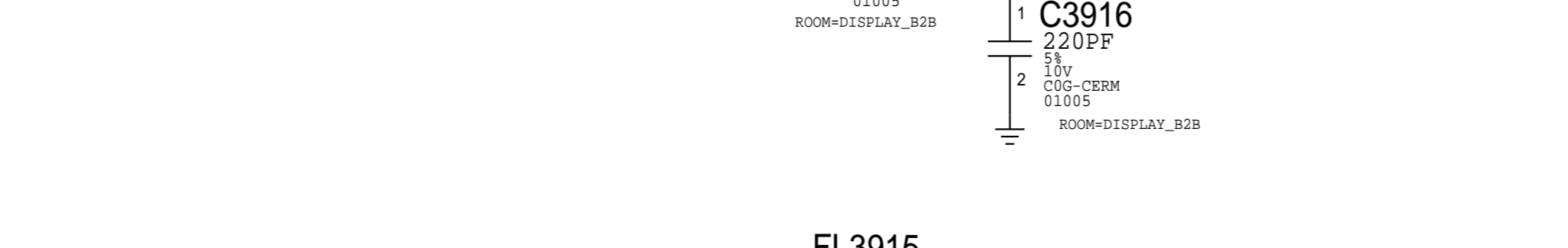
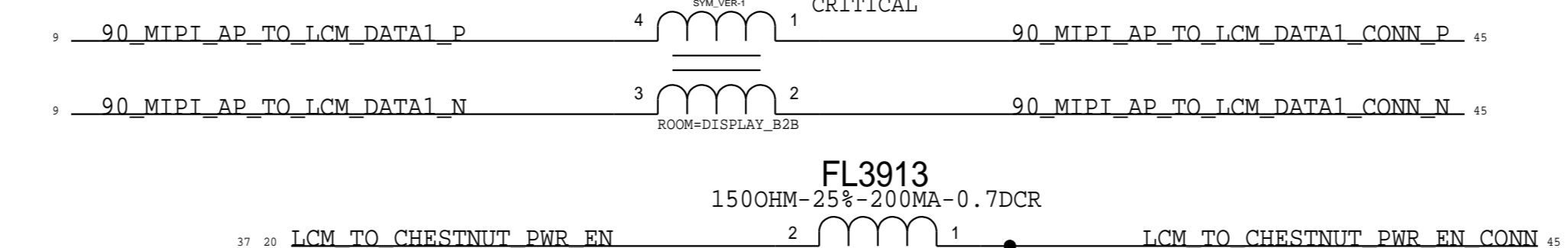
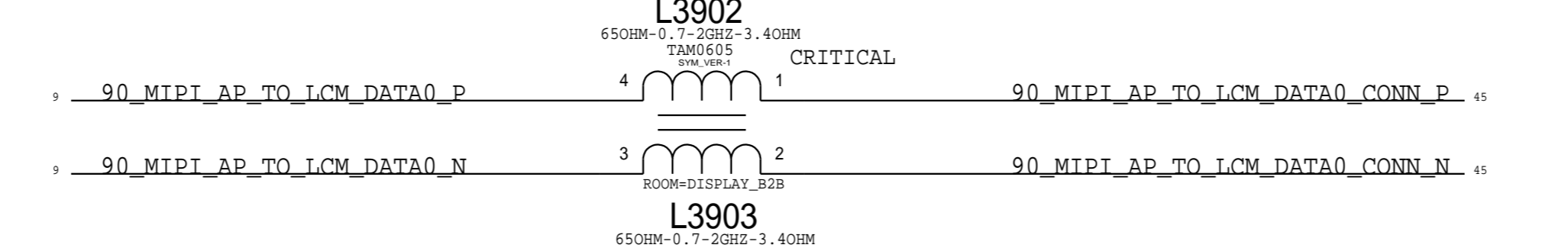
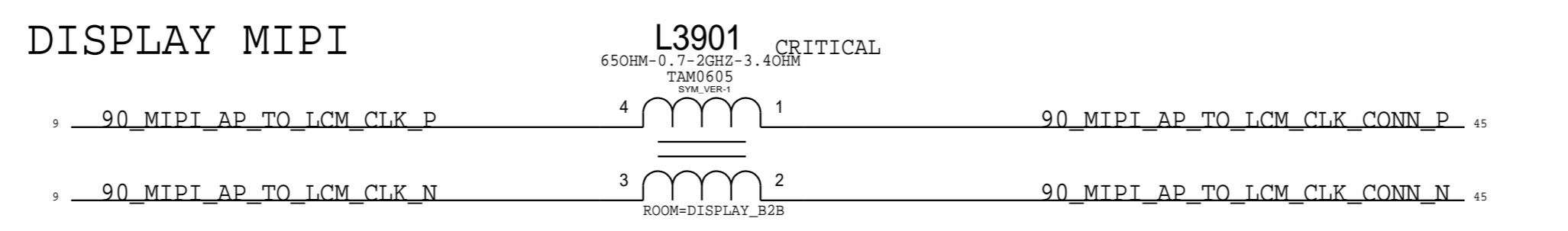
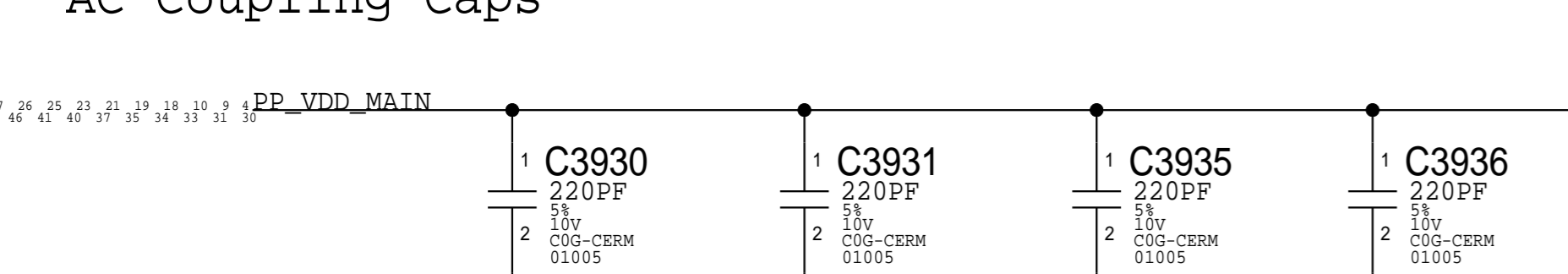
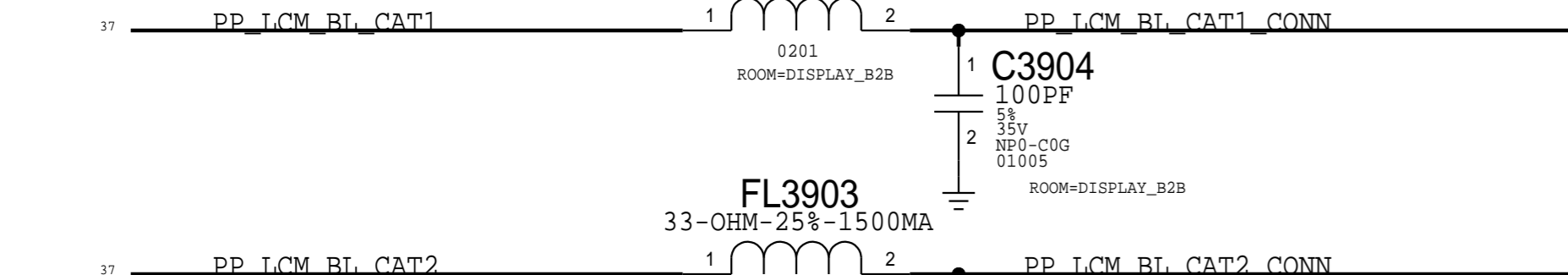
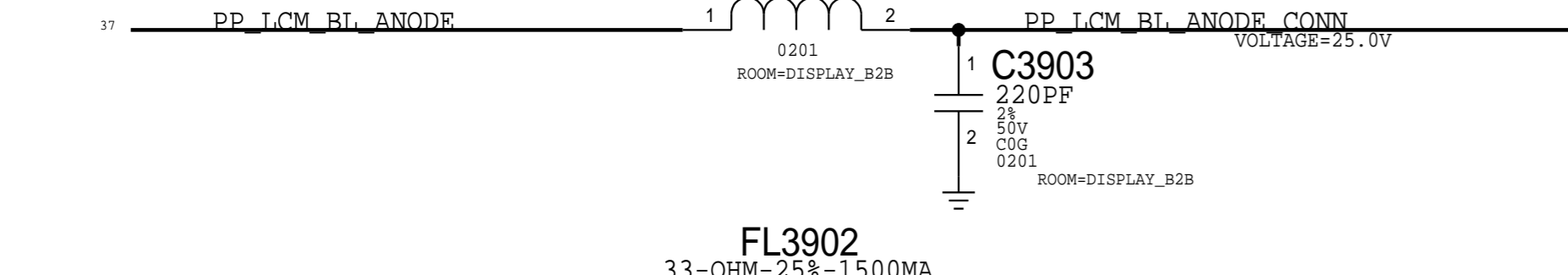
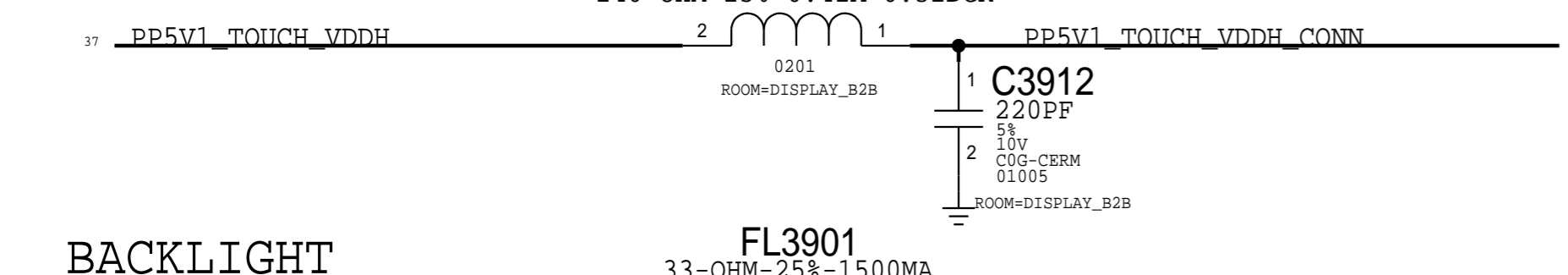
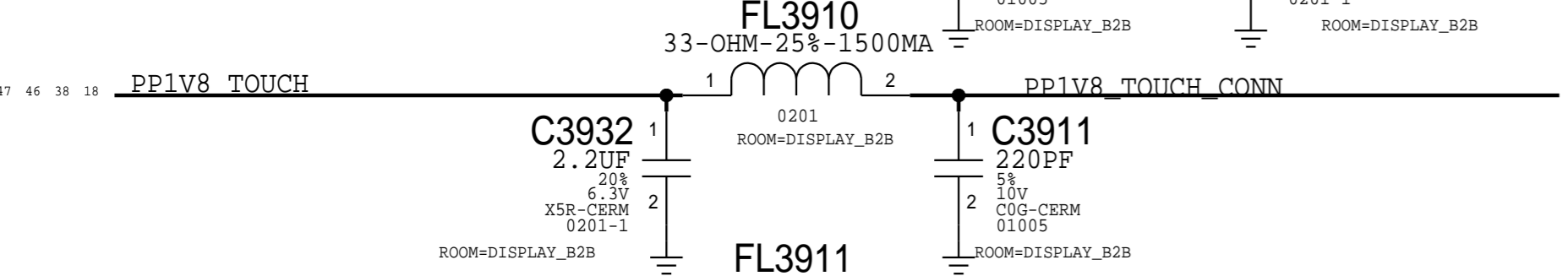
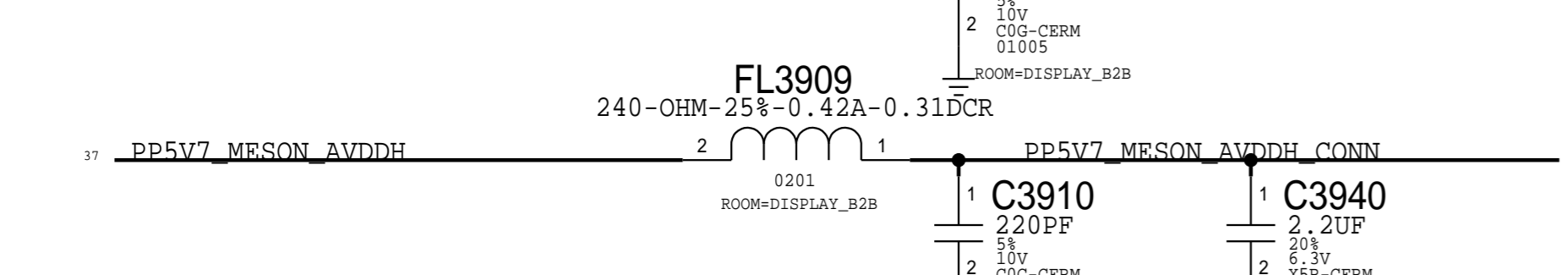
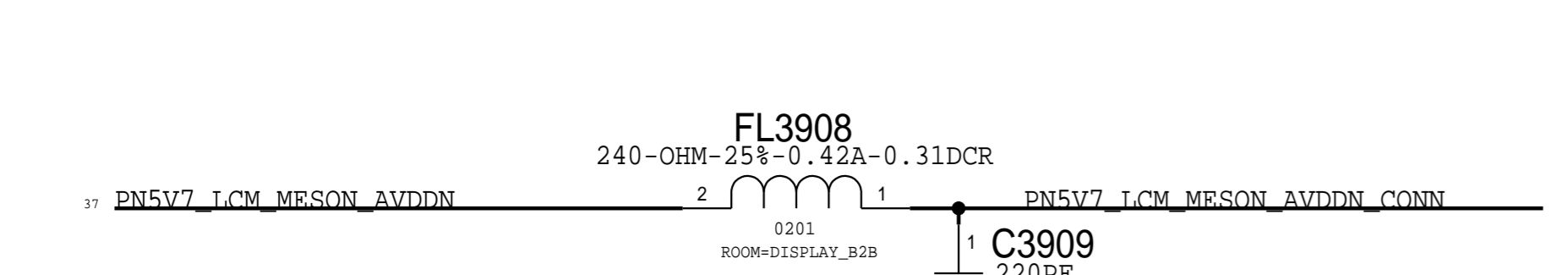
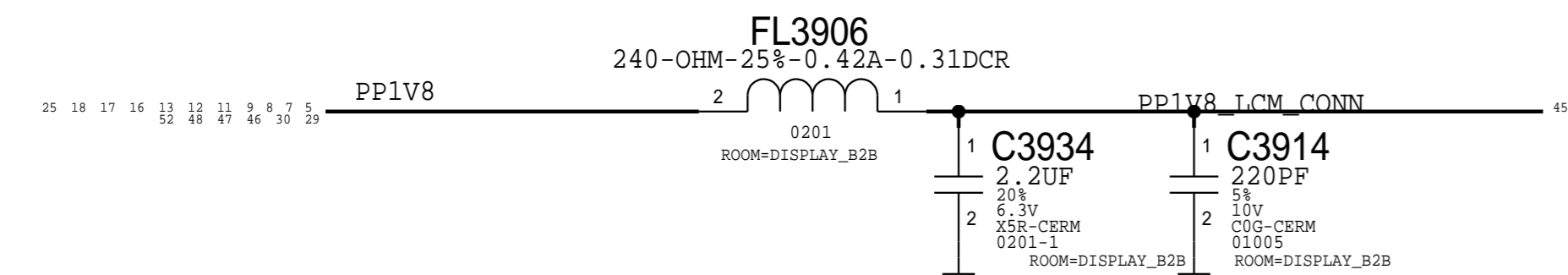
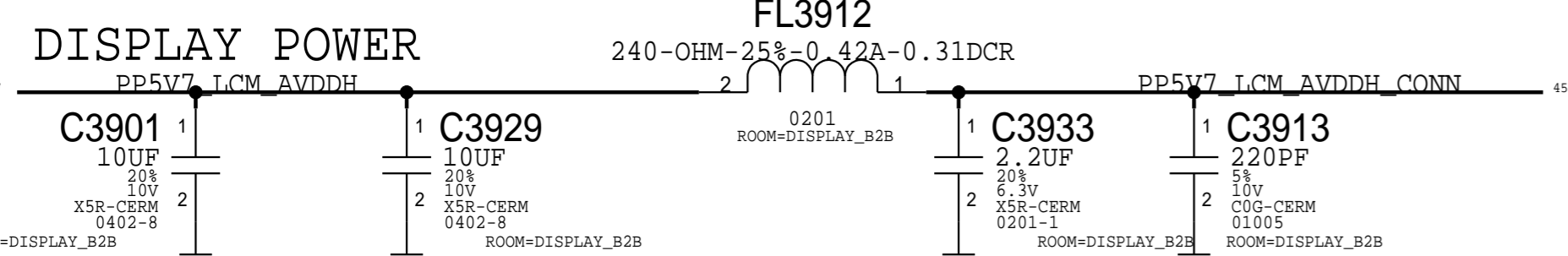

AP/TOUCH INTERFACE

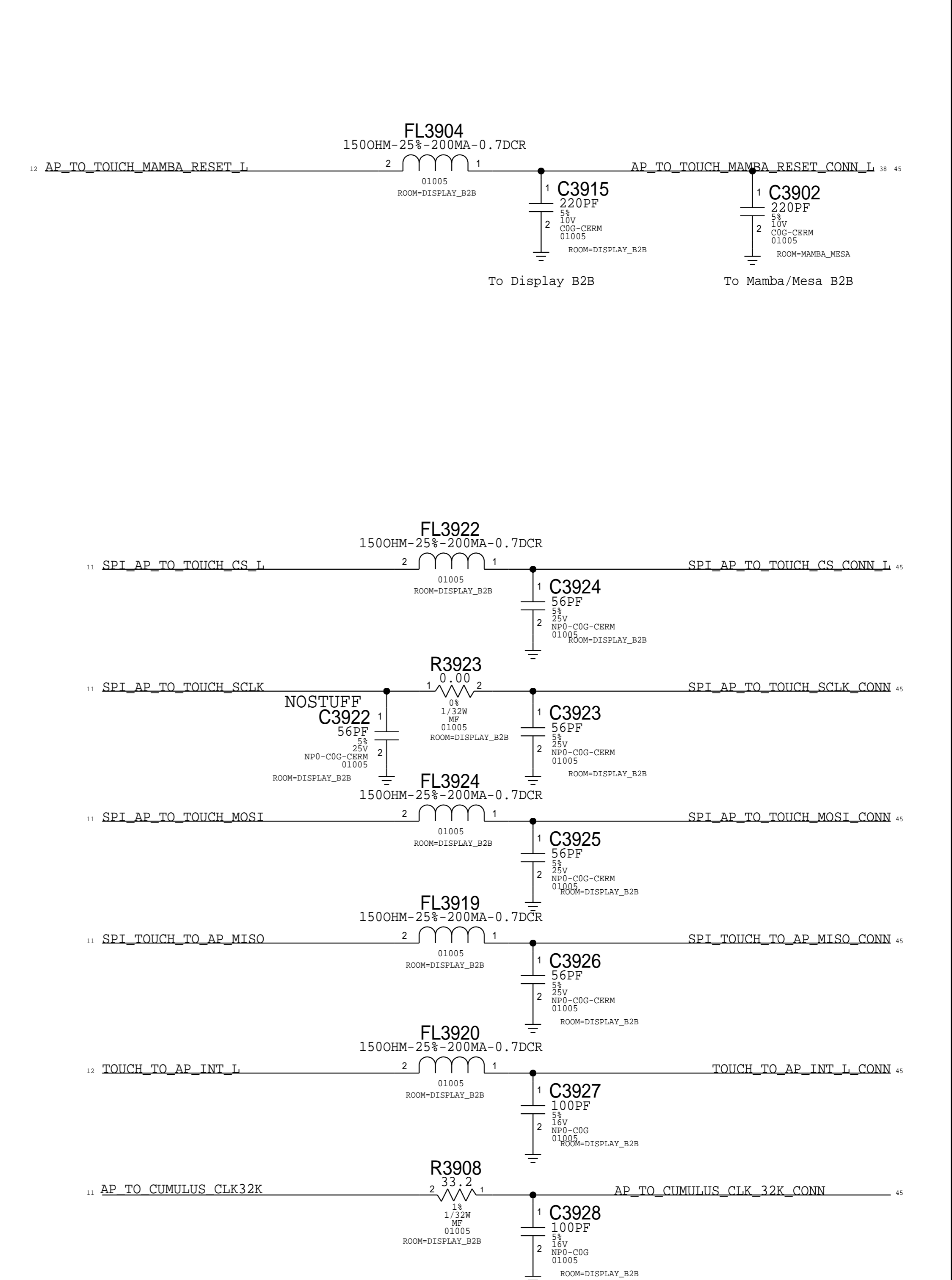

PAGE TITLE		B2B FILTERS: DISPLAY & TOUCH	
DRAWING NUMBER		051-00482	SIZE D
REVISION		8.0.0	
BRANCH			
PAGE		39 OF 53	
SHEET		39 OF 81	

Apple Inc.

NOTICE OF PROPRIETARY PROPERTY:
 THE INFORMATION CONTAINED HEREIN IS THE PROPRIETARY PROPERTY OF APPLE INC. THE POSSESSOR AGREES TO THE FOLLOWING:
 I TO MAINTAIN THIS DOCUMENT IN CONFIDENCE
 II NOT TO REPRODUCE OR COPY IT
 III NOT TO REVEAL OR PUBLISH IT IN WHOLE OR PART
 IV ALL RIGHTS RESERVED

TRISTAR 2

z=0.45mm
 <rdar://24285280> EVT: 343S00091 (P2:343S00078)

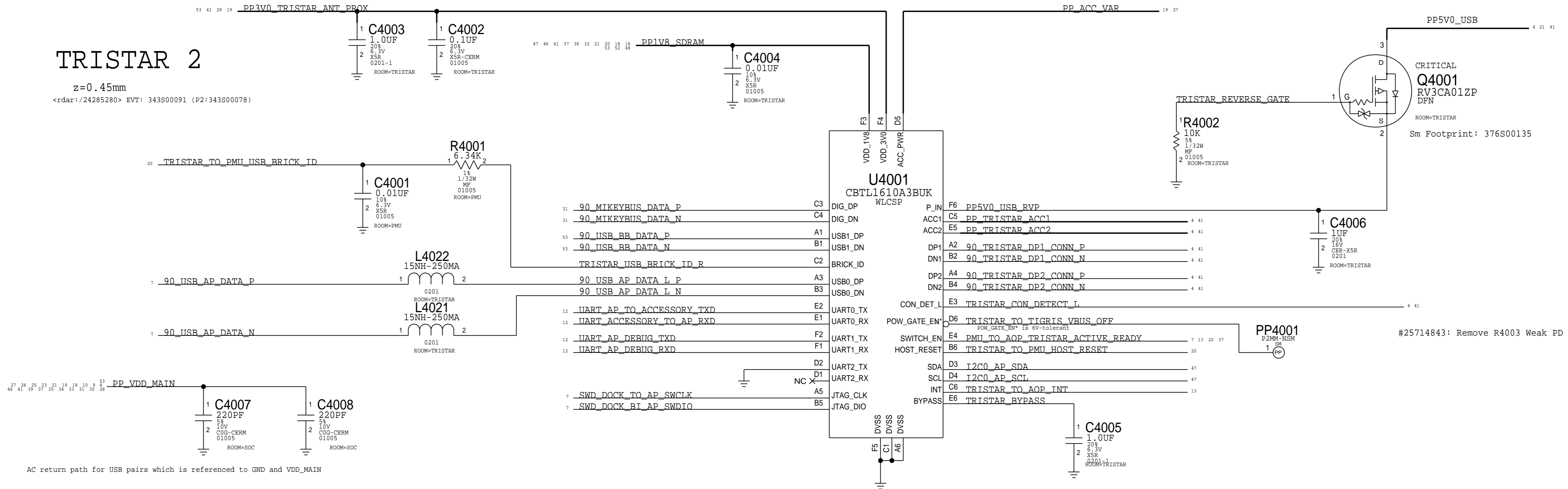

PAGE TITLE			TRISTAR 2		
Apple Inc.		DRAWING NUMBER	051-00482	SIZE	D
		REVISION	8.0.0		
NOTICE OF PROPRIETARY PROPERTY:		BRANCH			
THE INFORMATION CONTAINED HEREIN IS THE PROPRIETARY PROPERTY OF APPLE INC. THE POSSESSOR AGREES TO THE FOLLOWING:		PAGE	40 OF 53		
I TO MAINTAIN THIS DOCUMENT IN CONFIDENCE		SHEET	40 OF 81		
II NOT TO REPRODUCE OR COPY IT					
III NOT TO REVEAL OR PUBLISH IT IN WHOLE OR PART					
IV ALL RIGHTS RESERVED					

ANTENNA

Please loop in Matt Mow (Antenna Team) when changing these components!

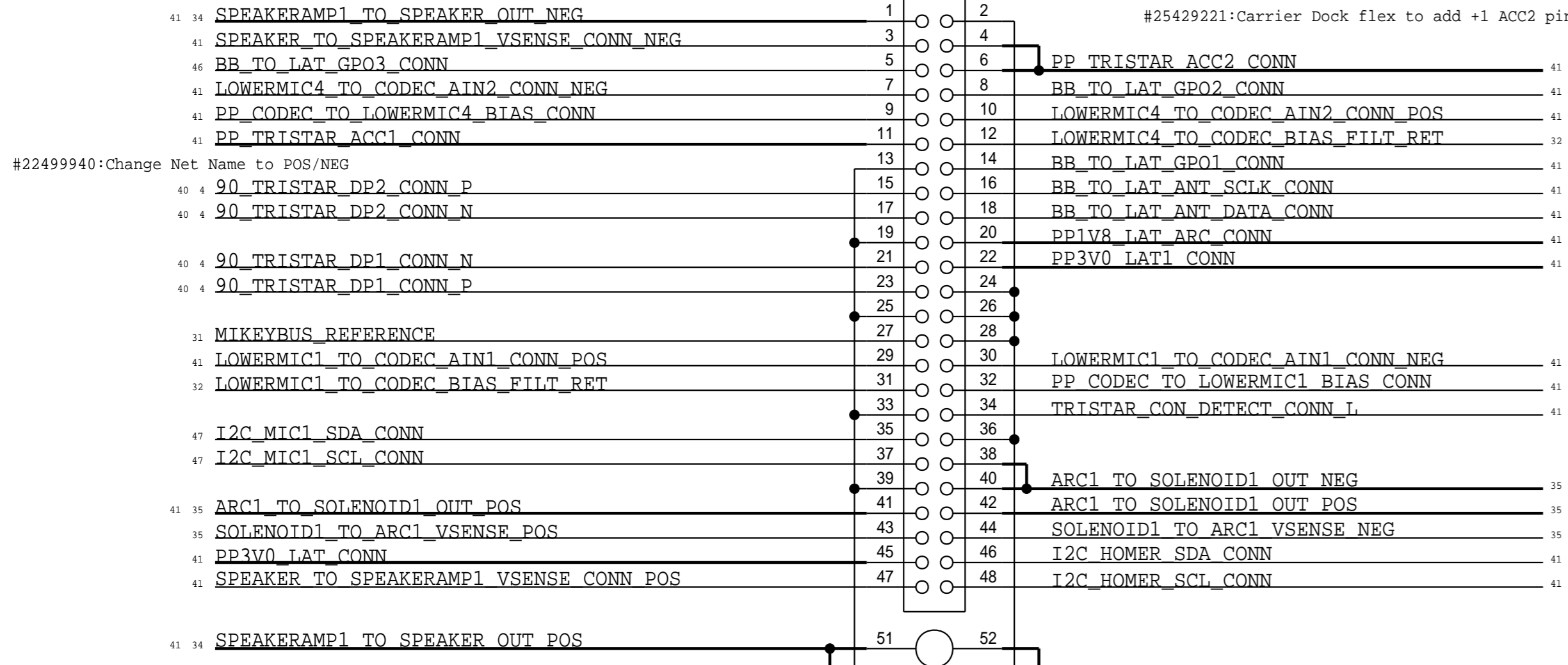
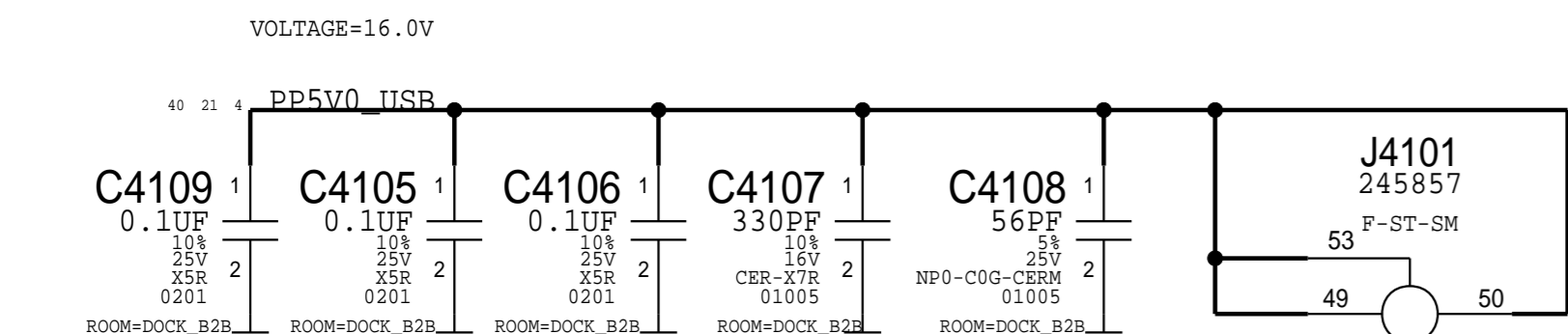
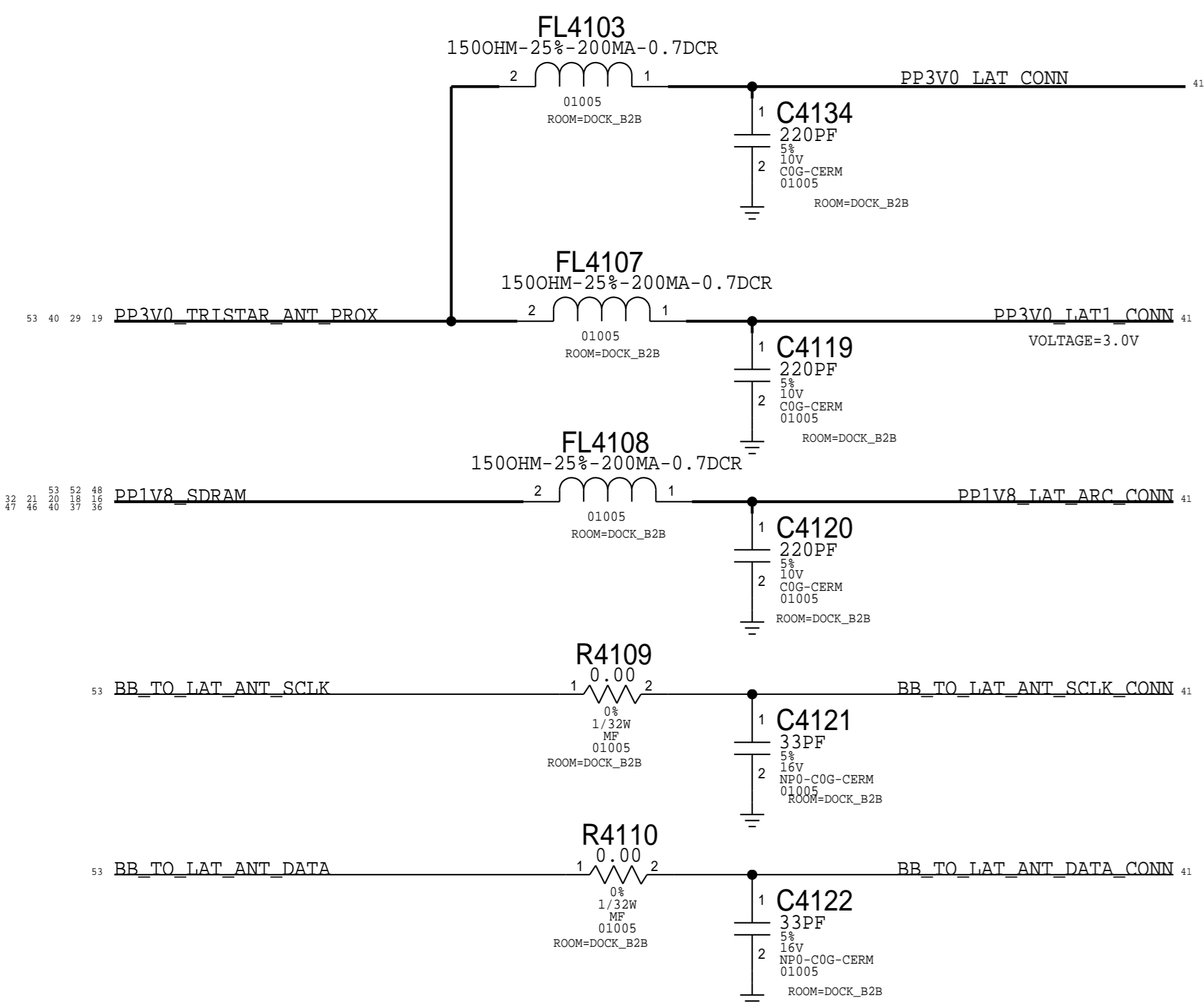

DOCK FLEX CONNECTOR

ARC CONTROL

#26118161: Update FL4104 to 49.9ohm

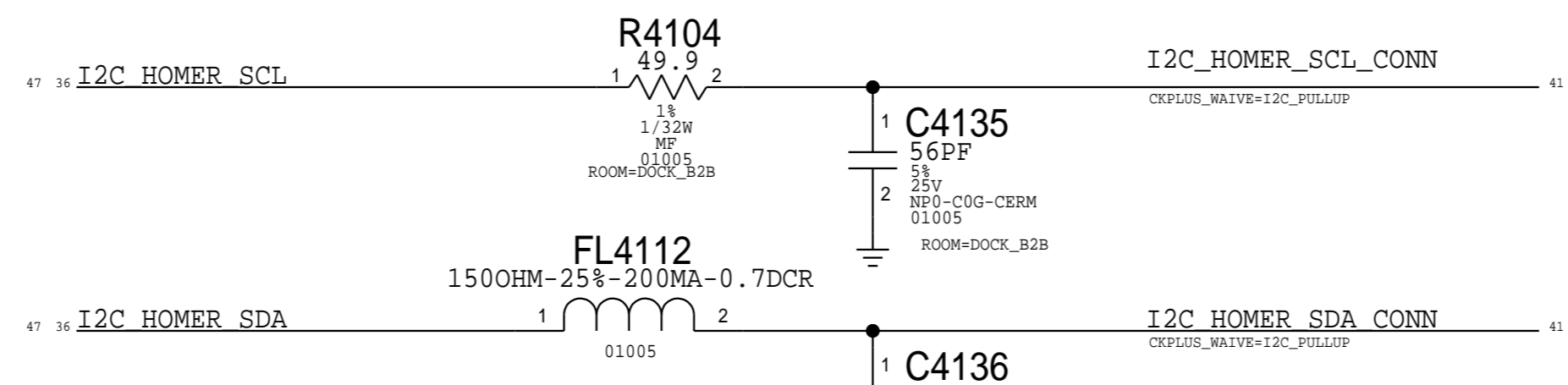

ARC1

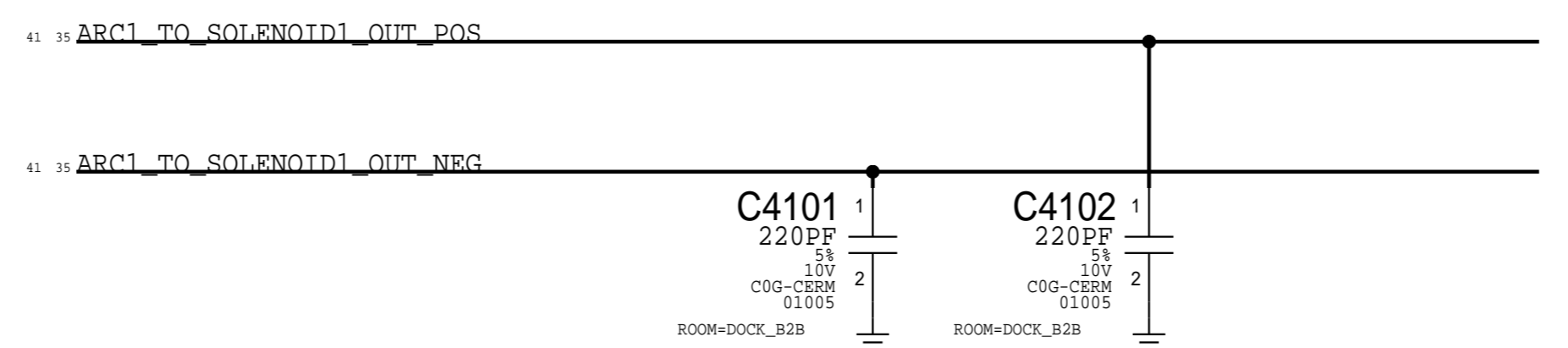

Antenna GPIO

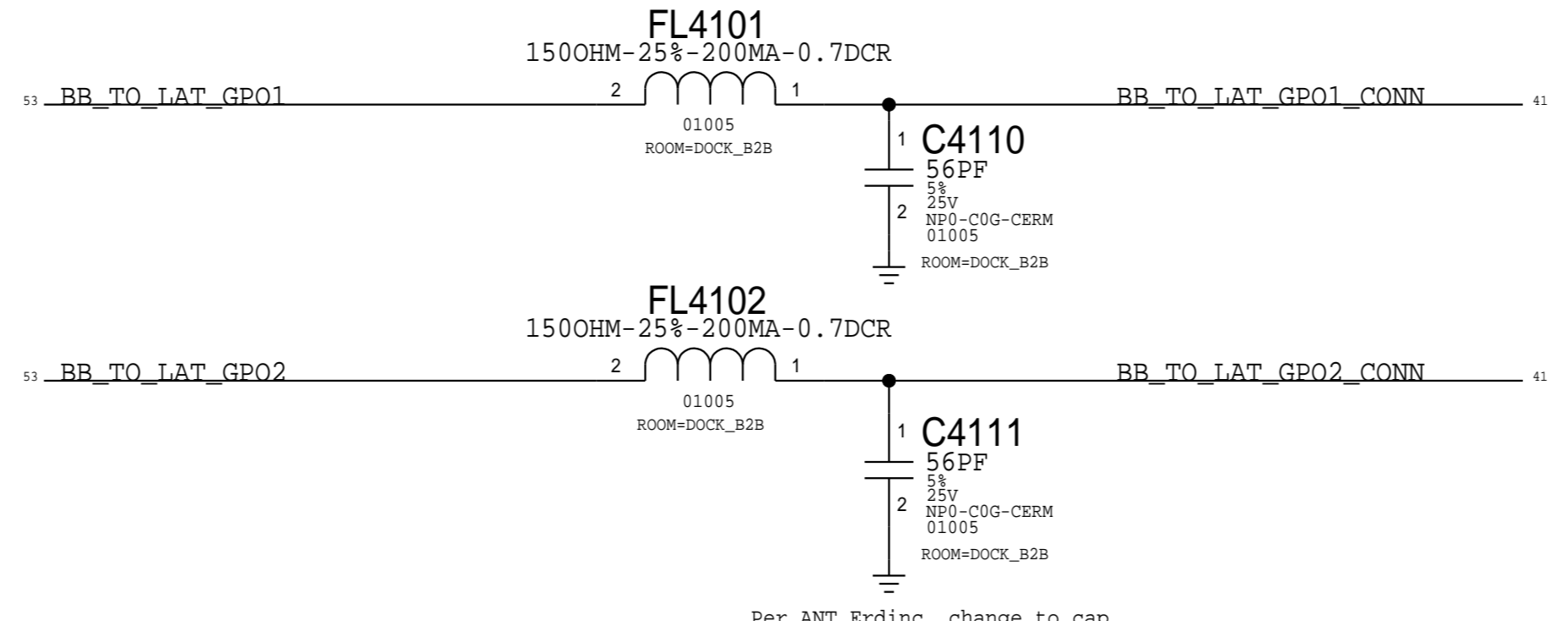

Per ANT Erdinc, change to cap

TRISTAR

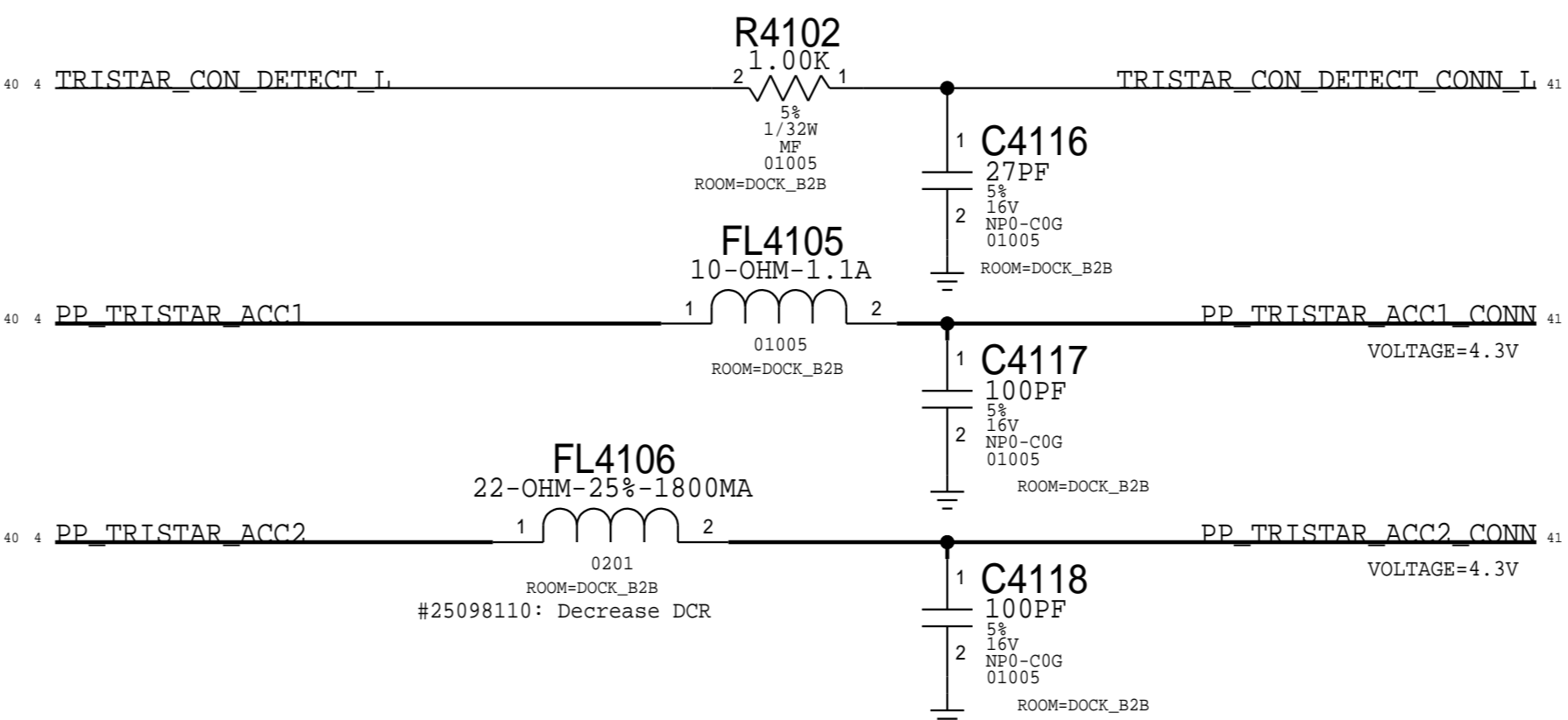

LOWER MIC1/4

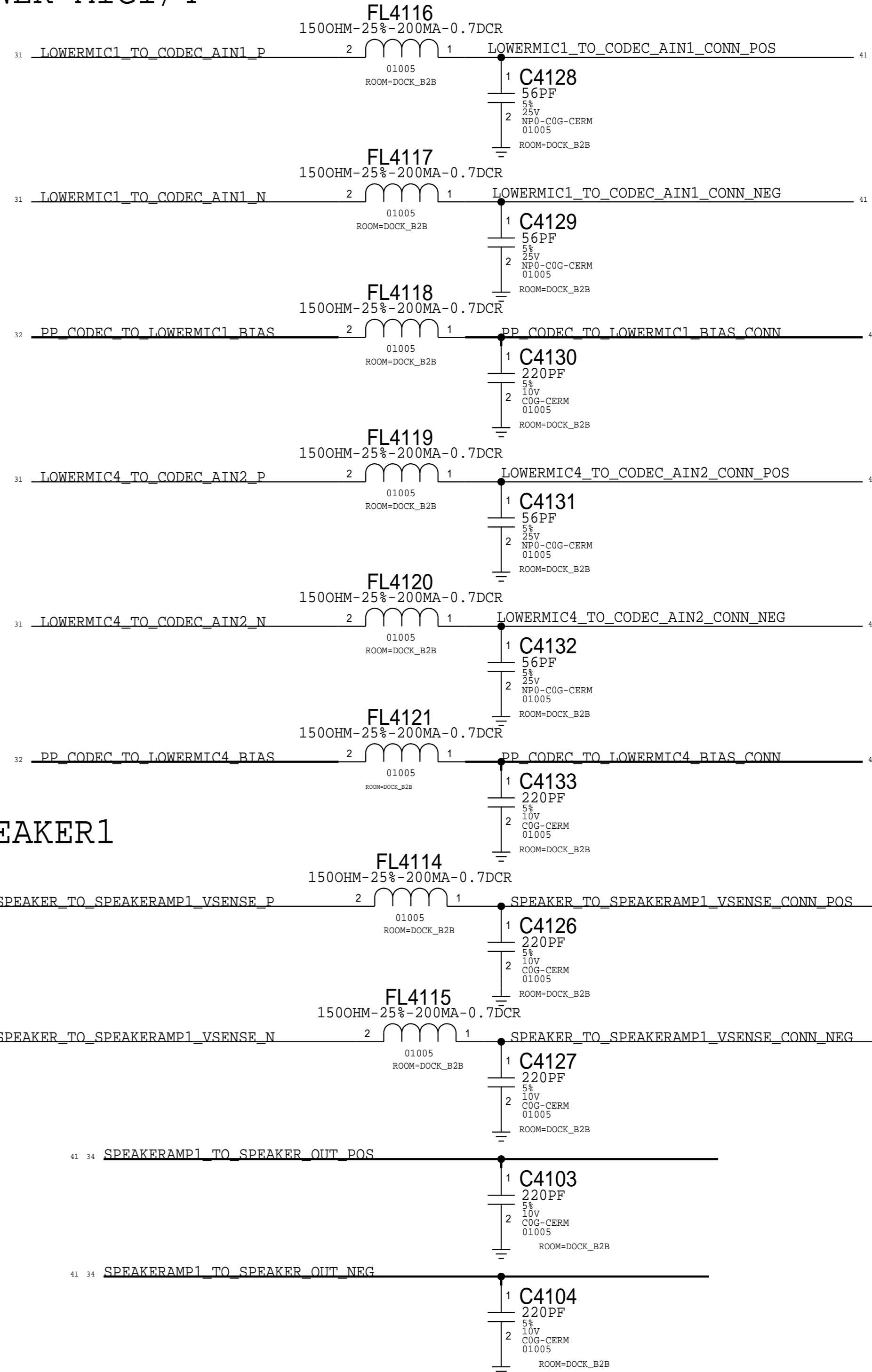

SPEAKER1

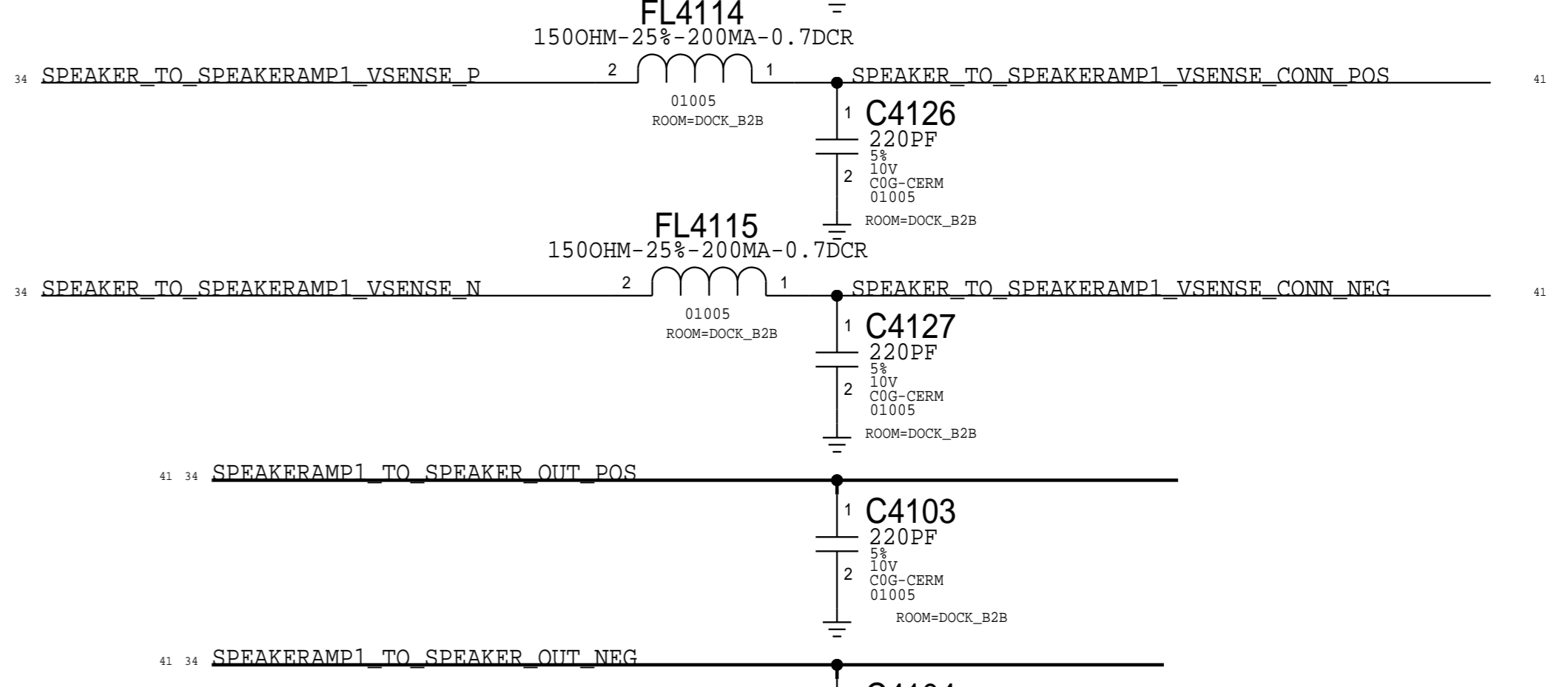

USB AC Coupling

AC return path for USB pairs which is referenced to GND and VDD_MAIN

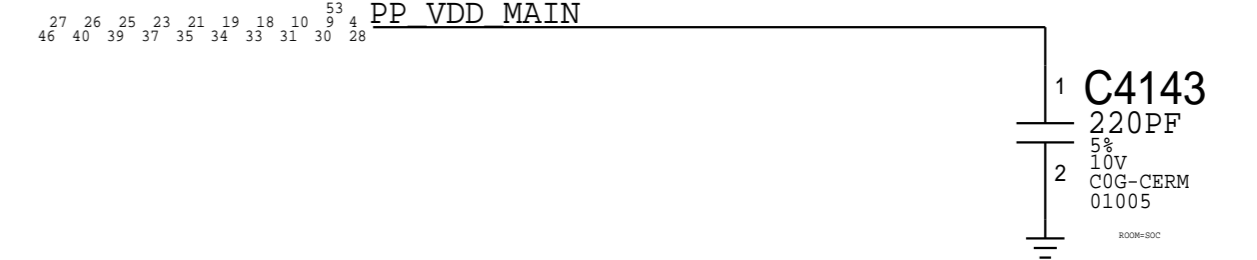

PAGE TITLE		B2B:DOCK FLEX	
DRAWING NUMBER		051-00482	SIZE D
REVISION		8.0.0	
BRANCH			
PAGE		41 OF 53	
SHEET		41 OF 81	

Apple Inc.

NOTICE OF PROPRIETARY PROPERTY:
 THE INFORMATION CONTAINED HEREIN IS THE PROPRIETARY PROPERTY OF APPLE INC. THE POSSESSOR AGREES TO THE FOLLOWING:
 I TO MAINTAIN THIS DOCUMENT IN CONFIDENCE
 II NOT TO REPRODUCE OR COPY IT
 III NOT TO REVEAL OR PUBLISH IT IN WHOLE OR PART
 IV ALL RIGHTS RESERVED

8

7

6

5

4

3

2

1

D

D

C

C

B

B

A

A

8

7

6

5

4

3

2

1

PAGE TITLE		spare	
 Apple Inc.	DRAWING NUMBER	051-00482	SIZE D
	REVISION	8.0.0	
NOTICE OF PROPRIETARY PROPERTY:		BRANCH	
THE INFORMATION CONTAINED HEREIN IS THE PROPRIETARY PROPERTY OF APPLE INC. THE POSSESSOR AGREES TO THE FOLLOWING: I TO MAINTAIN THIS DOCUMENT IN CONFIDENCE II NOT TO REPRODUCE OR COPY IT III NOT TO REVEAL OR PUBLISH IT IN WHOLE OR PART IV ALL RIGHTS RESERVED		PAGE 42 OF 53	
		SHEET 42 OF 81	

8

7

6

5

4

3

2

1

D

D

C

C

B

B

A

A

8

7

6

5

4

3

2

1

PAGE TITLE		spare	
 Apple Inc.	DRAWING NUMBER	051-00482	SIZE D
	REVISION	8.0.0	
NOTICE OF PROPRIETARY PROPERTY:		BRANCH	
THE INFORMATION CONTAINED HEREIN IS THE PROPRIETARY PROPERTY OF APPLE INC. THE POSSESSOR AGREES TO THE FOLLOWING: I TO MAINTAIN THIS DOCUMENT IN CONFIDENCE II NOT TO REPRODUCE OR COPY IT III NOT TO REVEAL OR PUBLISH IT IN WHOLE OR PART IV ALL RIGHTS RESERVED		PAGE 43 OF 53	
		SHEET 43 OF 81	

UTAH-D FLEX CONNECTOR

516S00152 RCPT (USED ON MLB) <-- THIS ONE
516S00151 PLUG

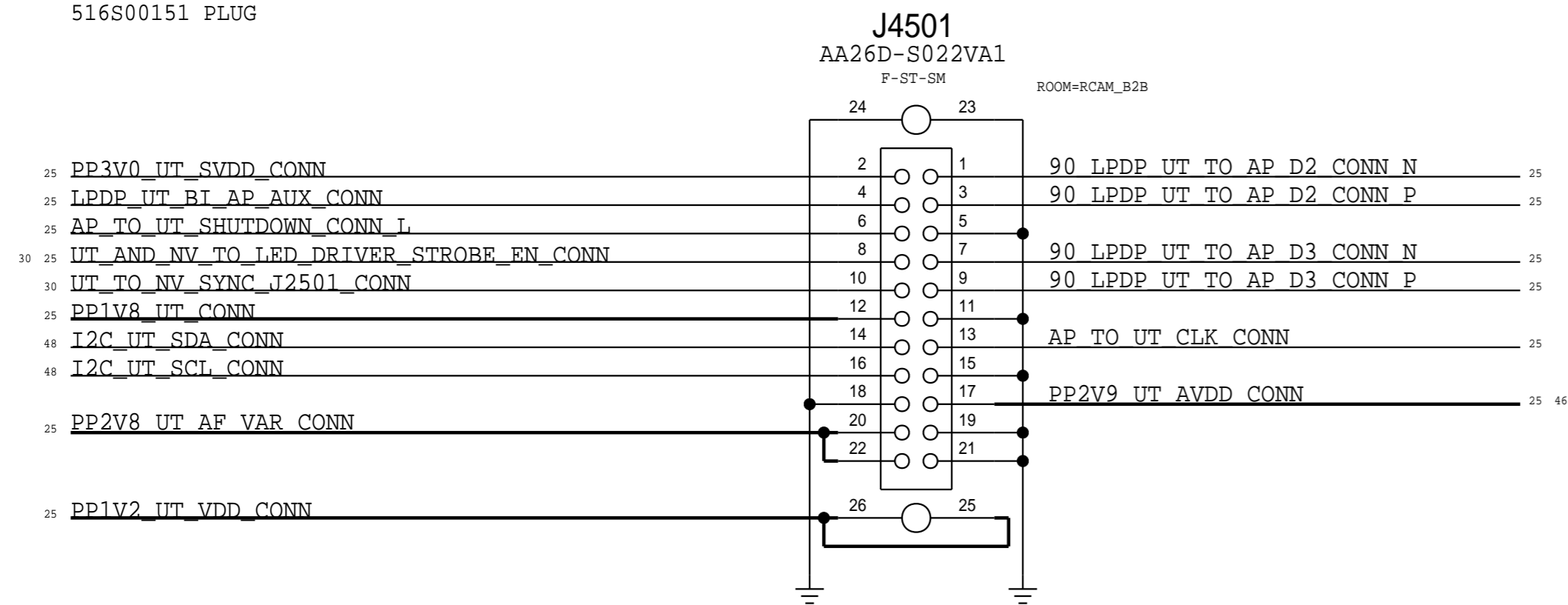

FOREHEAD FLEX CONNECTOR

MLB: 516S00146 (MCO REV 27)

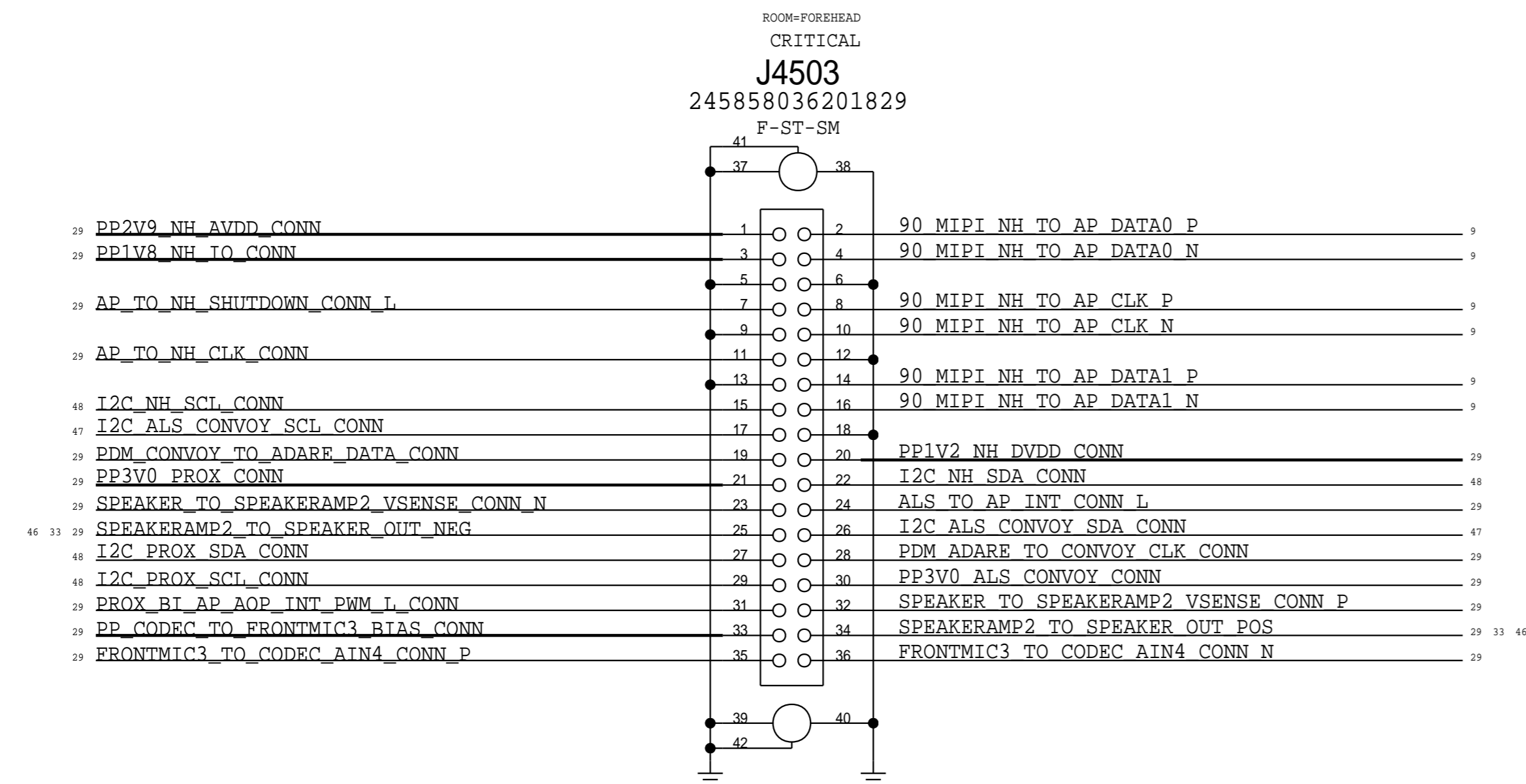

DISPLAY / TOUCH FLEX CONNECTOR

MLB: 516S00050

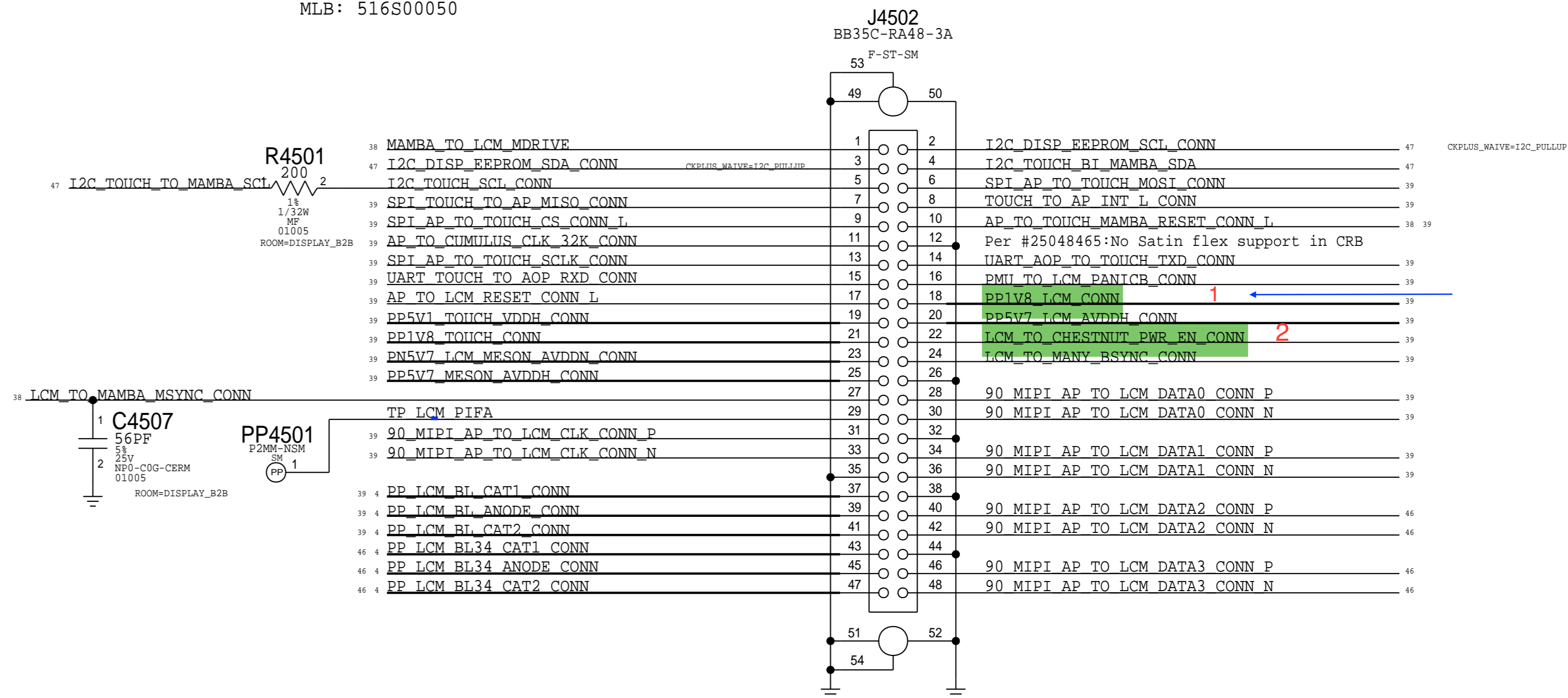

COMBO BUTTON FLEX CONNECTOR

APPLE APN: 516S00150 <-- THIS ONE ON MLB (matched MCO rev 27)
APPLE APN: 516S00149

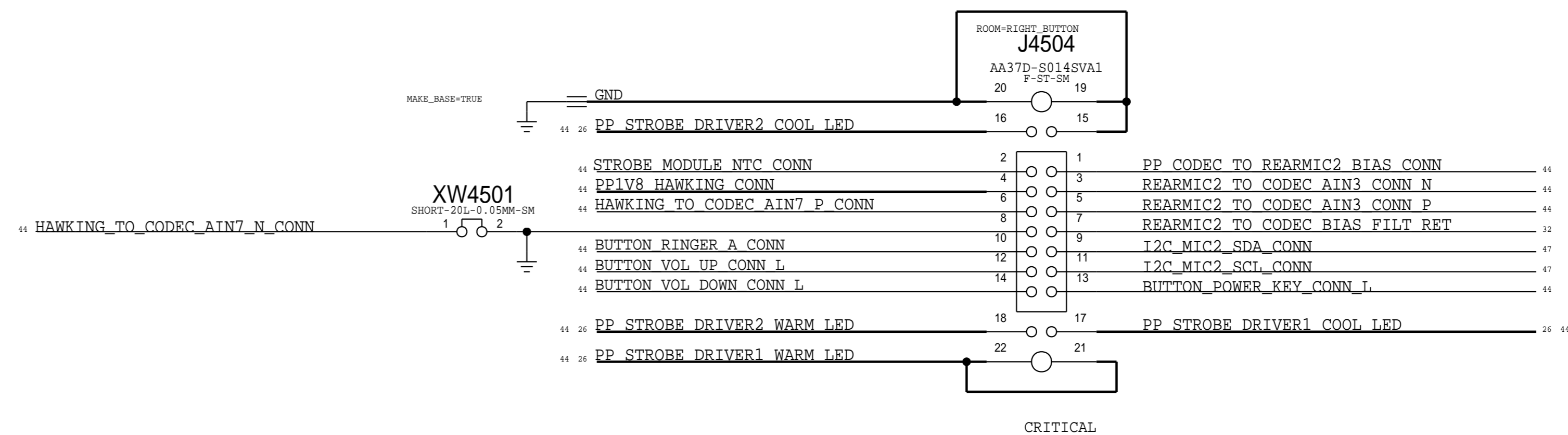

DRAWING NUMBER		051-00482	SIZE	D
REVISION		8.0.0	BRANCH	
PAGE		45 OF 53	SHEET	
SHEET		45 OF 81		

NOTICE OF PROPRIETARY PROPERTY:
THE INFORMATION CONTAINED HEREIN IS THE PROPRIETARY PROPERTY OF APPLE INC. THE POSSESSOR AGREES TO THE FOLLOWING:
I TO MAINTAIN THIS DOCUMENT IN CONFIDENCE
II NOT TO REPRODUCE OR COPY IT
III NOT TO REVEAL OR PUBLISH IT IN WHOLE OR PART
IV ALL RIGHTS RESERVED

THIS PAGE UNIQUE TO LARGE FORM FACTOR

2ND BACKLIGHT DRIVER - 4LED

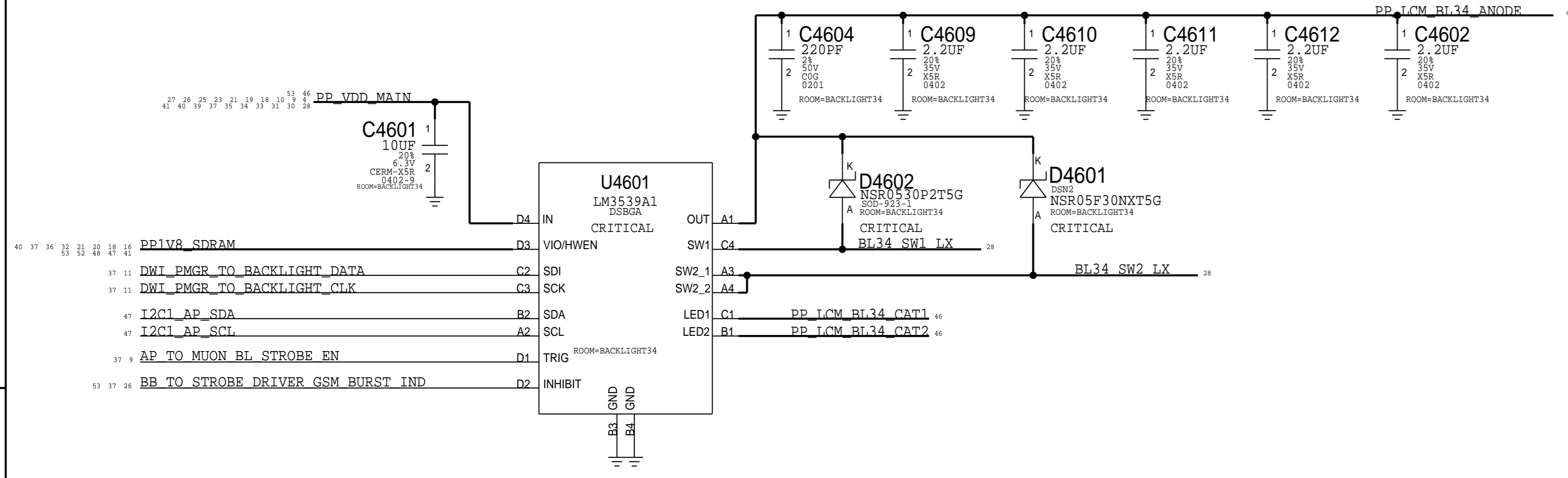

ISP I2C1

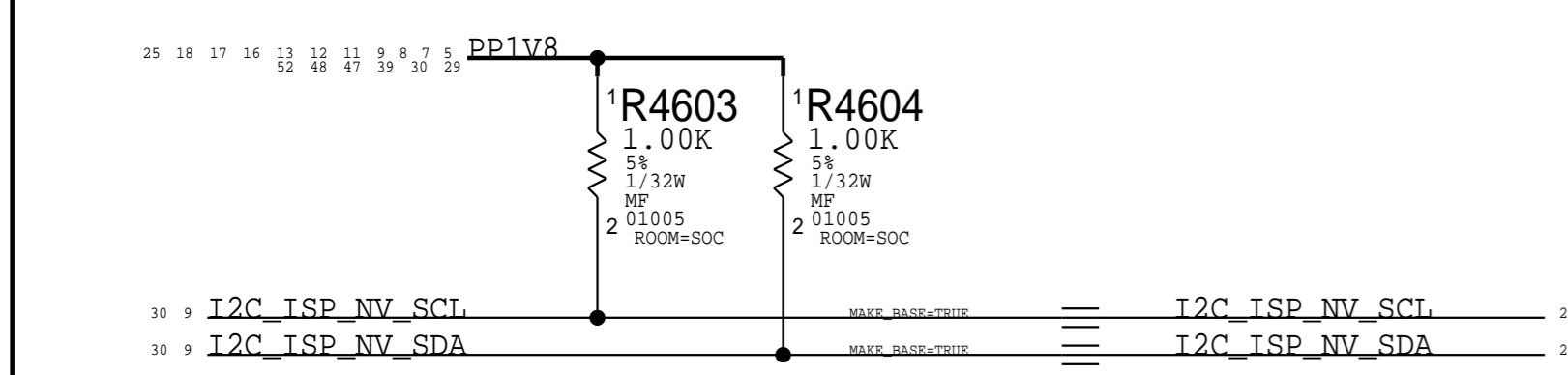

TOUCH I2C

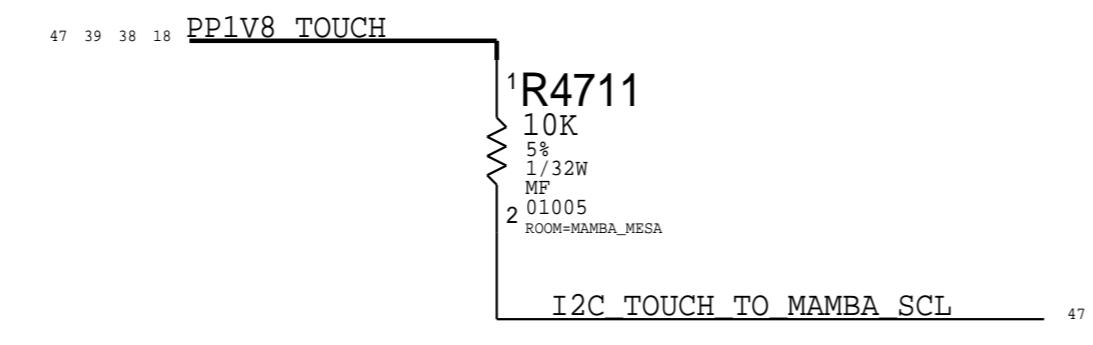

VDD MAIN CAP
AC Coupling Caps

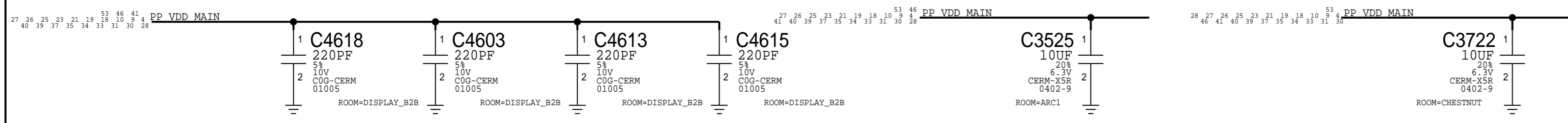

AC return path for LCM MIPI which is referenced to GND and VDD_MAIN

ACC Buck Caps

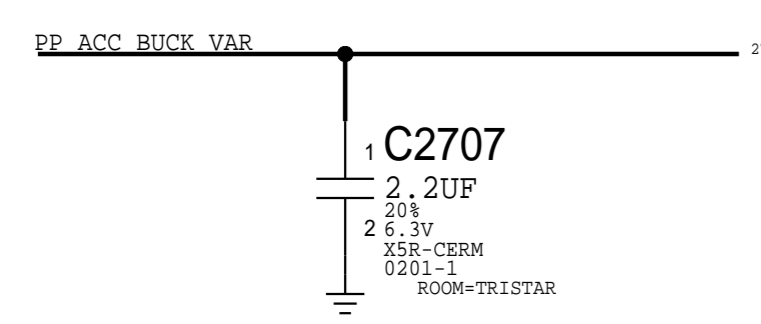

ARC CAP

CHESTNUT CAP

Top Speaker Compass Coil

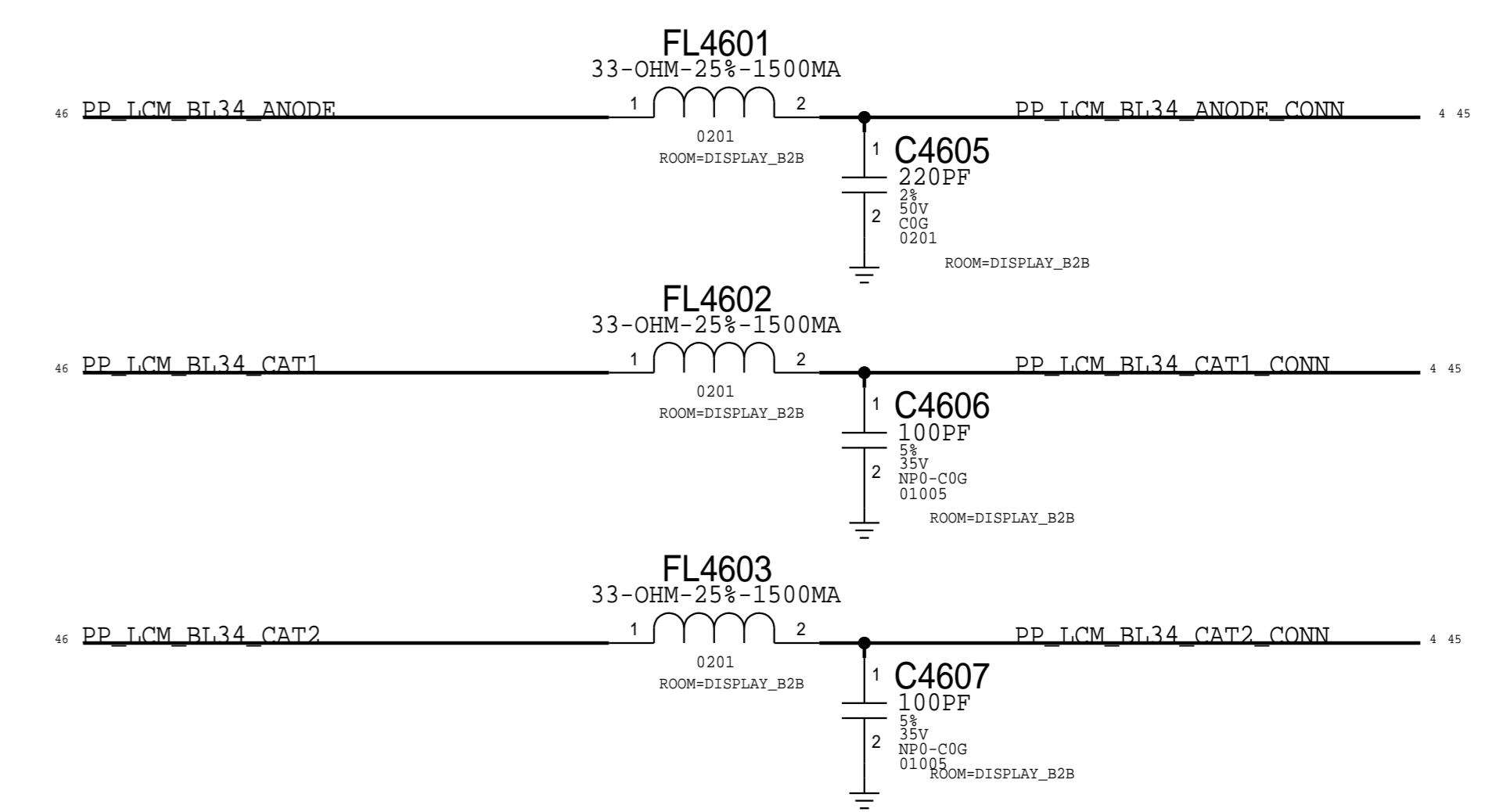
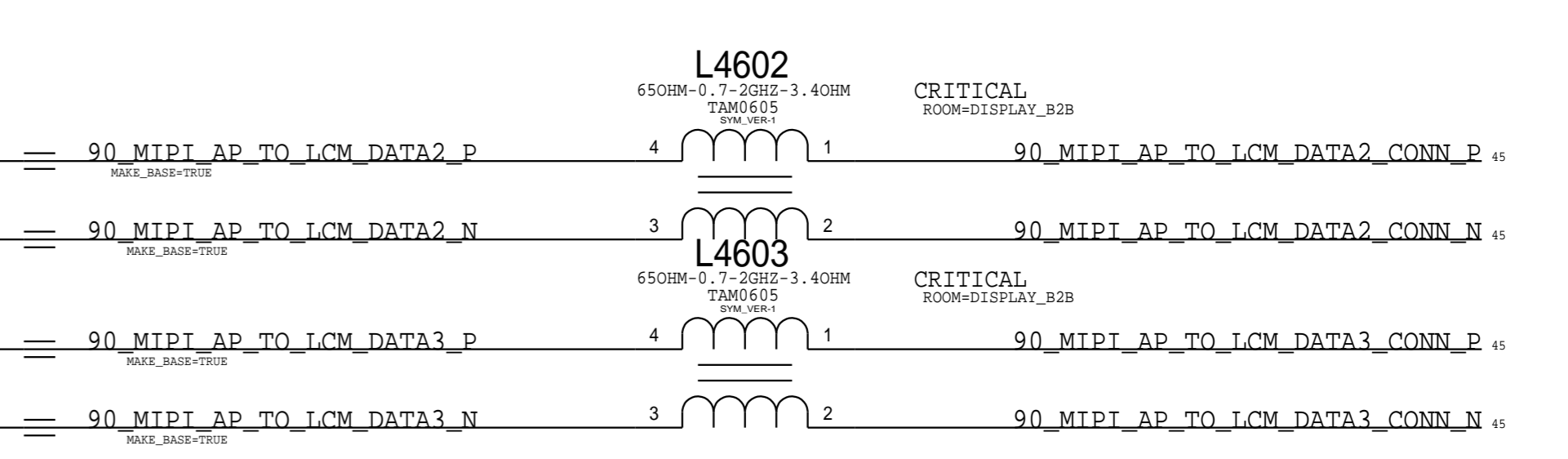
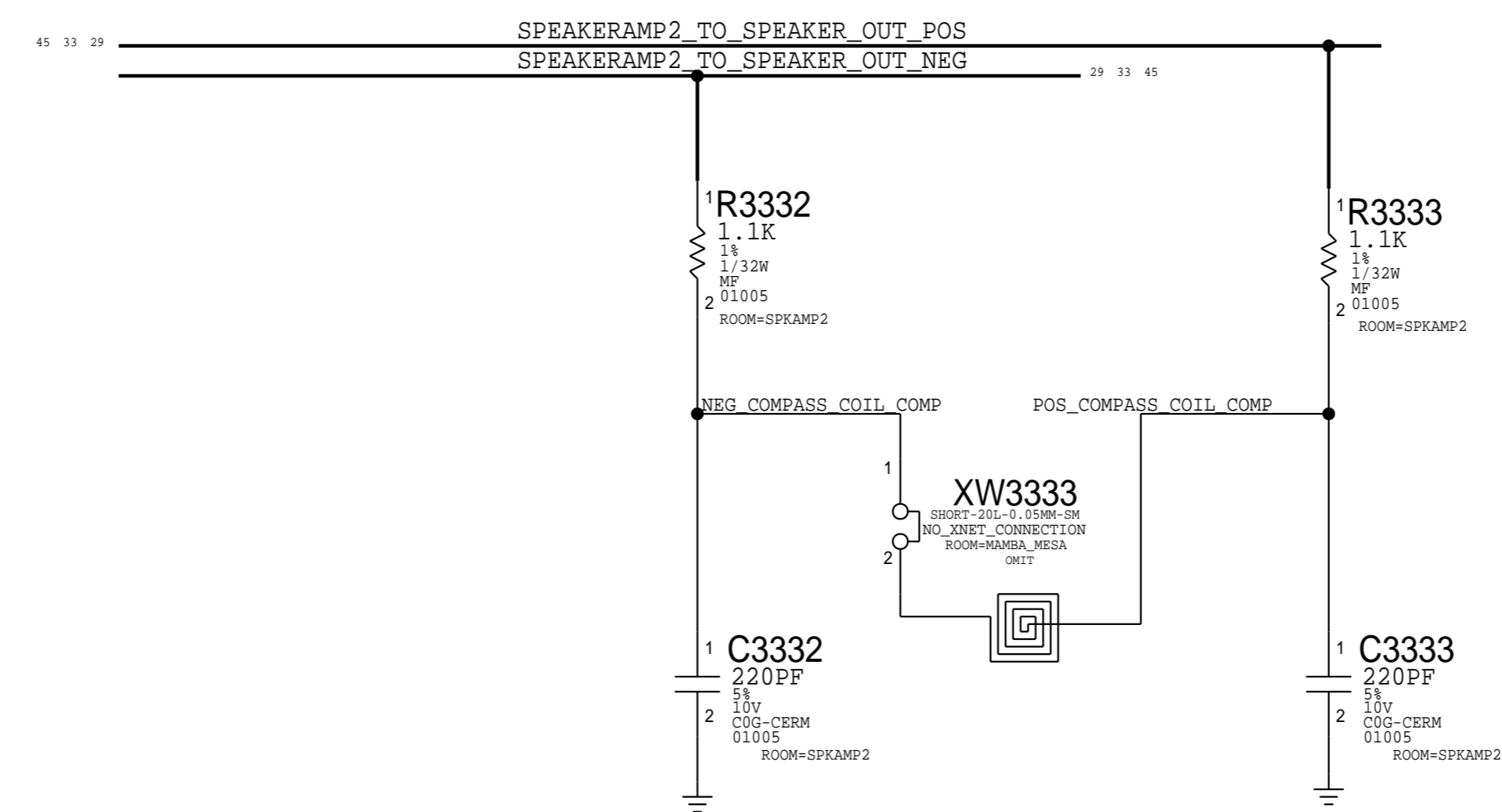

Dock B2B (Pg 41)

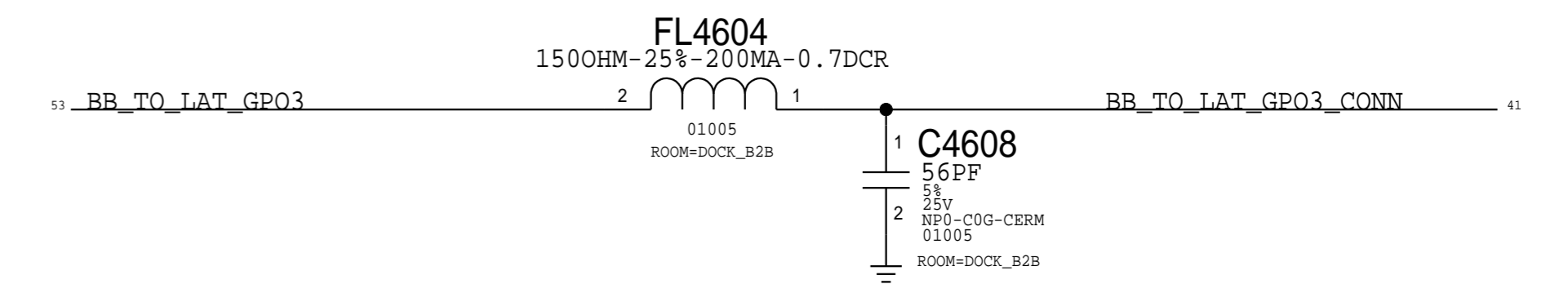

UT B2B

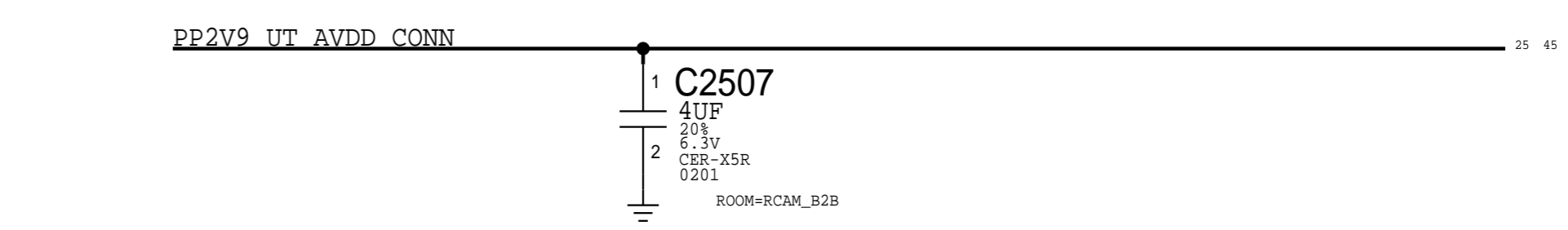

Extra RF GND

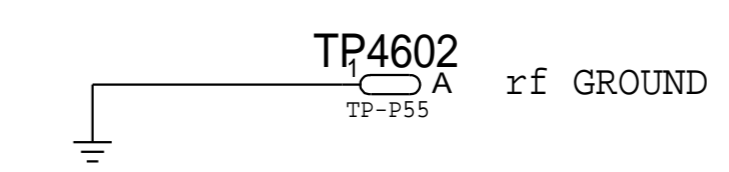

PAGE TITLE		LARGE FORM FACTOR SPECIFIC	
Apple Inc.		DRAWING NUMBER	051-00482
		REVISION	8.0.0
NOTICE OF PROPRIETARY PROPERTY:		BRANCH	
THE INFORMATION CONTAINED HEREIN IS THE PROPRIETARY PROPERTY OF APPLE INC. THE POSSESSOR AGREES TO THE FOLLOWING:		PAGE	46 OF 53
I TO MAINTAIN THIS DOCUMENT IN CONFIDENCE		SHEET	46 OF 81
II NOT TO REPRODUCE OR COPY IT			
IV ALL RIGHTS RESERVED			

AP

I2C0

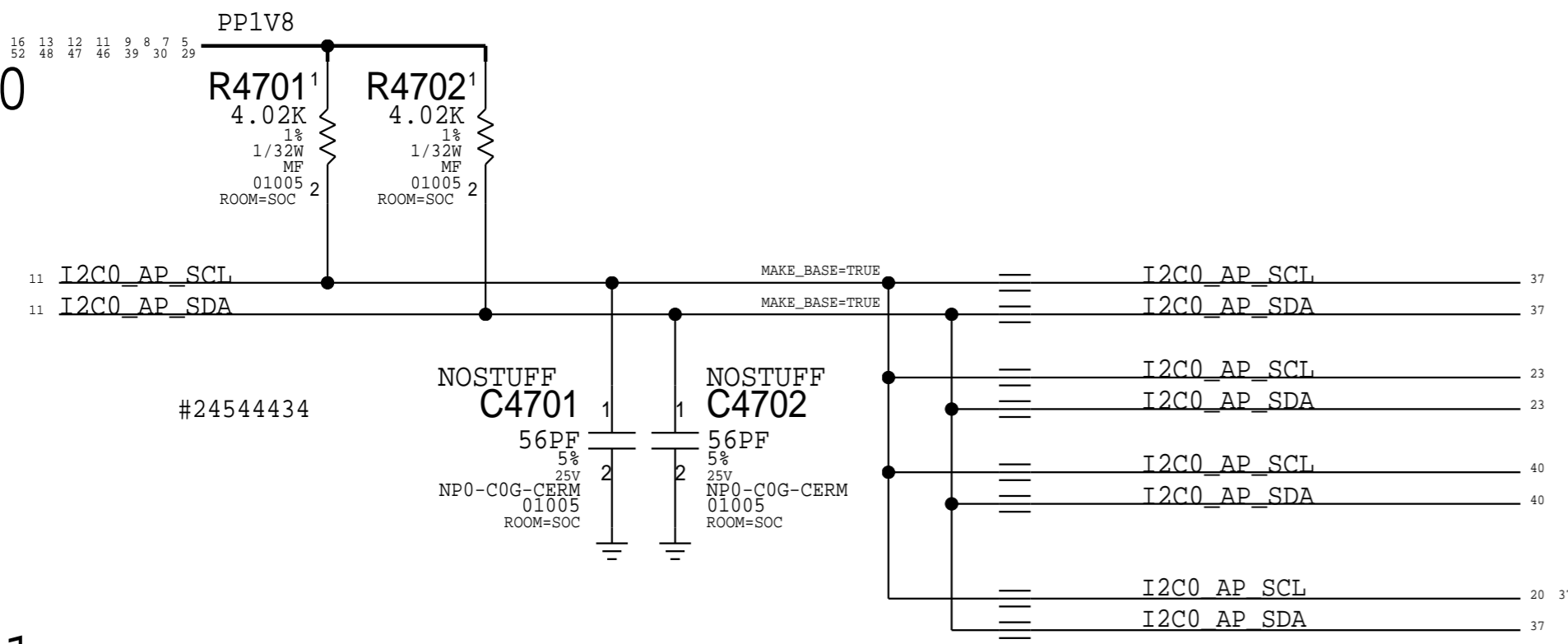

I2C1

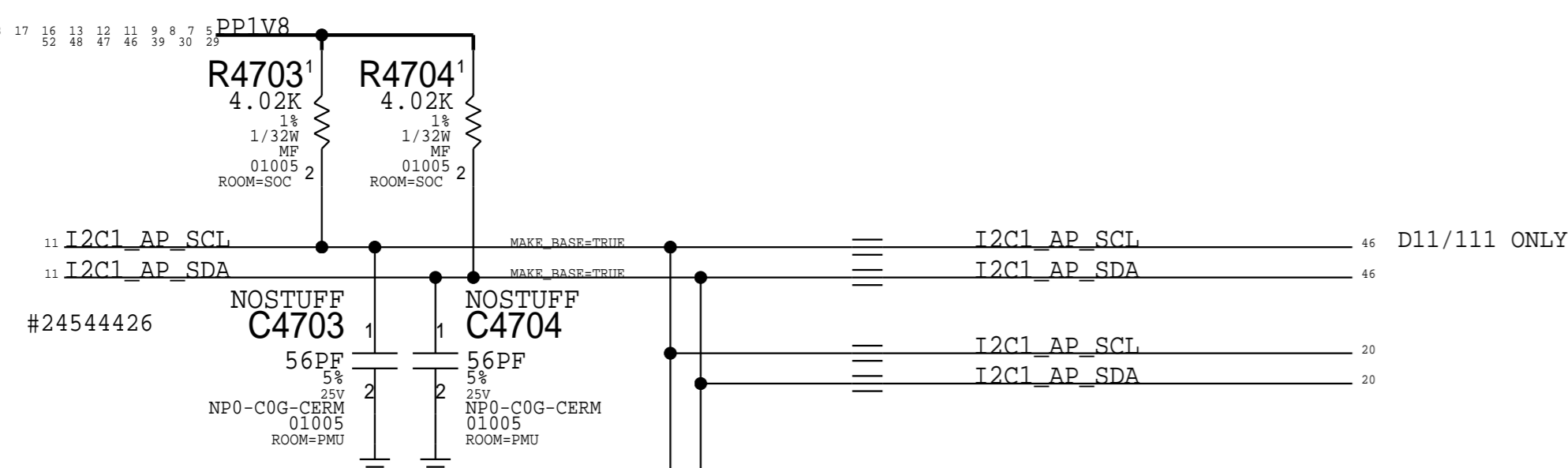

I2C2

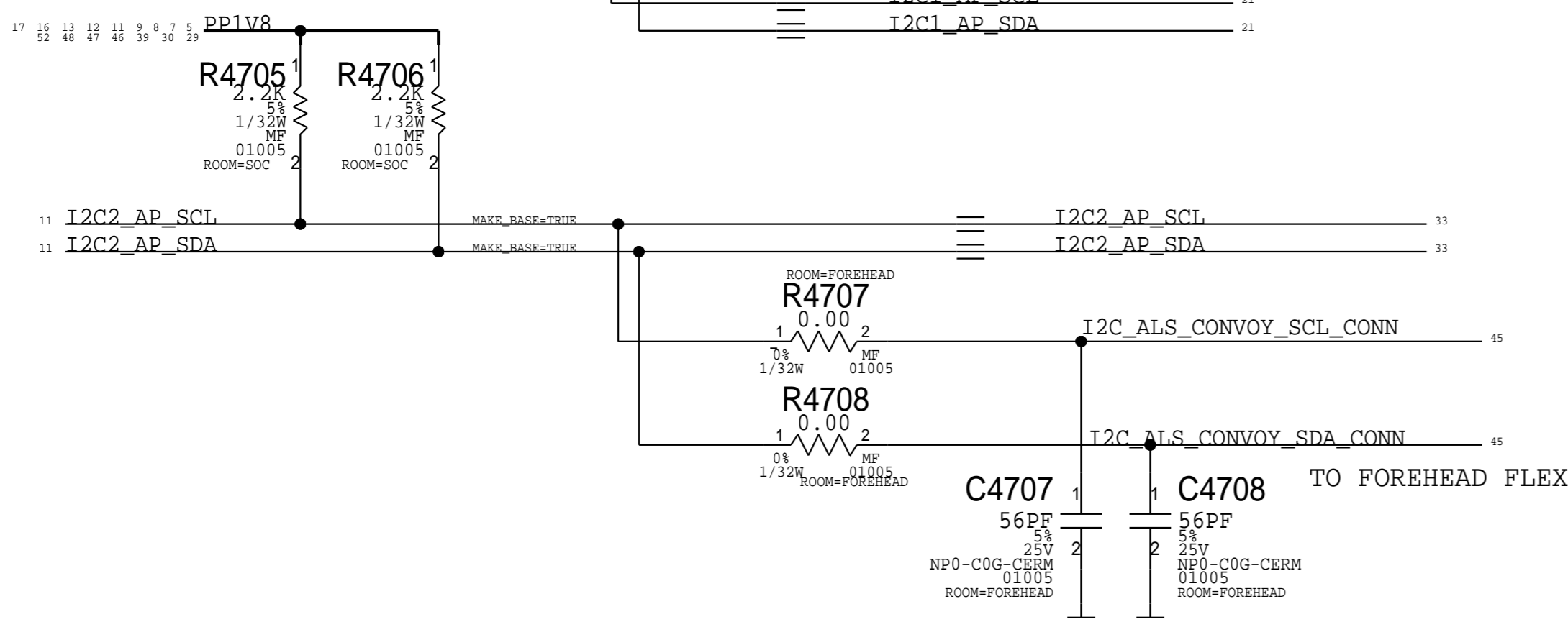

TOUCH

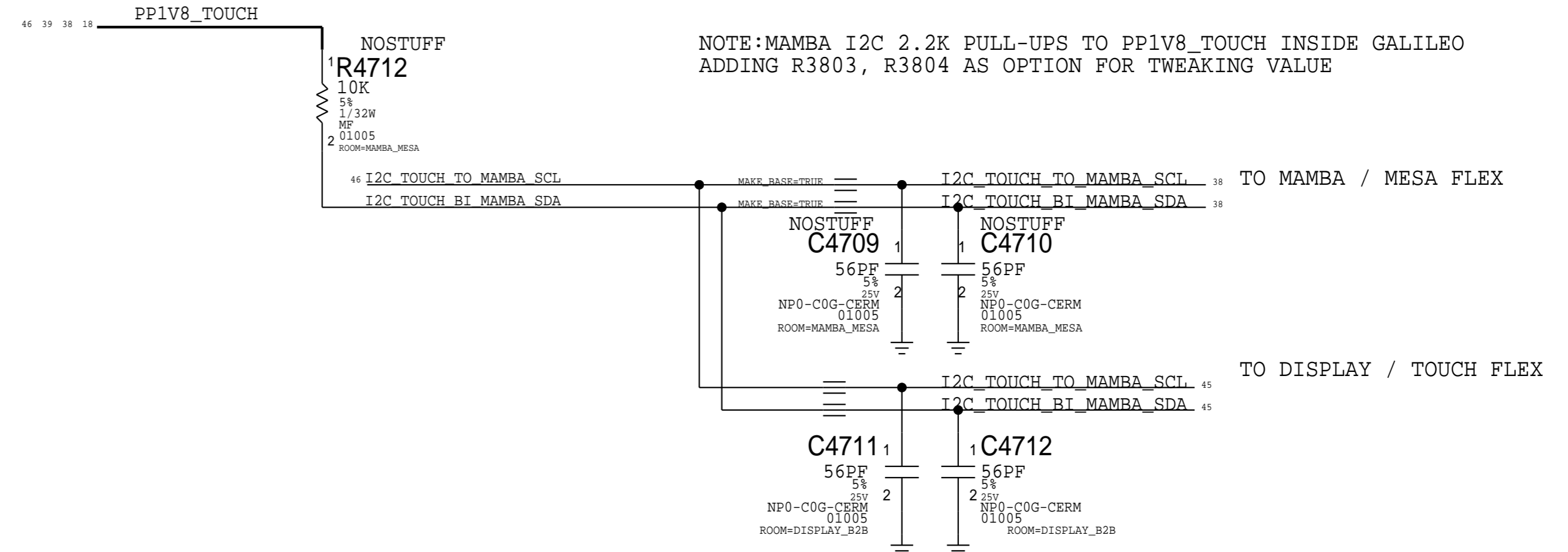

NOTE:MAMBA I2C 2.2K PULL-UPS TO PP1V8_TOUCH INSIDE GALILEO
 ADDING R3803, R3804 AS OPTION FOR TWEAKING VALUE

HOMER

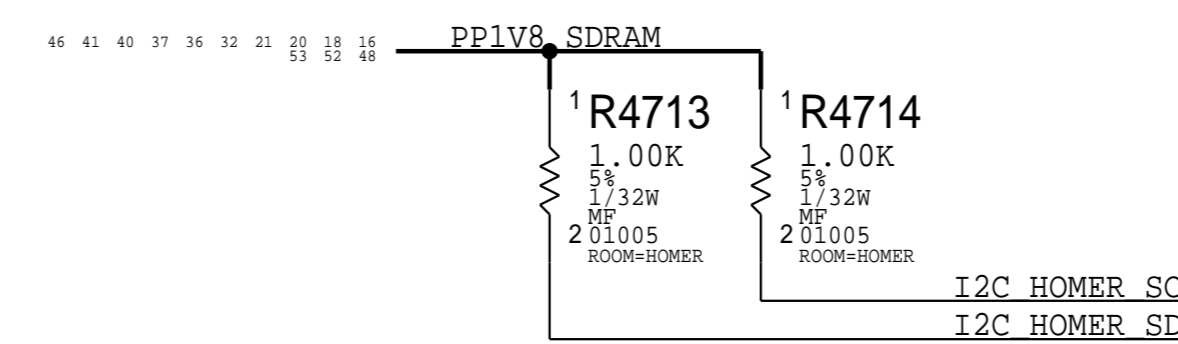

I2C5

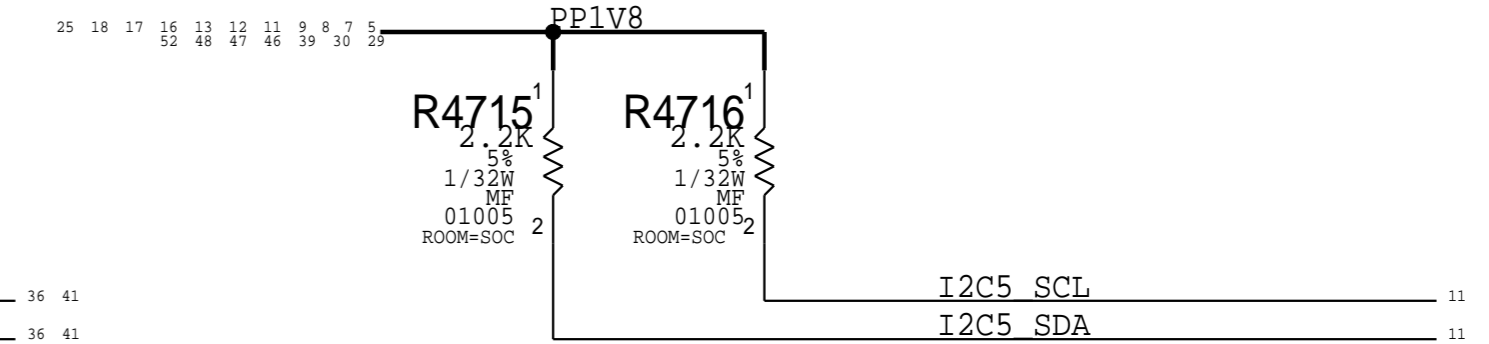

I2C3

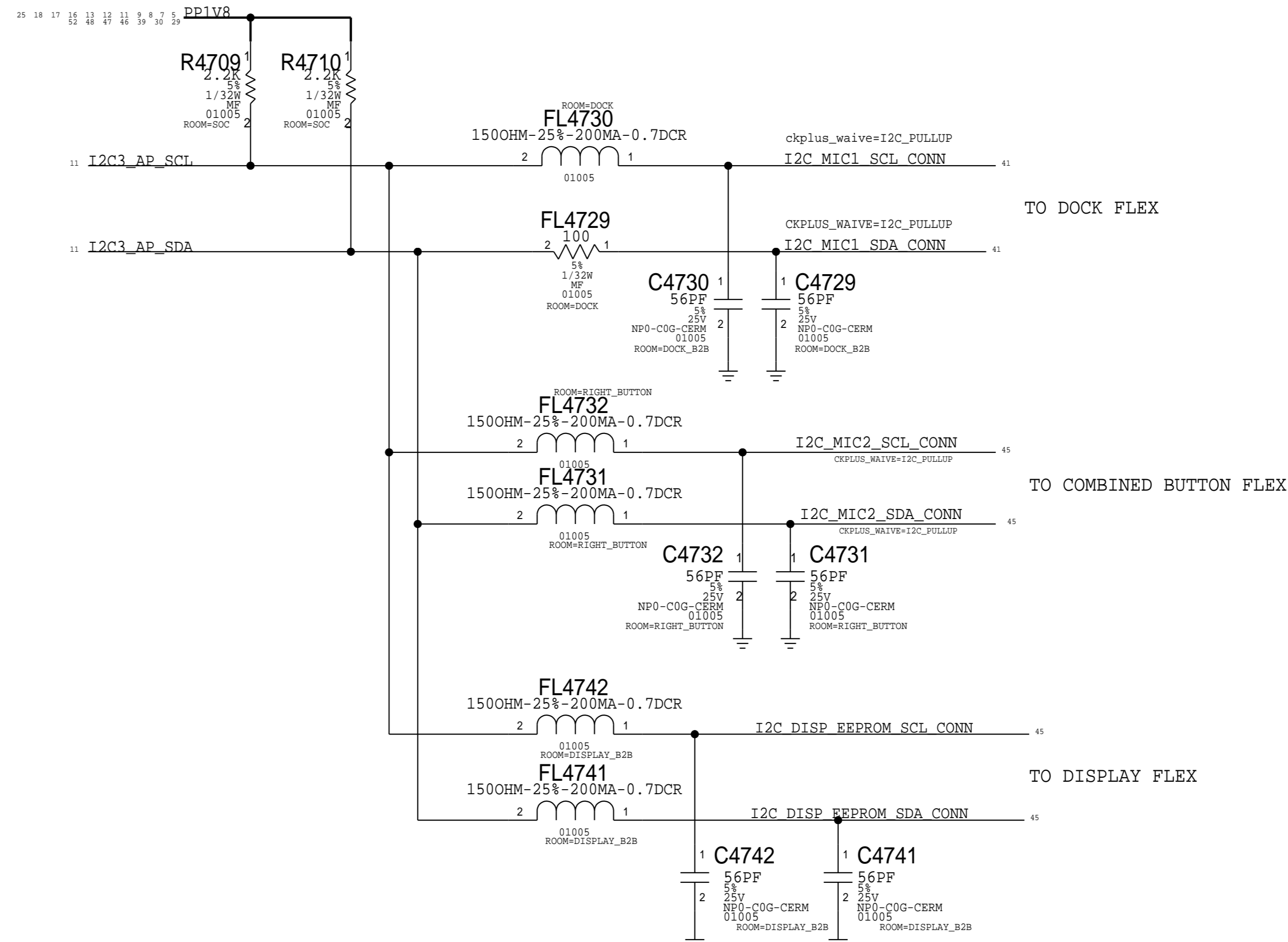

PAGE TITLE I2C MAP: AP, TOUCH, HOMER, I2C5		
Apple Inc.	DRAWING NUMBER 051-00482	SIZE D
	REVISION 8.0.0	BRANCH
NOTICE OF PROPRIETARY PROPERTY: THE INFORMATION CONTAINED HEREIN IS THE PROPRIETARY PROPERTY OF APPLE INC. THE POSSESSOR AGREES TO THE FOLLOWING: I TO MAINTAIN THIS DOCUMENT IN CONFIDENCE II NOT TO REPRODUCE OR COPY IT III NOT TO REVEAL OR PUBLISH IT IN WHOLE OR PART IV ALL RIGHTS RESERVED		
PAGE 47 OF 53	SHEET 47 OF 81	

AOP

I2C

ISP

I2C0

#24544699: Support 1MHz

#24550735: ISP I2C0 PU

D

D

C

C

B

B

A

A

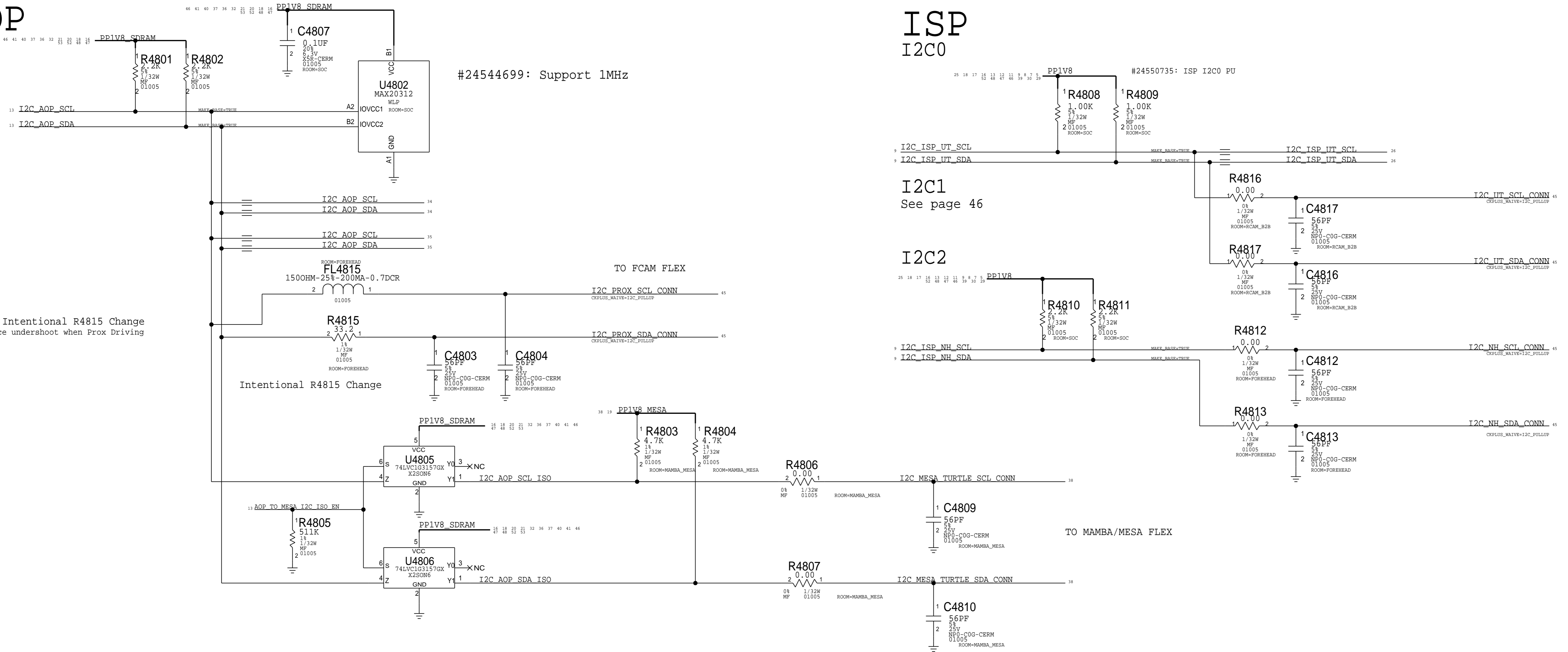

PAGE TITLE			I2C MAP AOP		
Apple Inc.		DRAWING NUMBER	051-00482	SIZE	D
		REVISION	8.0.0		
NOTICE OF PROPRIETARY PROPERTY: THE INFORMATION CONTAINED HEREIN IS THE PROPRIETARY PROPERTY OF APPLE INC. THE POSSESSOR AGREES TO THE FOLLOWING: I TO MAINTAIN THIS DOCUMENT IN CONFIDENCE II NOT TO REPRODUCE OR COPY IT III NOT TO REVEAL OR PUBLISH IT IN WHOLE OR PART IV ALL RIGHTS RESERVED		BRANCH			
		PAGE	48 OF 53		
		SHEET	48 OF 81		

D1x I2C Table

Bus	Device	Binary	7-bit Address	8-bit Address	Max Speed
ISP I2C0 <i>1MHz</i>	SALT LAKE (PRIMARY)	0010000X	0x10	0x20	1 MHz
	SALT LAKE (SECONDARY)	0110000X	0x30	0x60	1 MHz
	GRUNBERG (STANDARD)	0011100X	0x1C	0x38	1 MHz
	GRUNBERG (SPECIAL ABSOLUTE R/W)	0011101X	0x1D	0x3A	1 MHz
	GRUNBERG (SPECIAL DELTA READ)	0011110X	0x1E	0x3C	1 MHz
	STROBE 1	1100011X	0x63	0xC6	1 MHz
ISP I2C1 <i>1MHz</i>	LAS VEGAS (PRIMARY)	0100000X	0x20	0x40	1 MHz
	LAS VEGAS (SECONDARY)	0110000X	0x30	0x60	1 MHz
	EDWIN	1100011X	0x63	0xC6	400 kHz
	STROBE 2	0000110X	0x06	0x0C	1 MHz
ISP I2C2 <i>400kHz</i>	CONCORD	0010000X	0x10	0x20	1 MHz
AOP I2C <i>1MHz</i>	ARC DRIVER 1	100000YX	0x41	0x82	1 MHz
	PROX	1011000X	0x58	0xB0	1 MHz
	SPKAMP1 (L26)	100000YX	0x40	0x80	1 MHz
	TURTLE	0101100X	0x2c	0x58	400 kHz
	MESA	1100001X	0x61	0xC2	400 kHz
Touch I2C <i>600kHz</i>	MAMBA	1100000X	0x60	0xC0	1 MHz
	MESON	1000000X	0x40	0x80	510 kHz
EEPROM I2C	EEPROM	1010001X	0x51	0xA2	400 kHz
AP I2C0 <i>400kHz</i>	BOOST	1110101X	0x75	0xEA	3.4 MHz
	TRISTAR	0011010X	0x1A	0x34	400 kHz
	BACKLIGHT 1	1100010X	0x62	0xC4	1 MHz
	CHESTNUT	0100111X	0x27	0x4E	400 kHz
AP I2C1 <i>400kHz</i>	ADELYN	1110100X	0x74	0xE8	400 kHz
	TIGRIS	1110101X	0x75	0xEA	400 kHz
	BACKLIGHT 2	1100010X	0x62	0xC4	1 MHz
AP I2C2 <i>400kHz</i>	ALS	0101001X	0x29	0x52	400 kHz
	CONVOY	0100001X	0x21	0x42	3.4 MHz
		0100010X	0x22	0x44	400 kHz
SPKAMP 2 (L26)	10000ZYX	0x40	0x80	400 MHz	
AP I2C3 <i>100kHz</i>	DOCK FLEX (MIC1)	1010100X	0x54	0xA8	1 MHz
	COMBINED BUTTON FLEX (MIC2)	1010100X	0x56	0xAC	1 MHz
	DISP EEPROM	1010001X	0x51	0xA2	400kHz
Homer I2C <i>1MHz</i>	SCHRODINGER (STANDARD)	0001110X	0xE	0x1C	1 MHz
	SCHRODINGER (CAL REG'S)	0001111X	0xF	0x1D	1 MHz
	EEPROM (STANDARD)	1010000X	0x50	0xA0	
	EEPROM (CONFIG)	1010000X	0x50	0xA0	

PAGE TITLE		I2C TABLE	
 Apple Inc.	DRAWING NUMBER	051-00482	SIZE D
	REVISION	8.0.0	
NOTICE OF PROPRIETARY PROPERTY:		BRANCH	
THE INFORMATION CONTAINED HEREIN IS THE PROPRIETARY PROPERTY OF APPLE INC. THE POSSESSOR AGREES TO THE FOLLOWING: I TO MAINTAIN THIS DOCUMENT IN CONFIDENCE II NOT TO REPRODUCE OR COPY IT III NOT TO REVEAL OR PUBLISH IT IN WHOLE OR PART IV ALL RIGHTS RESERVED		PAGE	49 OF 53
		SHEET	49 OF 81

spare

spare

This page controls elements different accross all MLBs PCIe Lanes

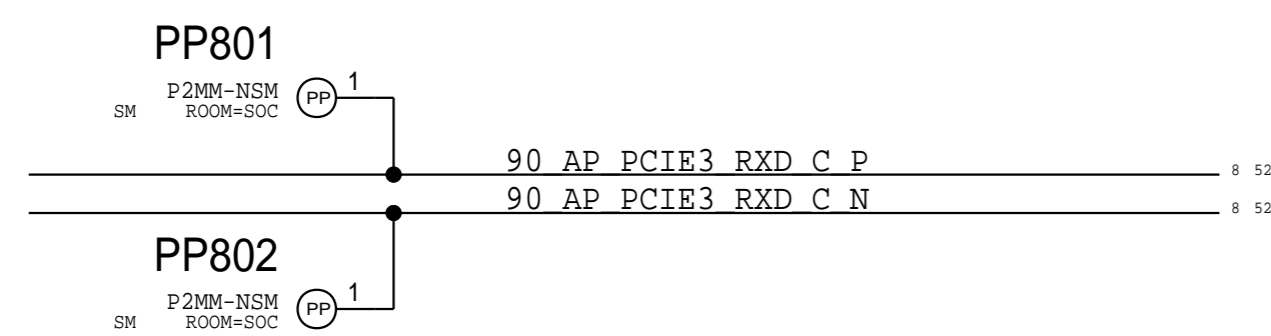

8	90 AP PCIe2 RXD C P	C0816	1 2	0.1UF	90 PCIe BB TO AP_RXD P	53	MAKE_BASE=TRUE
8	90 AP PCIe2 RXD C N	C0817	1 2	0.1UF	90 PCIe BB TO AP_RXD N	53	MAKE_BASE=TRUE
8	90 AP PCIe2 TXD C P	C0815	1 2	0.1UF	90 PCIe AP TO BB_TXD P	53	MAKE_BASE=TRUE
8	90 AP PCIe2 TXD C N	C0818	1 2	0.1UF	90 PCIe AP TO BB_TXD N	53	MAKE_BASE=TRUE
52	90 AP PCIe3 RXD C P	C0811	1 2	0.1UF	90 PCIe WLAN TO AP_RXD P	53	MAKE_BASE=TRUE
52	90 AP PCIe3 RXD C N	C0812	1 2	0.1UF	90 PCIe WLAN TO AP_RXD N	53	MAKE_BASE=TRUE
8	90 AP PCIe3 TXD C P	C0814	1 2	0.1UF	90 PCIe AP TO WLAN_TXD P	53	MAKE_BASE=TRUE
8	90 AP PCIe3 TXD C N	C0813	1 2	0.1UF	90 PCIe AP TO WLAN_TXD N	53	MAKE_BASE=TRUE
8	90 PCIe AP TO WLAN_REPCLK P				90 PCIe AP TO WLAN_REPCLK P	53	MAKE_BASE=TRUE
8	90 PCIe AP TO WLAN_REPCLK N				90 PCIe AP TO WLAN_REPCLK N	53	MAKE_BASE=TRUE
8	90 PCIe AP TO BB_REPCLK P				90 PCIe AP TO BB_REPCLK P	53	MAKE_BASE=TRUE
8	90 PCIe AP TO BB_REPCLK N				90 PCIe AP TO BB_REPCLK N	53	MAKE_BASE=TRUE
8	PCIe AP TO WLAN_RESET L				PCIe AP TO WLAN_RESET L	53	MAKE_BASE=TRUE
8	PCIe AP TO BB_RESET L				PCIe AP TO BB_RESET L	53	MAKE_BASE=TRUE
8	PCIe WLAN BI AP_CLKREQ L				PCIe WLAN BI AP_CLKREQ L	53	MAKE_BASE=TRUE
8	PCIe BB BI AP_CLKREQ L				PCIe BB BI AP_CLKREQ L	53	MAKE_BASE=TRUE

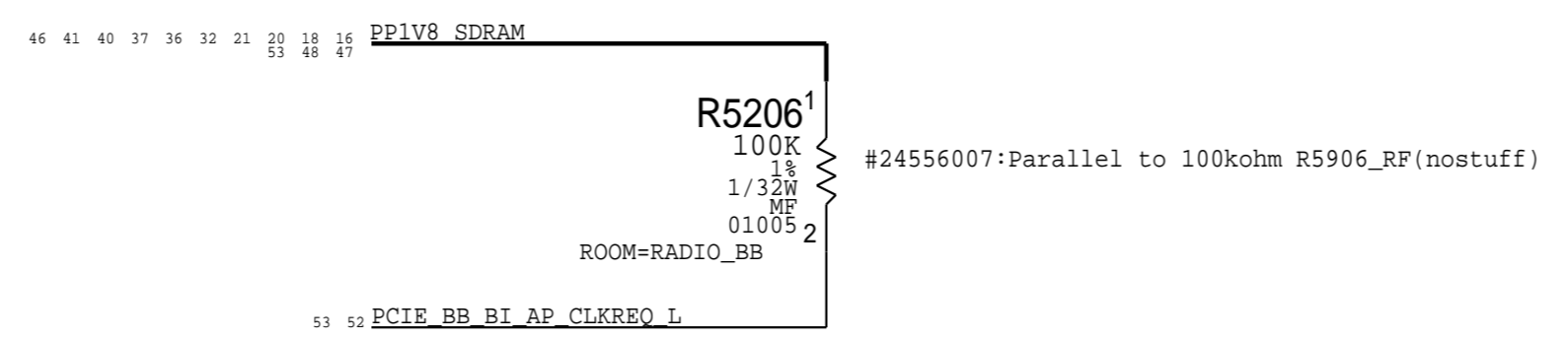
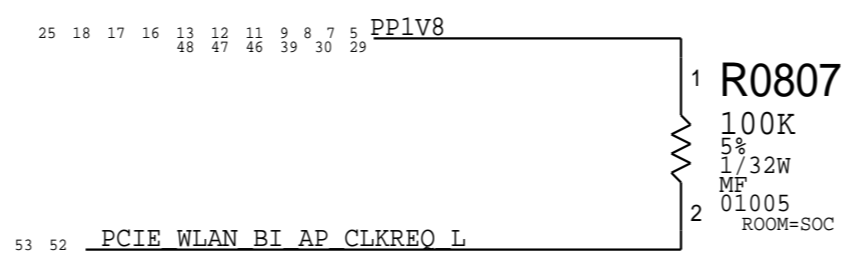

SYNC_MASTER=david-copy		SYNC_DATE=03/01/2016	
PAGE TITLE			
MLB UNIQUE			
	DRAWING NUMBER	051-00482	SIZE D
	REVISION	8.0.0	
NOTICE OF PROPRIETARY PROPERTY: THE INFORMATION CONTAINED HEREIN IS THE PROPRIETARY PROPERTY OF APPLE INC. THE POSSESSOR AGREES TO THE FOLLOWING: I TO MAINTAIN THIS DOCUMENT IN CONFIDENCE II NOT TO REPRODUCE OR COPY IT III NOT TO REVEAL OR PUBLISH IT IN WHOLE OR PART IV ALL RIGHTS RESERVED		BRANCH	
		PAGE	52 OF 53
		SHEET	52 OF 81

Cellular

Wifi/BT

46 41 40 39 38 37 36 35 34 33 32 31 30 29 28 27 26 25 24 23 22 21 20 19 18 17 16 15 14 13 12 11 10 9 8 7 6 5 4	PP_VDD_MAIN PP1V8_SDRAM	PP_VDD_MAIN PP1V8_SDRAM
60 20	PMUGPIO_TO_WLAN_CLK32K	PMU_TO_WLAN_32K
60 20	PMU_TO_WLAN_REG_ON	PMU_TO_WLAN_REG_ON
60 20	PMU_TO_BT_REG_ON	PMU_TO_BT_REG_ON
60 20	BT_TO_PMU_HOST_WAKE	BT_TO_PMU_HOST_WAKE
60 12	AP_TO_BT_WAKE	AP_TO_BT_WAKE
60 52	90_PCIE_AP_TO_WLAN_REFCLK_P	100_PCIE_AP_TO_WLAN_REFCLK_P
60 52	90_PCIE_AP_TO_WLAN_REFCLK_N	100_PCIE_AP_TO_WLAN_REFCLK_N
60 52	90_PCIE_AP_TO_WLAN_TXD_P	100_PCIE_AP_TO_WLAN_TX_P
60 52	90_PCIE_AP_TO_WLAN_TXD_N	100_PCIE_AP_TO_WLAN_TX_N
60 52	90_PCIE_WLAN_TO_AP_RXD_P	100_PCIE_WLAN_TO_AP_RX_P
60 52	90_PCIE_WLAN_TO_AP_RXD_N	100_PCIE_WLAN_TO_AP_RX_N
60 52	PCIE_AP_TO_WLAN_RESET_I	PCIE_AP_TO_WLAN_PERST_L
60 52	PCIE_WLAN_BT_AP_CLKREQ_I	PCIE_AP_BI_WLAN_CLKREQ_L
60 20	WLAN_TO_PMU_HOST_WAKE	PCIE_WLAN_TO_PMU_WAKE
60 12	AP_TO_WLAN_DEVICE_WAKE	AP_TO_WLAN_DEV_WAKE
60 12	IUART_AP_TO_WLAN_TXD	UART_AP_TO_WLAN_TXD
60 12	IUART_WLAN_TO_AP_RXD	UART_WLAN_TO_AP_RXD
60 12	IUART_AP_TO_WLAN_RTS_I	UART_AP_TO_WLAN_RTS_L
60 12	IUART_WLAN_TO_AP_CTS_I	UART_WLAN_TO_AP_CTS_L
60 12	IUART_AP_TO_BT_TXD	UART_AP_TO_BT_TXD
60 12	IUART_BT_TO_AP_RXD	UART_BT_TO_AP_RXD
60 12	IUART_AP_TO_BT_RTS_I	UART_AP_TO_BT_RTS_L
60 12	IUART_BT_TO_AP_CTS_I	UART_BT_TO_AP_CTS_L
60 12	AOP_TO_WLAN_CONTEXT_A	AOP_TO_WLAN_CONTEXT_A
60 12	AOP_TO_WLAN_CONTEXT_B	AOP_TO_WLAN_CONTEXT_B
60 11	I2S_AP_TO_BT_BCLK	I2S_AP_TO_BT_BCLK
60 11	I2S_AP_TO_BT_LRCLK	I2S_AP_TO_BT_LRCLK
60 11	I2S_BT_TO_AP_DIN	I2S_BT_TO_AP_DIN
60 11	I2S_AP_TO_BT_DOUT	I2S_AP_TO_BT_DOUT
60 53	IUART_BB_TO_WLAN_COEX	UART_BB_TO_WLAN_COEX
60 53	IUART_WLAN_TO_BB_COEX	UART_WLAN_TO_BB_COEX
61 57 53	50_UAT_WLAN_5G_WEST	50_UAT_WLAN_5G_WEST
61 57 53	50_UAT_WLAN_2G_EAST	50_UAT_WLAN_2G_EAST
61 57 53	50_UAT_WLAN_5G_EAST	50_UAT_WLAN_5G_EAST
60 57 53	50_WLAN_G_1	50_WLAN_G_1
60 57 53	50_WLAN_A_1	50_WLAN_A_1
61 58 53	50_UAT2_M	50_UAT2_M

WIFI_MLB

Opposite polarity on Karoo -->

46 41 40 39 38 37 36 35 34 33 32 31 30 29 28 27 26 25 24 23 22 21 20 19 18 17 16 15 14 13 12 11 10 9 8 7 6 5 4	PP_VDD_MAIN PP1V8_SDRAM	PP_VDD_MAIN PP1V8_SDRAM
65 38 37 32 30 25 23 19	PP_VDD_BOOST BBPMU_TO_PMU_AMUX1 BBPMU_TO_PMU_AMUX2 BBPMU_TO_PMU_AMUX3	PP_VDD_BOOST_RF BBPMU_TO_PMU_AMUX1 BBPMU_TO_PMU_AMUX2 BBPMU_TO_PMU_AMUX3
		NCX
64 12	AP_TO_BBPMU_RADIO_ON_I	AP_TO_BBPMU_RADIO_ON_L
64 20	PMU_TO_BBPMU_RESET_I	PMU_TO_BBPMU_RESET_L
64 12	AP_TO_BB_RESET_I	AP_TO_BB_RESET_L
68 12	BB_TO_AP_RESET_DETECT_I	BB_TO_AP_RESET_DETECT_L
68 37 26	BB_TO_STROBE_DRIVER_GSM_BURST_IND	BB_TO_AP_GSM_TXBURST
68 12	AP_TO_BB_MESA_ON	AP_TO_BB_GYRO_FORCE_PWM
68 12	AP_TO_BB_TIME_MARK	AP_TO_BB_TIME_MARK
68 12	AP_TO_BB_COREDUMP	AP_TO_BB_COREDUMP_TRIG
64 39 23 20	LCM_TO_MANY_BSYNCP AP_TO_BB_IPC_GPIO1	TOUCH_TO_BBPMU_FORCE_PWM AP_TO_BB_MESA_ON AP_TO_BB_IPC_GPIO2
67 52	90_PCIE_AP_TO_BB_REFCLK_P	100_PCIE_AP_TO_BB_REFCLK_P
67 52	90_PCIE_AP_TO_BB_REFCLK_N	100_PCIE_AP_TO_BB_REFCLK_N
67 52	90_PCIE_AP_TO_BB_TXD_P	100_PCIE_AP_TO_BB_TX_P
67 52	90_PCIE_AP_TO_BB_TXD_N	100_PCIE_AP_TO_BB_TX_N
67 52	90_PCIE_BB_TO_AP_RXD_P	100_PCIE_BB_TO_AP_RX_P
67 52	90_PCIE_BB_TO_AP_RXD_N	100_PCIE_BB_TO_AP_RX_N
68 52	PCIE_AP_TO_BB_RESET_I	PCIE_AP_TO_BB_PERST_L
68 52	PCIE_BB_BT_AP_CLKREQ_I	PCIE_AP_BI_BB_CLKREQ_L
68 20	BB_TO_PMU_PCIE_HOST_WAKE_I	PCIE_BB_TO_PMU_WAKE_L
68 13	IUART_AOP_TO_BB_TXD	UART_AP_TO_BB_TXD UART_BB_TO_AP_RXD
68 13	IUART_BB_TO_AOP_RXD	UART_BB_TO_AOP_RXD UART_AOP_TO_GNSS_TXD UART_GNSS_TO_AOP_RXD
68 11	I2S_BB_TO_AP_BCLK	I2S_AP_TO_BB_BCLK
68 11	I2S_BB_TO_AP_LRCLK	I2S_AP_TO_BB_LRCLK
68 11	I2S_AP_TO_BB_DOUT	I2S_AP_TO_BB_DOUT
68 11	I2S_BB_TO_AP_DIN	I2S_BB_TO_AP_DIN
68 60 53	IUART_BB_TO_WLAN_COEX	UART_BB_TO_WLAN_COEX
68 60 53	IUART_WLAN_TO_BB_COEX	UART_WLAN_TO_BB_COEX
81 55 53	NFC_SWP	NFC_SWP
64 55 53	NFC_TO_BB_CLK_REQ	NFC_TO_BB_CLKREQ
64 55 53	BB_TO_NFC_CLK	BB_TO_NFC_CLK
78 55 53	NFC_SWP_MUX	NFC_SWP_MUX
78 55 53	SE2_READY	SE2_READY
78 55 53	AP_TO_ICEFALL_FW_DWLD_REQ	AP_TO_ICEFALL_FW_DWLD MAKE_BASE=TRUE
78 55 53	SE2_PWR_REQ	SE2_PWR_REQ
81 55 53	SE2_PRESENT	SE2_PRESENT
78 55 53	ICEFALL_LDO_ENABLE	ICEFALL_LDO_ENABLE
67 36 17 13	SWD_AP_TO_MANY_SWCLK SWD_AOP_BT_BB_SWDIO PMU_TO_BB_USB_VBUS_DETECT 90_USB_BB_DATA_P 90_USB_BB_DATA_N	SWD_AP_TO_BB_CLK SWD_AP_BI_BB_IO USB_BB_VBUS 90_USB_BB_P 90_USB_BB_N
76 57 53	50_UAT_WLAN_2G_WEST_PLEXER	50_UAT_WLAN_2G_WEST_PLEXER
73 57 53	50_UAT_LB_MLB_SOUTH	50_UAT_LB_MLB_SOUTH
73 57 53	50_UAT_MB_HB_SOUTH	50_UAT_MB_HB_SOUTH
75 57 53	50_UAT_LB_MLB_NORTH	50_UAT_LB_MLB_NORTH
75 57 53	50_UAT1_WEST	50_UAT1_WEST
68 58 53	BB_TO_UAT_SCLK BB_TO_UAT_DATA 50_UAT1_TUNER BUFFER_GPO1	UAT_RFFE_CLK UAT_RFFE_DATA 50_UAT1_TUNER BUFFER_GPO1
	Per JimYang 3/17, D11 only, NC BUFFER_GPO2	NCX BUFFER_GPO2
68 58 53 41	BB_TO_LAT_ANT_SCLK BB_TO_LAT_ANT_DATA	LAT_RFFE_CLK LAT_RFFE_DATA
68 41	BB_TO_LAT_GPO1	RFFE_GPO1
68 41	BB_TO_LAT_GPO2	RFFE_GPO2
68 41	BB_TO_LAT_GPO3	RFFE_GPO3
		PMU_TO_GNSS_EN UART_AP_TO_GNSS_TXD UART_GNSS_TO_AP_RXD UART_AP_TO_GNSS_RTS_L UART_GNSS_TO_AP_CTS_L GNSS_TO_PMU_HOST_WAKE AP_TO_GNSS_TIME_MARK

RADIO_MLB

I33

FF SPECIFIC

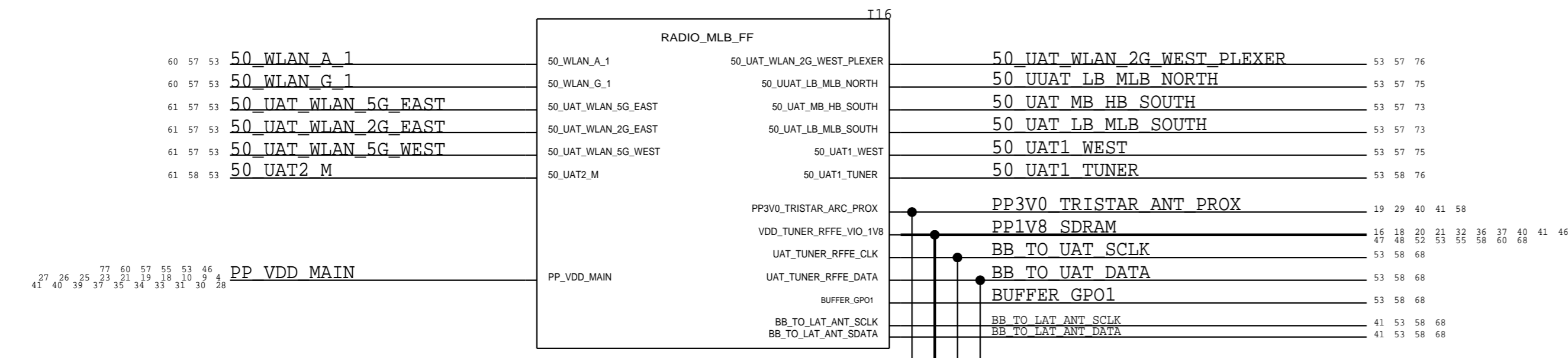

NFC

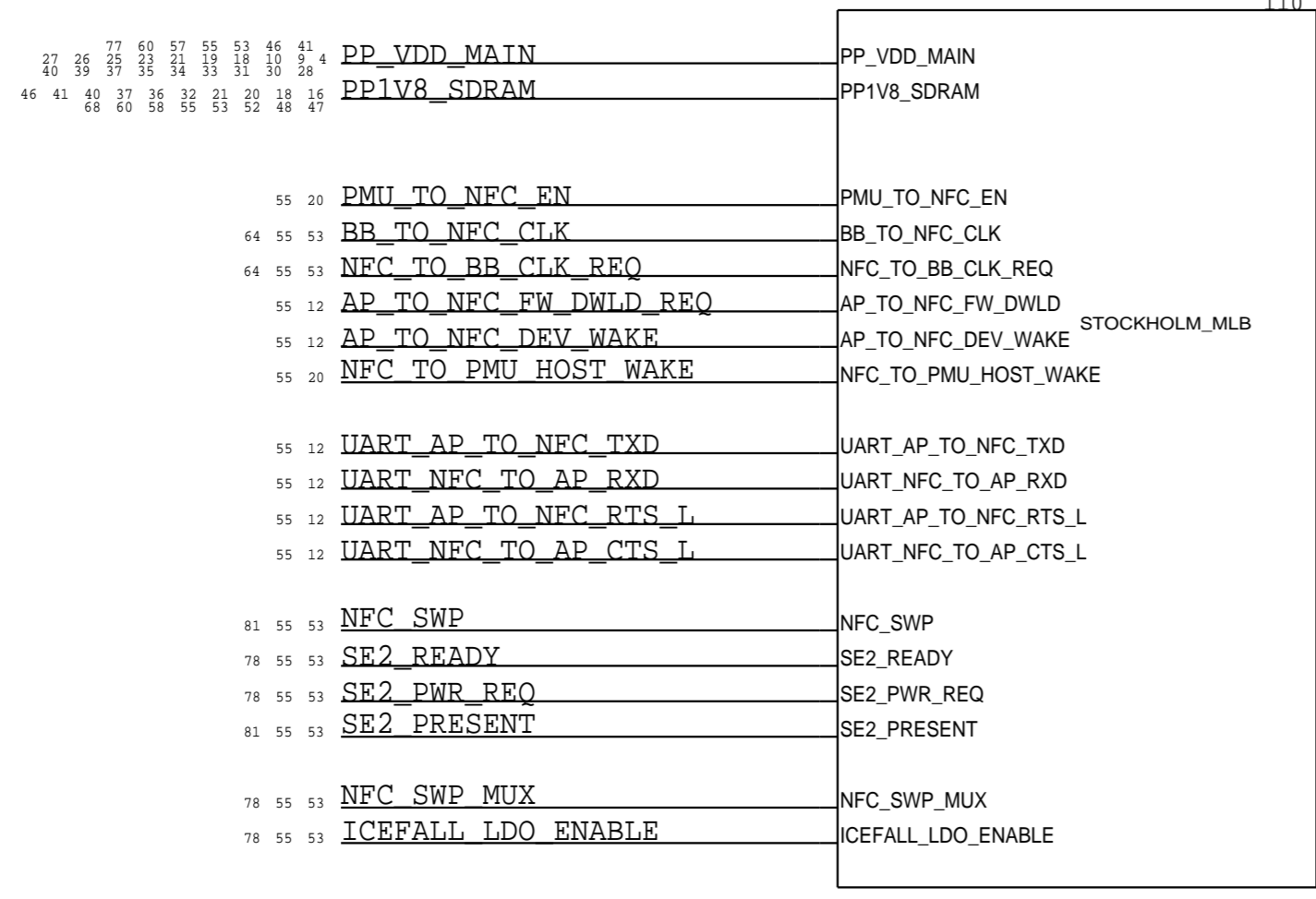

SYNC_MASTER=david-copy SYNC_DATE=03/01/2016

PAGE TITLE

CELL, WIFI, NFC

Apple Inc.

DRAWING NUMBER: 051-00482 SIZE: D

REVISION: 8.0.0

BRANCH:

PAGE: 53 OF 53

SHEET: 53 OF 81

NOTICE OF PROPRIETARY PROPERTY:
THE INFORMATION CONTAINED HEREIN IS THE PROPRIETARY PROPERTY OF APPLE INC. THE POSSESSOR AGREES TO THE FOLLOWING:
I TO MAINTAIN THIS DOCUMENT IN CONFIDENCE
II NOT TO REPRODUCE OR COPY IT
III NOT TO REVEAL OR PUBLISH IT IN WHOLE OR PART
IV ALL RIGHTS RESERVED

1. ALL RESISTANCE VALUES ARE IN OHMS, 0.1 WATT +/- 5%.
 2. ALL CAPACITANCE VALUES ARE IN MICROFARADS.
 3. ALL CRYSTALS & OSCILLATOR VALUES ARE IN HERTZ.

REV	ECN	DESCRIPTION OF REVISION	CK APPD	DATE
8	0006532879	ENGINEERING RELEASED		2016-07-06

STOCKHOLM_MLB

JUNE 22, 2016

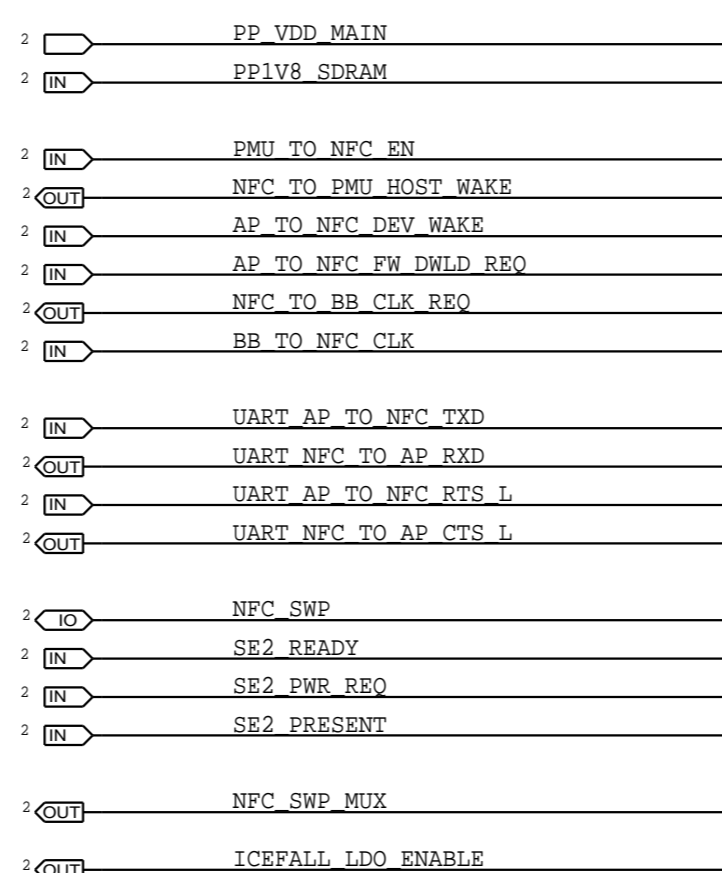

ALTERNATES

PART NUMBER	ALTERNATE FOR PART NUMBER	REFERENCE DESIGNATOR(S)	DESCRIPTION	BOM OPTION
132S0436	132S0400	C7504_RF	0.22UF 20% 6.3V 01005	

PART#	QTY	DESCRIPTION	REFERENCE DESIGNATOR(S)	CRITICAL	BOM OPTION
353801007	1	ONSEMI,IC LOAD SWITCH, WLCSP4	NFCSM_RF	CRITICAL	

BOM OPTIONS

PART#	QTY	DESCRIPTION	REFERENCE DESIGNATOR(S)	BOM OPTION
131S0883	1	220PF, 0201 2% 50V	C7514_RF	D101
131S00055	1	22PF, 0201 2% 50V	C7512_RF	D101
131S00117	1	120PF, 0201 2% 50V	C7518_RF	D101
131S00026	1	820PF, 0201 2% 50V	C7516_RF	D101
131S0883	1	220PF, 0201 2% 50V	C7514_RF	D10_JP
131S00055	1	22PF, 0201 2% 50V	C7512_RF	D10_JP
131S00019	1	150PF, 0201 2% 50V	C7518_RF	D10_JP
131S0825	1	560PF, 0201 2% 50V	C7516_RF	D10_JP
131S0883	1	220PF, 0201 2% 50V	C7514_RF	D10_ROW
131S00055	1	22PF, 0201 2% 50V	C7512_RF	D10_ROW
131S00117	1	120PF, 0201 2% 50V	C7518_RF	D10_ROW
131S00026	1	820PF, 0201 2% 50V	C7516_RF	D10_ROW

PART#	QTY	DESCRIPTION	REFERENCE DESIGNATOR(S)	BOM OPTION
131S00081	1	270PF, 0201 2% 25V	C7514_RF	D111
131S00118	1	180PF, 0201 2% 50V	C7518_RF	D111
131S00033	1	680PF, 0201 2% 50V	C7516_RF	D111
131S00081	1	270PF, 0201 2% 25V	C7514_RF	D11_JP
131S0731	1	100PF, 0201 2% 50V	C7518_RF	D11_JP
131S00033	1	680PF, 0201 2% 50V	C7516_RF	D11_JP
131S00081	1	270PF, 0201 2% 25V	C7514_RF	D11_ROW
131S00118	1	180PF, 0201 2% 50V	C7518_RF	D11_ROW
131S00033	1	680PF, 0201 2% 50V	C7516_RF	D11_ROW

page1

DRAWING TITLE SCH, MLB, D11		DRAWING NUMBER 051-00482	SIZE D
		REVISION 8.0.0	BRANCH
		PAGE 1 OF 75	SHEET 54 OF 81
NOTICE OF PROPRIETARY PROPERTY: THE INFORMATION CONTAINED HEREIN IS THE PROPRIETARY PROPERTY OF APPLE INC. THE POSSESSOR AGREES TO THE FOLLOWING: I TO MAINTAIN THIS DOCUMENT IN CONFIDENCE II NOT TO REPRODUCE OR COPY IT III NOT TO REVEAL OR PUBLISH IT IN WHOLE OR PART IV ALL RIGHTS RESERVED			

STOCKHOLM

NFC CONTROLLER

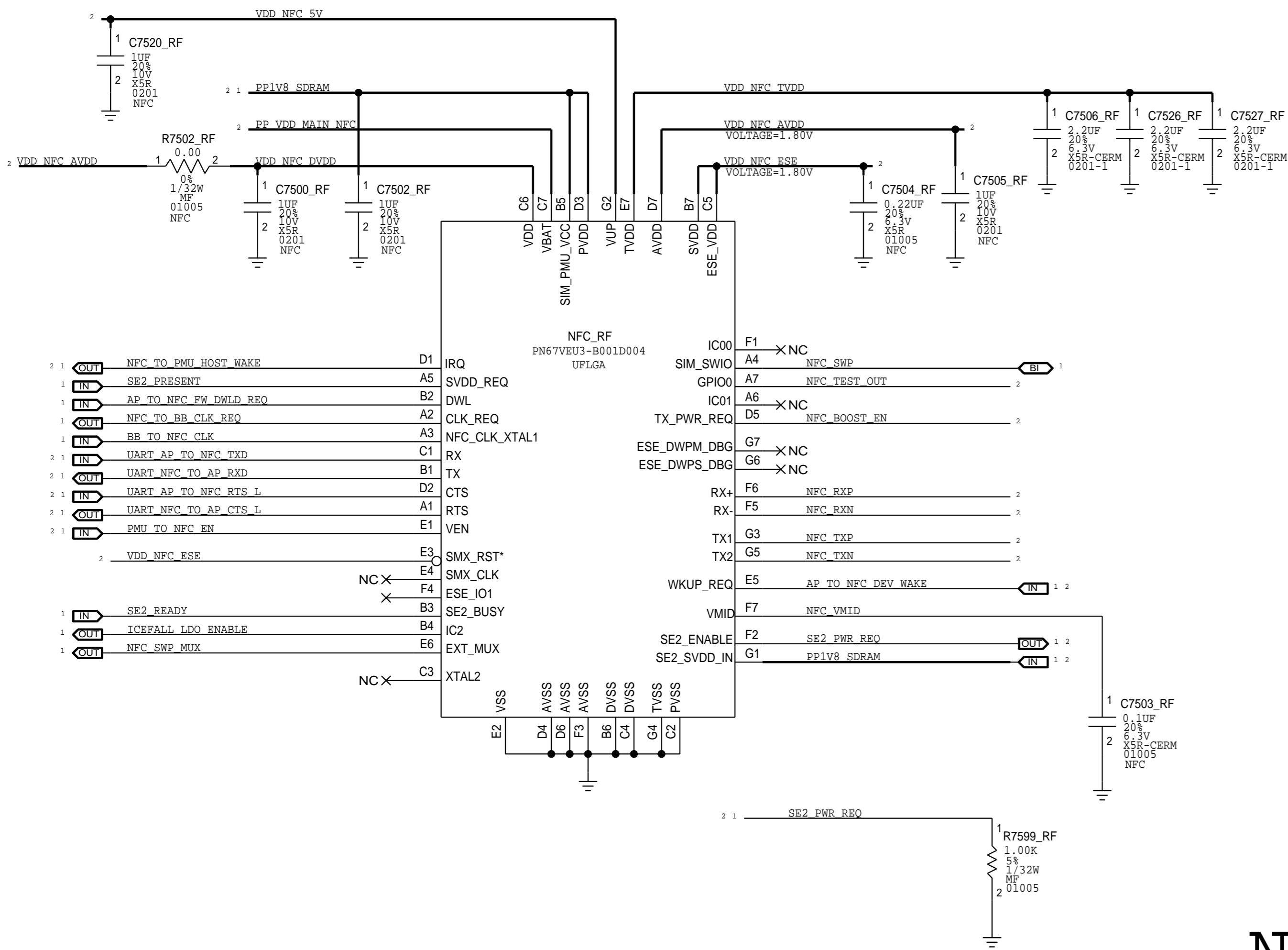

5V BOOSTER

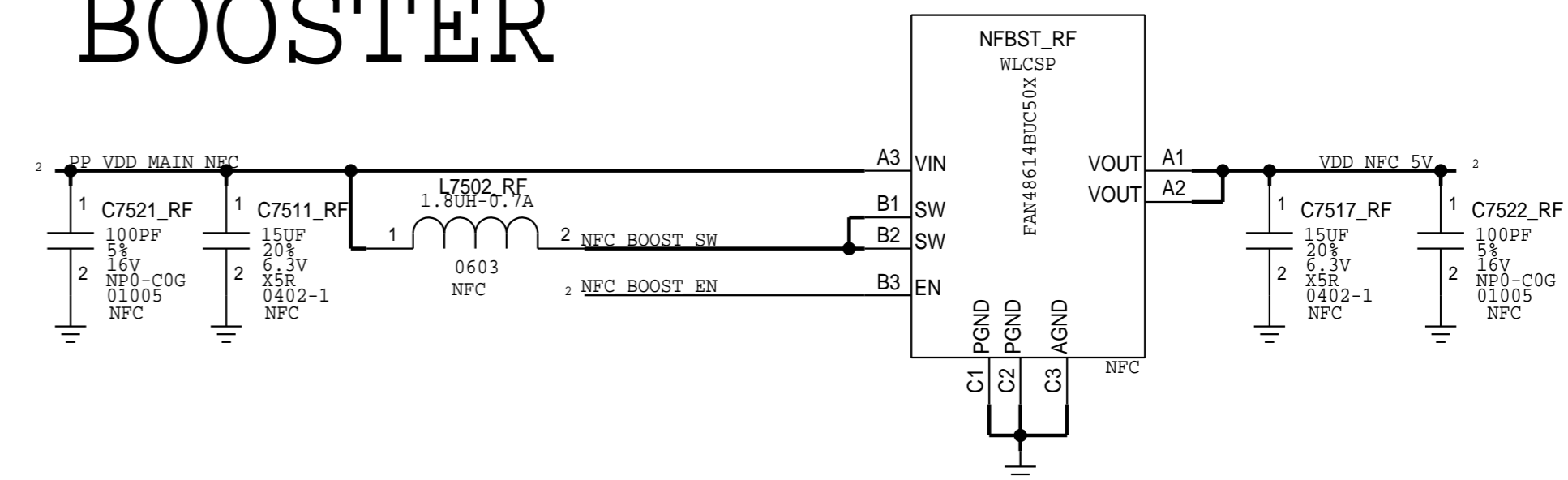

NFC FRONT END

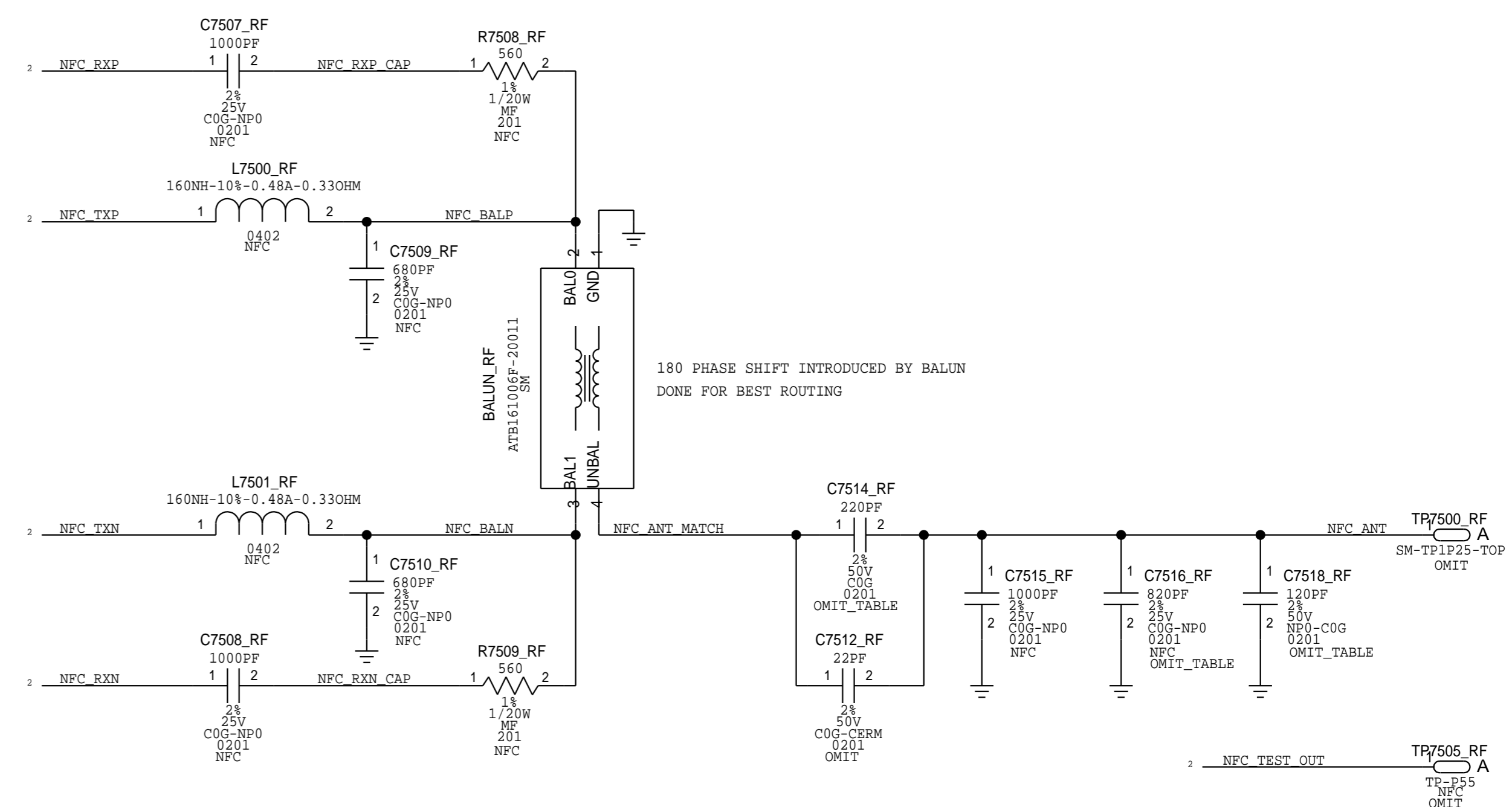

NFC LOAD SWITCH

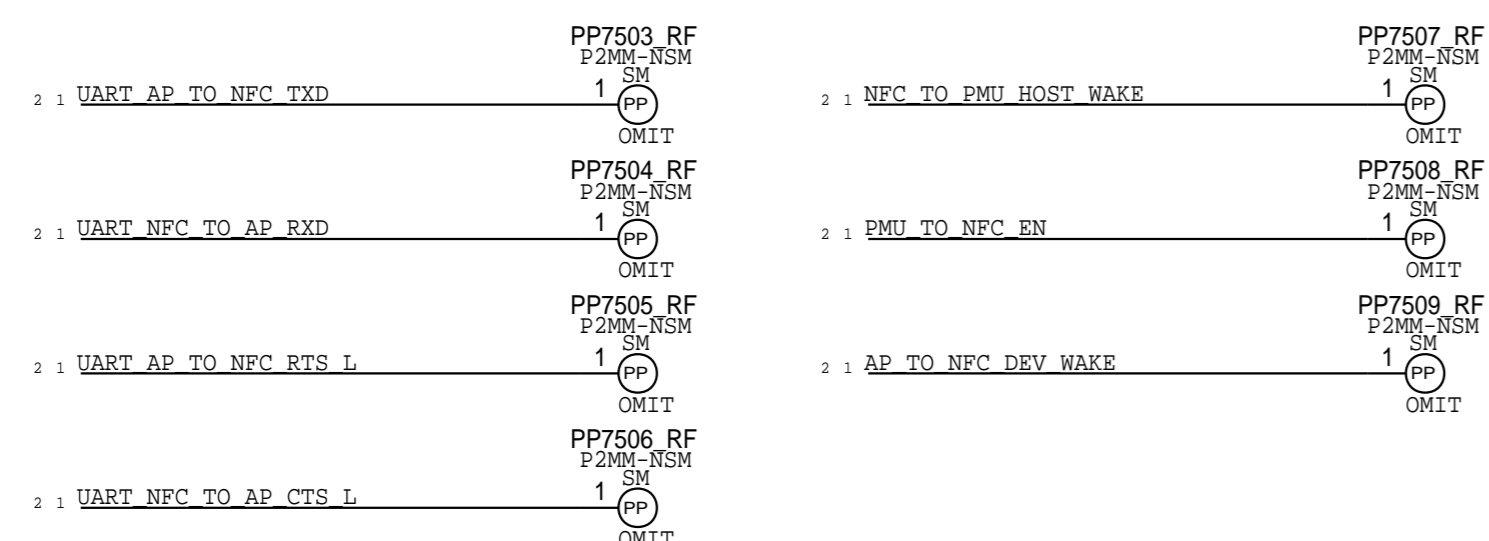
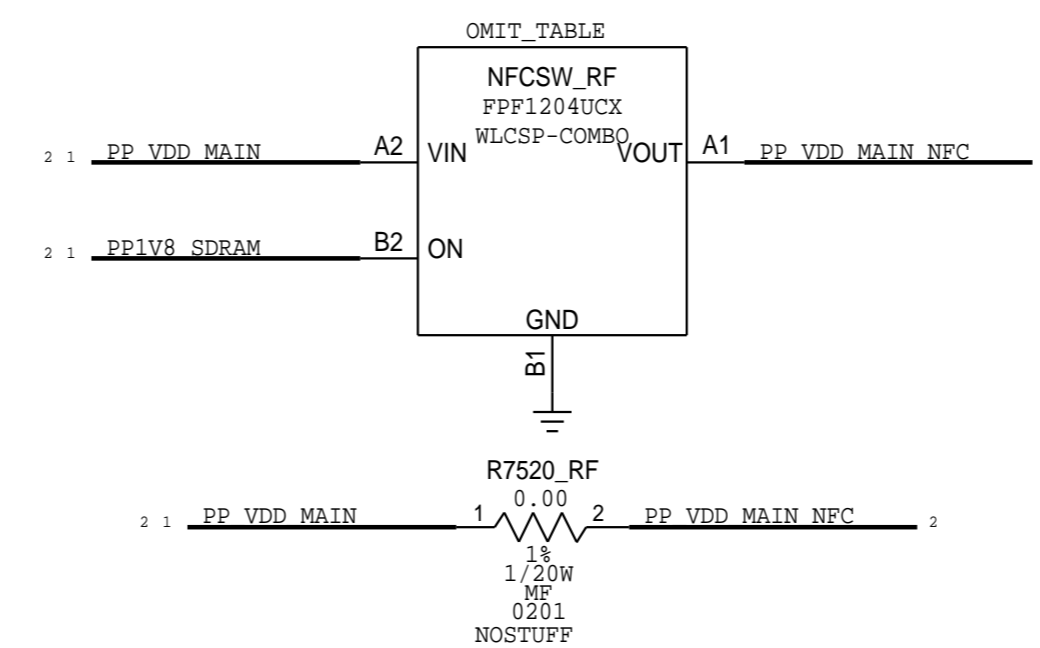

PAGE TITLE		
NFC		
	DRAWING NUMBER	051-00482
	REVISION	8.0.0
NOTICE OF PROPRIETARY PROPERTY:		
THE INFORMATION CONTAINED HEREIN IS THE PROPRIETARY PROPERTY OF APPLE INC. THE POSSESSOR AGREES TO THE FOLLOWING: I TO MAINTAIN THIS DOCUMENT IN CONFIDENCE II NOT TO REPRODUCE OR COPY IT III NOT TO REVEAL OR PUBLISH IT IN WHOLE OR PART IV ALL RIGHTS RESERVED		
BRANCH		
PAGE	75 OF 75	
SHEET	55 OF 81	

8

7

6

5

4

3

2

1

1. ALL RESISTANCE VALUES ARE IN OHMS, 0.1 WATT +/- 5%.
 2. ALL CAPACITANCE VALUES ARE IN MICROFARADS.
 3. ALL CRYSTALS & OSCILLATOR VALUES ARE IN HERTZ.

REV	ECN	DESCRIPTION OF REVISION	CK APPD	DATE
8	0006532879	ENGINEERING RELEASED		2016-07-06

D11 RADIO_MLB_FF

FEB 05, 2016

PDF PAGE	CONTENTS
2	METROCIRC

LMBRF:

PART#	QTY	DESCRIPTION	REFERENCE DESIGNATOR(S)	CRITICAL	BOM OPTION
152S2001	1	2.400K, 6000W, 0201	L8008_RF	CRITICAL	LMBRF
152S0983	1	6.800K, 2W, 1.5A, 0.05500W, 0402	L8009_RF	CRITICAL	LMBRF

NOLMBRF:

PART#	QTY	DESCRIPTION	REFERENCE DESIGNATOR(S)	CRITICAL	BOM OPTION
152S2024	1	1.400K, 1.1A, 0201	L8008_RF	CRITICAL	NOLMBRF
152S00610	1	3.600K, 2W, 1.7A, 0.04500W, 0402	L8009_RF	CRITICAL	NOLMBRF

?

DRAWING TITLE		SCH, MLB, D11	
 Apple Inc.	DRAWING NUMBER	051-00482	SIZE
	REVISION	8.0.0	D
NOTICE OF PROPRIETARY PROPERTY: THE INFORMATION CONTAINED HEREIN IS THE PROPRIETARY PROPERTY OF APPLE INC. THE POSSESSOR AGREES TO THE FOLLOWING: I TO MAINTAIN THIS DOCUMENT IN CONFIDENCE II NOT TO REPRODUCE OR COPY IT III NOT TO REVEAL OR PUBLISH IT IN WHOLE OR PART IV ALL RIGHTS RESERVED		BRANCH	
		PAGE	1 OF 3
		SHEET	56 OF 81

METROCIRC

D11 NORTH-SOUTH METROCIRC
339S00147

D11 EAST-WEST METROCIRC
339S00146



WIFI LOWER ANTENNA FEED

COAX

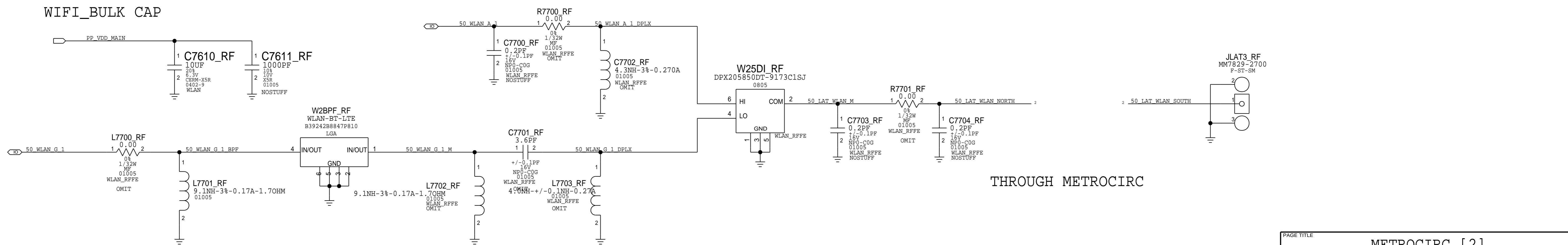

PAGE TITLE		METROCIRC [2]	
Apple Inc.		DRAWING NUMBER	051-00482
		REVISION	8.0.0
NOTICE OF PROPRIETARY PROPERTY: THE INFORMATION CONTAINED HEREIN IS THE PROPRIETARY PROPERTY OF APPLE INC. THE POSSESSOR AGREES TO THE FOLLOWING: I TO MAINTAIN THIS DOCUMENT IN CONFIDENCE II NOT TO REPRODUCE OR COPY IT III NOT TO REVEAL OR PUBLISH IT IN WHOLE OR PART IV ALL RIGHTS RESERVED		BRANCH	
		PAGE	2 OF 3
		SHEET	57 OF 81

UAT TUNER FLEX

PLEASE CONTACT ANTENNA (MATT MOW)
FOR ANY COMPONENT CHANGE.

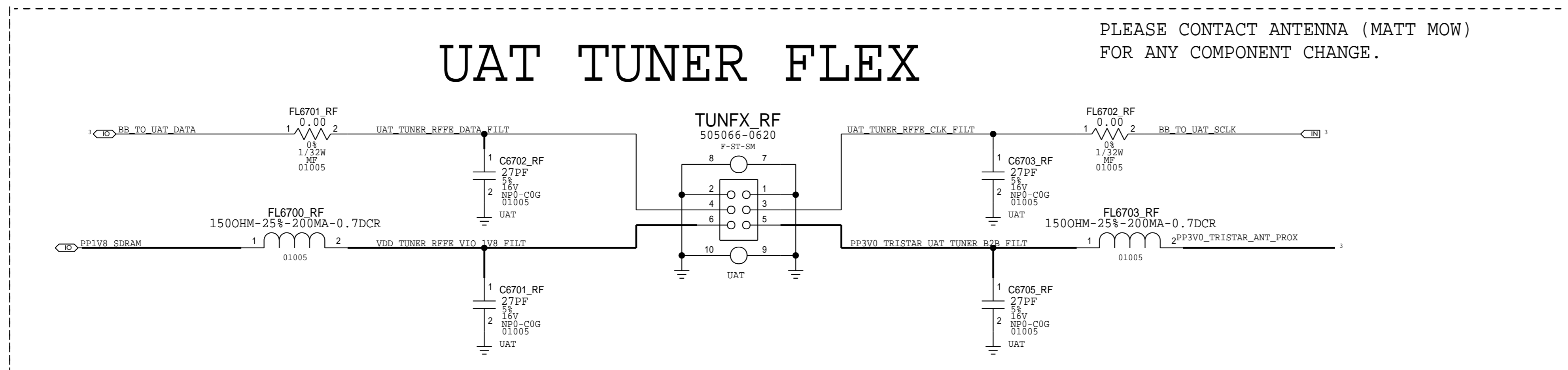

ALT UAT1 GND

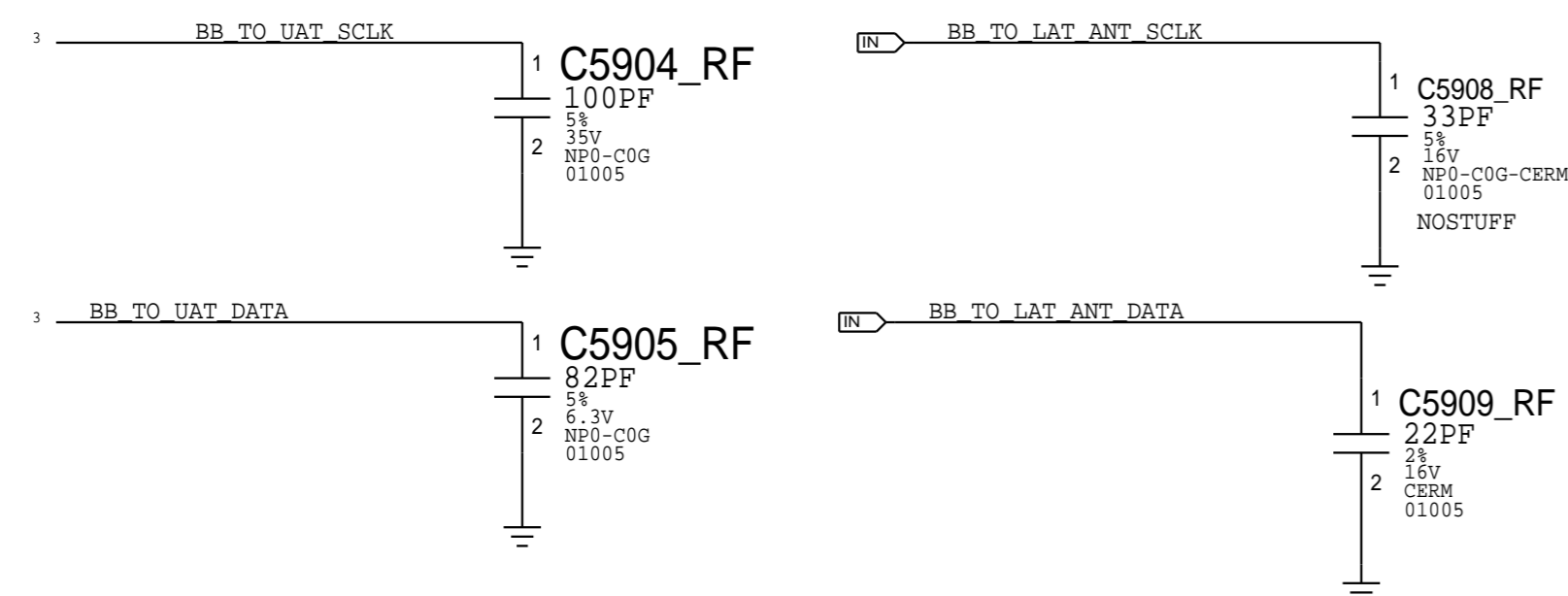

LB/MLB/GNSS/MB/HB STANDOFF

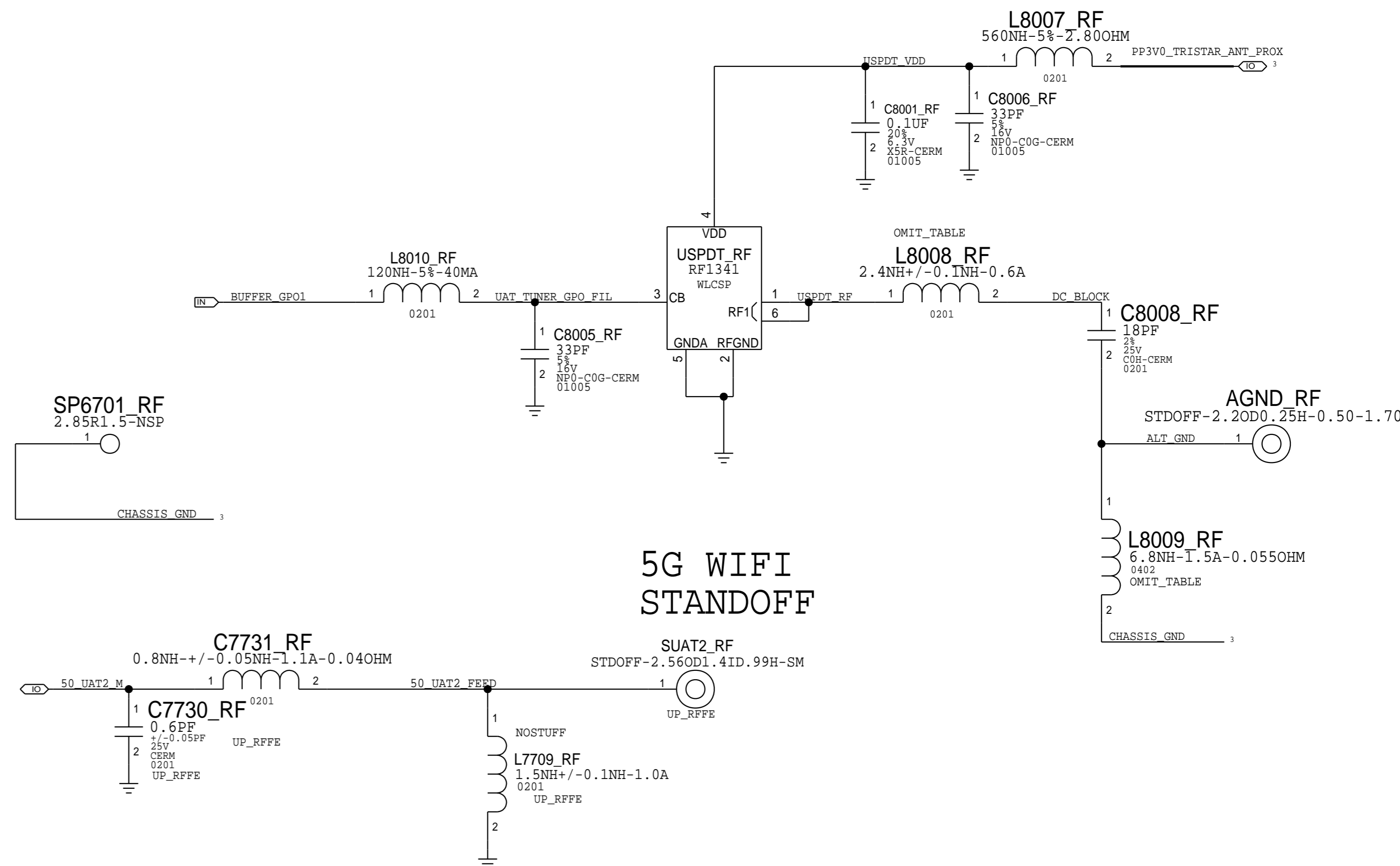
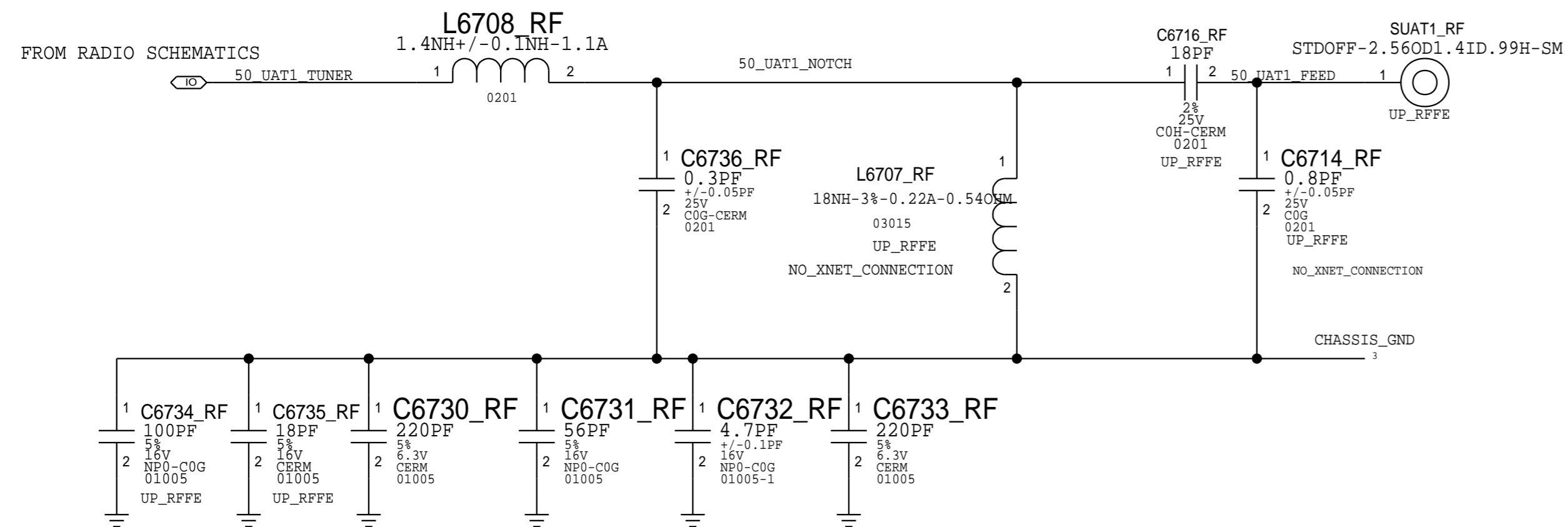

5G WIFI STANDOFF

PAGE TITLE UAT MATCH AND TUNER [3]		
Apple Inc.	DRAWING NUMBER	051-00482
	REVISION	8.0.0
NOTICE OF PROPRIETARY PROPERTY: THE INFORMATION CONTAINED HEREIN IS THE PROPRIETARY PROPERTY OF APPLE INC. THE POSSESSOR AGREES TO THE FOLLOWING: I TO MAINTAIN THIS DOCUMENT IN CONFIDENCE II NOT TO REPRODUCE OR COPY IT III NOT TO REVEAL OR PUBLISH IT IN WHOLE OR PART IV ALL RIGHTS RESERVED	BRANCH	
	PAGE	3 OF 3
	SHEET	58 OF 81

- 1. ALL RESISTANCE VALUES ARE IN OHMS, 0.1 WATT +/- 5%.
- 2. ALL CAPACITANCE VALUES ARE IN MICROFARADS.
- 3. ALL CRYSTALS & OSCILLATOR VALUES ARE IN HERTZ.

REV	ECN	DESCRIPTION OF REVISION	CK APPD	DATE
8	0006532879	ENGINEERING RELEASED		2016-07-06

D1X WIFI_MLB (PERENNIAL)

FEBRUARY 1, 2016

PDF PAGE	CSA PAGE	CONTENTS
2	76	PERENNIAL
3	77	WIFI FRONT-END

BOM OPTIONS:

POWER

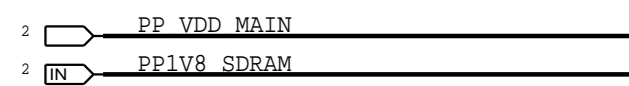

CLOCKS



CONTROL

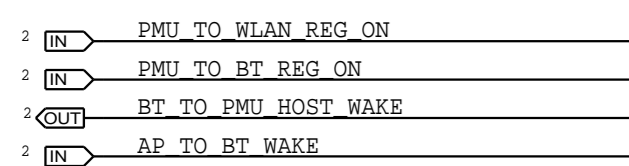

WLAN PCIE

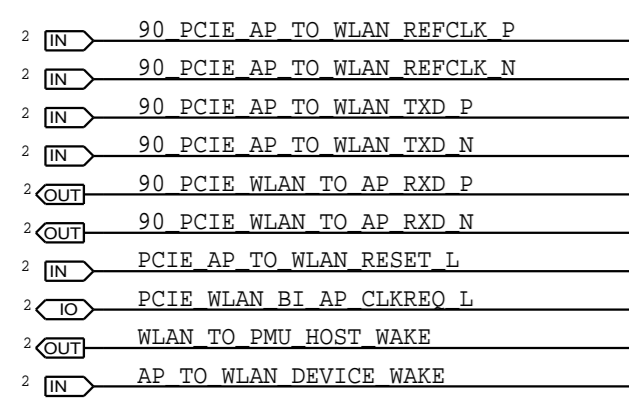

WLAN UART

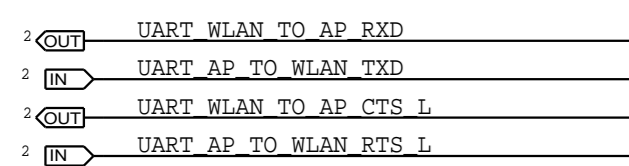

BLUETOOTH UART

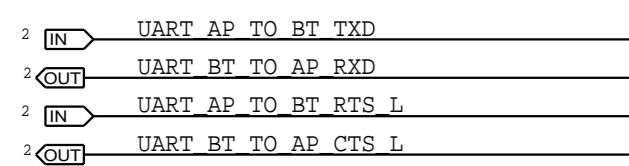

AOP

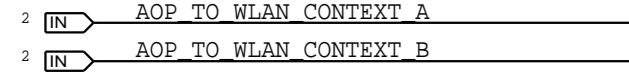

AUDIO

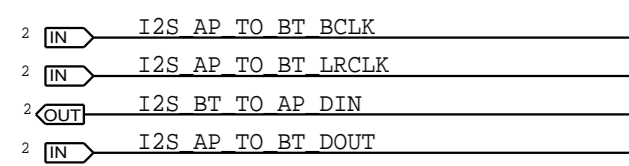

COEX

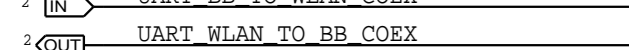

ANTENNA

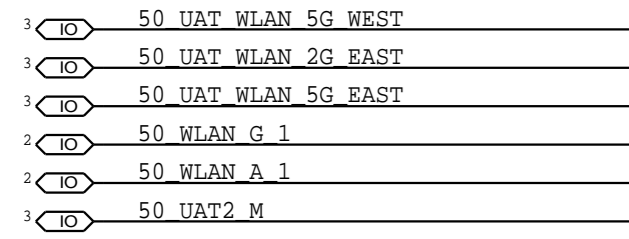

D10_JP:

PART#	QTY	DESCRIPTION	REFERENCE DESIGNATOR(S)	CRITICAL	BOM OPTION
131S0648	1	CAP,CER,0.3PF,+/-0.05,01005	C7705_RF	CRITICAL	D10_JP
152S00029	1	IND,1.1NH,UH-Q,01005	R7703_RF	CRITICAL	D10_JP
131S0893	1	CAP,CER,0.2PF,+/-0.05,01005	C7706_RF	CRITICAL	D10_JP
117S0161	1	RES,MF,0 OHM,1/32W,01005	R7711_RF	CRITICAL	D10_JP
117S0161	1	RES,MF,0 OHM,1/32W,01005	R7702_RF	CRITICAL	D10_JP
152S1980	1	IND,1.0NH,UH-Q,01005	R7704_RF	CRITICAL	D10_JP
131S0404	1	CAP,3.9PF,+/-1.0PF,01005	R6711_RF	CRITICAL	D10_JP
152S2061	1	IND,7.5NH,UH-Q,01005	C6729_RF	CRITICAL	D10_JP
117S0161	1	RES,MF,0 OHM,1/32W,01005	R7700_RF	CRITICAL	D10_JP
152S2043	1	IND,6.2NH,UH-Q,01005	C7702_RF	CRITICAL	D10_JP
152S1998	1	IND,0.8NH,UH-Q,01005	L7700_RF	CRITICAL	D10_JP
152S2043	1	IND,6.2NH,UH-Q,01005	L7701_RF	CRITICAL	D10_JP
152S1853	1	IND,9.1NH,UH-Q,01005	L7702_RF	CRITICAL	D10_JP
131S0401	1	CAP,3.6PF,+/-0.1PF,01005	C7701_RF	CRITICAL	D10_JP
152S00038	1	IND,4.0NH,+/-0.1NH,UH-Q,01005	L7703_RF	CRITICAL	D10_JP
117S0161	1	RES,MF,0 OHM,1/32W,01005	R7701_RF	CRITICAL	D10_JP

NOSTUFF:C7729_RF,C7711_RF,C7709_RF,C7710_RF, C7707_RF, C7708_RF
C7700_RF, C7703_RF,C7704_RF

D10_ROW:

PART#	QTY	DESCRIPTION	REFERENCE DESIGNATOR(S)	CRITICAL	BOM OPTION
131S0648	1	CAP,CER,0.3PF,+/-0.05,01005	C7705_RF	CRITICAL	D10_ROW
152S00029	1	IND,1.1NH,UH-Q,01005	R7703_RF	CRITICAL	D10_ROW
131S0893	1	CAP,CER,0.2PF,+/-0.05,01005	C7706_RF	CRITICAL	D10_ROW
117S0161	TRUE	RES,MF,0 OHM,1/32W,01005	R7711_RF	CRITICAL	D10_ROW
117S0161	TRUE	RES,MF,0 OHM,1/32W,01005	R7702_RF	CRITICAL	D10_ROW
152S1980	TRUE	IND,2.4NH,UH-Q,01005	R7704_RF	CRITICAL	D10_ROW
117S0161	TRUE	RES,MF,0 OHM,1/32W,01005	R6711_RF	CRITICAL	D10_ROW
152S1853	TRUE	IND,9.1NH,UH-Q,01005	C6729_RF	CRITICAL	D10_ROW
117S0161	TRUE	RES,MF,0 OHM,1/32W,01005	R7700_RF	CRITICAL	D10_ROW
152S2043	1	IND,6.2NH,UH-Q,01005	C7702_RF	CRITICAL	D10_ROW
152S1998	1	IND,0.8NH,UH-Q,01005	L7700_RF	CRITICAL	D10_ROW
152S2043	1	IND,6.2NH,UH-Q,01005	L7701_RF	CRITICAL	D10_ROW
152S1853	1	IND,9.1NH,UH-Q,01005	L7702_RF	CRITICAL	D10_ROW
131S0401	1	CAP,3.6PF,+/-0.1PF,01005	C7701_RF	CRITICAL	D10_ROW
152S00038	TRUE	IND,4.0NH,+/-0.1NH,UH-Q,01005	L7703_RF	CRITICAL	D10_ROW
117S0161	1	RES,MF,0 OHM,1/32W,01005	R7701_RF	CRITICAL	D10_ROW

NOSTUFF:C7729_RF,C7711_RF,C7709_RF,C7710_RF, C7707_RF, C7708_RF
C7700_RF, C7703_RF,C7704_RF

D101_WIFI:

PART#	QTY	DESCRIPTION	REFERENCE DESIGNATOR(S)	CRITICAL	BOM OPTION
131S0648	1	CAP,CER,0.3PF,+/-0.05,01005	C7705_RF	CRITICAL	D101
152S00029	1	IND,1.1NH,UH-Q,01005	R7703_RF	CRITICAL	D101
131S0893	1	CAP,CER,0.2PF,+/-0.05,01005	C7706_RF	CRITICAL	D101
117S0161	1	RES,MF,0 OHM,1/32W,01005	R7711_RF	CRITICAL	D101
117S0161	1	RES,MF,0 OHM,1/32W,01005	R7702_RF	CRITICAL	D101
152S1988	TRUE	IND,2.4NH,UH-Q,01005	R7704_RF	CRITICAL	D101
131S0648	TRUE	CAP,CER,0.3PF,+/-0.05PF,01005	C7708_RF	CRITICAL	D101
118S0724	TRUE	RES,MF,0 OHM,1/20W,0201	R6711_RF	CRITICAL	D101
152S2054	TRUE	IND,9.1NH,UH-Q,0201	C6729_RF	CRITICAL	D101
117S0161	1	RES,MF,0 OHM,1/32W,01005	R7700_RF	CRITICAL	D101
152S2043	TRUE	IND,6.2NH,UH-Q,01005	C7702_RF	CRITICAL	D101
152S1998	1	IND,0.8NH,UH-Q,01005	L7700_RF	CRITICAL	D101
152S2043	1	IND,6.2NH,UH-Q,01005	L7701_RF	CRITICAL	D101
152S1853	1	IND,9.1NH,UH-Q,01005	L7702_RF	CRITICAL	D101
131S0401	1	CAP,3.6PF,+/-0.1PF,01005	C7701_RF	CRITICAL	D101
152S00038	1	IND,4.0NH,+/-0.1NH,UH-Q,01005	L7703_RF	CRITICAL	D101
117S0161	1	RES,MF,0 OHM,1/32W,01005	R7701_RF	CRITICAL	D101

NOSTUFF: C7729_RF,C7711_RF,C7709_RF,C7710_RF, C7707_RF, C7708_RF
C7700_RF, C7703_RF,C7704_RF

D11_JP:

PART#	QTY	DESCRIPTION	REFERENCE DESIGNATOR(S)	CRITICAL	BOM OPTION
152S00273	TRUE	IND,0.6NH,UH-Q,01005	R7703_RF	CRITICAL	D11_JP
152S1976	TRUE	IND,0.7NH,UH-Q,01005	R7711_RF	CRITICAL	D11_JP
131S0400	TRUE	CAP,CER,3.5PF,+/-0.1,01005	R7702_RF	CRITICAL	D11_JP
152S1986	TRUE	IND,FILM,2.2NH,UH-Q,01005	R7704_RF	CRITICAL	D11_JP
131S0648	1	CAP,CER,0.3PF,+/-0.05PF,01005	C7708_RF	CRITICAL	D11_JP
131S0593	TRUE	CAP,3.9PF,+/-1.0PF,0201,HI-Q	R6711_RF	CRITICAL	D11_JP
152S2055	TRUE	IND,7.5NH,UH-Q,0201	C6729_RF	CRITICAL	D11_JP
131S0893	TRUE	CAP,CER,0.2PF,+/-0.05PF,01005	C7705_RF	CRITICAL	D11_JP
131S0893	TRUE	CAP,CER,0.2PF,+/-0.05PF,01005	C7729_RF	CRITICAL	D11_JP
131S0648	TRUE	CAP,CER,0.3PF,+/-0.05PF,01005	C7700_RF	CRITICAL	D11_JP
152S1980	TRUE	IND,1.0NH,+/-0.1NH,UH-Q,01005	R7700_RF	CRITICAL	D11_JP
131S0648	TRUE	CAP,CER,0.3PF,+/-0.05PF,01005	C7702_RF	CRITICAL	D11_JP
131S0405	1	CAP,CER,4.0PF,+/-0.1PF,01005	R7701_RF	CRITICAL	D11_JP
152S00273	1	IND,0.6NH,+/-1NH,UH-Q,01005	L7700_RF	CRITICAL	D11_JP
152S1853	1	IND,9.1NH,UH-Q,01005	L7701_RF	CRITICAL	D11_JP
152S1853	1	IND,9.1NH,UH-Q,01005	L7702_RF	CRITICAL	D11_JP
117S0161	1	RES,MF,0 OHM,1/32W,01005	C7701_RF	CRITICAL	D11_JP

NOSTUFF:C7706_RF, C7711_RF,C7709_RF,C7710_RF, C7707_RF
C7703_RF,C7704_RF,L7703_RF

D11_ROW:

PART#	QTY	DESCRIPTION	REFERENCE DESIGNATOR(S)	CRITICAL	BOM OPTION
152S00273	1	IND,0.6NH,UH-Q,01005	R7703_RF	CRITICAL	D11_ROW
152S1976	1	IND,0.7NH,UH-Q,01005	R7711_RF	CRITICAL	D11_ROW
131S0400	1	CAP,CER,3.5PF,+/-0.1,01005	R7702_RF	CRITICAL	D11_ROW
152S1986	TRUE	IND,FILM,2.2NH,UH-Q,01005	R7704_RF	CRITICAL	D11_ROW
118S0724	TRUE	RES,MF,0 OHM,1/20W,0201	R6711_RF	CRITICAL	D11_ROW
152S2054	TRUE	IND,9.1NH,UH-Q,0201	C6729_RF	CRITICAL	D11_ROW
131S0893	1	CAP,CER,0.2PF,+/-0.05PF,01005	C7705_RF	CRITICAL	D11_ROW
131S0893	1	CAP,CER,0.2PF,+/-0.05PF,01005	C7729_RF	CRITICAL	D11_ROW
131S0648	TRUE	CAP,CER,0.3PF,+/-0.05PF,01005	C7700_RF	CRITICAL	D11_ROW
152S1980	TRUE	IND,1.0NH,+/-0.1NH,UH-Q,01005	R7700_RF	CRITICAL	D11_ROW
131S0648	TRUE	CAP,CER,0.3PF,+/-0.05PF,01005	C7702_RF	CRITICAL	D11_ROW
131S0405	1	CAP,CER,4.0PF,+/-0.1PF,01005	R7701_RF	CRITICAL	D11_ROW
152S00273	1	IND,0.6NH,+/-1NH,UH-Q,01005	L7700_RF	CRITICAL	D11_ROW
152S1853	1	IND,9.1NH,UH-Q,01005	L7701_RF	CRITICAL	D11_ROW
152S1853	1	IND,9.1NH,UH-Q,01005	L7702_RF	CRITICAL	D11_ROW
117S0161	1	RES,MF,0 OHM,1/32W,01005	C7701_RF	CRITICAL	D11_ROW

NOSTUFF:C7706_RF, C7711_RF,C7709_RF,C7710_RF, C7707_RF, C7708_RF
C7703_RF,C7704_RF,L7703_RF

D111_WIFI:

PART#	QTY	DESCRIPTION	REFERENCE DESIGNATOR(S)	CRITICAL	BOM OPTION
152S00273	1	IND,0.6NH,UH-Q,01005	R7703_RF	CRITICAL	D111
152S1976	1	IND,0.7NH,UH-Q,01005	R7711_RF	CRITICAL	D111
131S0400	1	CAP,CER,3.5PF,+/-0.1,01005	R7702_RF	CRITICAL	D111
152S1986	TRUE	IND,FILM,2.2NH,UH-Q,01005	R7704_RF	CRITICAL	D111
118S0724	TRUE	RES,MF,0 OHM,1/20W,0201	R6711_RF	CRITICAL	D111
152S2054	TRUE	IND,9.1NH,UH-Q,0201	C6729_RF	CRITICAL	D111
131S0893	1	CAP,CER,0.2PF,+/-0.05PF,01005	C7705_RF	CRITICAL	D111
131S0893	TRUE	CAP,CER,0.2PF,+/-0.05PF,01005	C7729_RF	CRITICAL	D111
131S0648	TRUE	CAP,CER,0.3PF,+/-0.05PF,01005	C7700_RF	CRITICAL	D111
152S1980	TRUE	IND,1.0NH,+/-0.1NH,UH-Q,01005	R7700_RF	CRITICAL	D111
131S0648	TRUE	CAP,CER,0.3PF,+/-0.05PF,01005	C7702_RF	CRITICAL	D111
131S0405	1	CAP,CER,4.0PF,+/-0.1PF,01005	R7701_RF	CRITICAL	D111
152S00273	1	IND,0.6NH,+/-1NH,UH-Q,01005	L7700_RF	CRITICAL	D111
152S1853	1	IND,9.1NH,UH-Q,01005	L7701_RF	CRITICAL	D111
152S1853	1	IND,9.1NH,UH-Q,01005	L7702_RF	CRITICAL	D111
117S0161	1	RES,MF,0 OHM,1/32W,01005	C7701_RF	CRITICAL	D111

NOSTUFF:C7706_RF, C7711_RF,C7709_RF,C7710_RF, C7707_RF, C7708_RF
C7703_RF,C7704_RF,L7703_RF

WIFI_MLB SCHEMATIC

DRAWING TITLE		SCH,MLB,D11	
	Apple Inc.	DRAWING NUMBER	051-00482
		REVISION	8.0.0
NOTICE OF PROPRIETARY PROPERTY:		BRANCH	
THE INFORMATION CONTAINED HEREIN IS THE PROPRIETARY PROPERTY OF APPLE INC. THE POSSESSOR AGREES TO THE FOLLOWING:		PAGE	1 OF 77
I TO MAINTAIN THIS DOCUMENT IN CONFIDENCE		SHEET	59 OF 81
I NOT TO REPRODUCE OR COPY IT			
I NOT TO REVEAL OR PUBLISH IT IN WHOLE OR PART			
I ALL RIGHTS RESERVED			

WIFI/BT

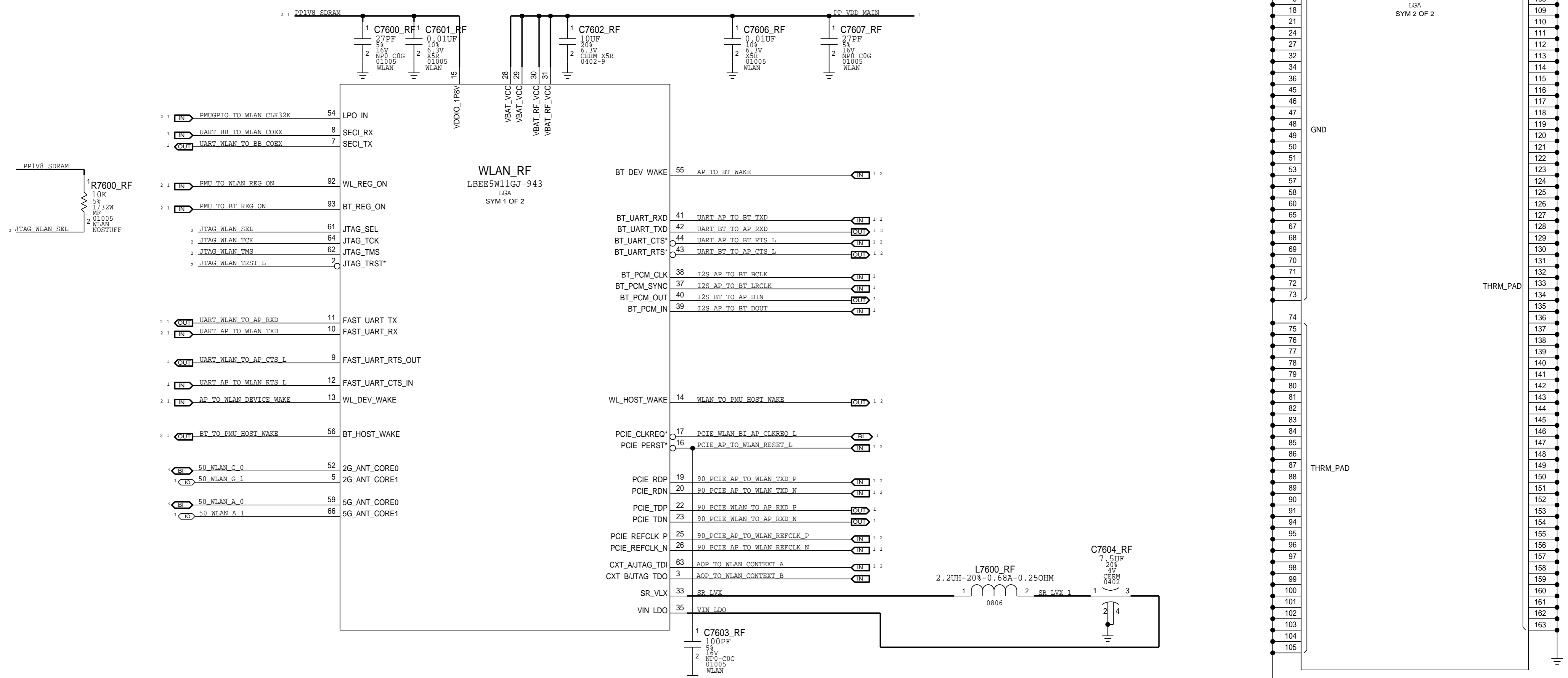

PART NUMBER	ALTERNATE FOR PART NUMBER	BOM OPTION	REF DES	COMMENTS:
339800201	339800199	ALTERNATE	WLAN_RF	ALT WIFI/BT MODULE

1	AOP TO WLAN CONTEXT A TDI	PP7600_RF	2	PMU5PIO TO WLAN CLK32K	PP7610_RF
1	AOP TO WLAN CONTEXT B TDO	PP7601_RF	1	WLAN TO PMU HOST WAKE	PP7611_RF
1	UART WLAN TO AP RXD	PP7603_RF	1	90 PCIE AP TO WLAN REFCLK P	PP7612_RF
1	UART AP TO WLAN TXD	PP7604_RF	1	90 PCIE AP TO WLAN REFCLK N	PP7613_RF
1	JTAG WLAN TCK	PP7605_RF	1	90 PCIE AP TO WLAN TXD P	PP7614_RF
1	JTAG WLAN TMS	PP7606_RF	1	90 PCIE AP TO WLAN TXD N	PP7615_RF
1	JTAG WLAN TRST L	PP7607_RF	1	PCIE AP TO WLAN RESET L	PP7616_RF
1	AP TO WLAN DEVICE WAKE	PP7608_RF	1	JTAG WLAN SEL	PP7617_RF
1	BT TO PMU HOST WAKE	PP7609_RF	1	PMU TO WLAN REG_ON	PP7618_RF
1			1	PMU TO BT REG_ON	PP7619_RF

VIETMOBILE.VN

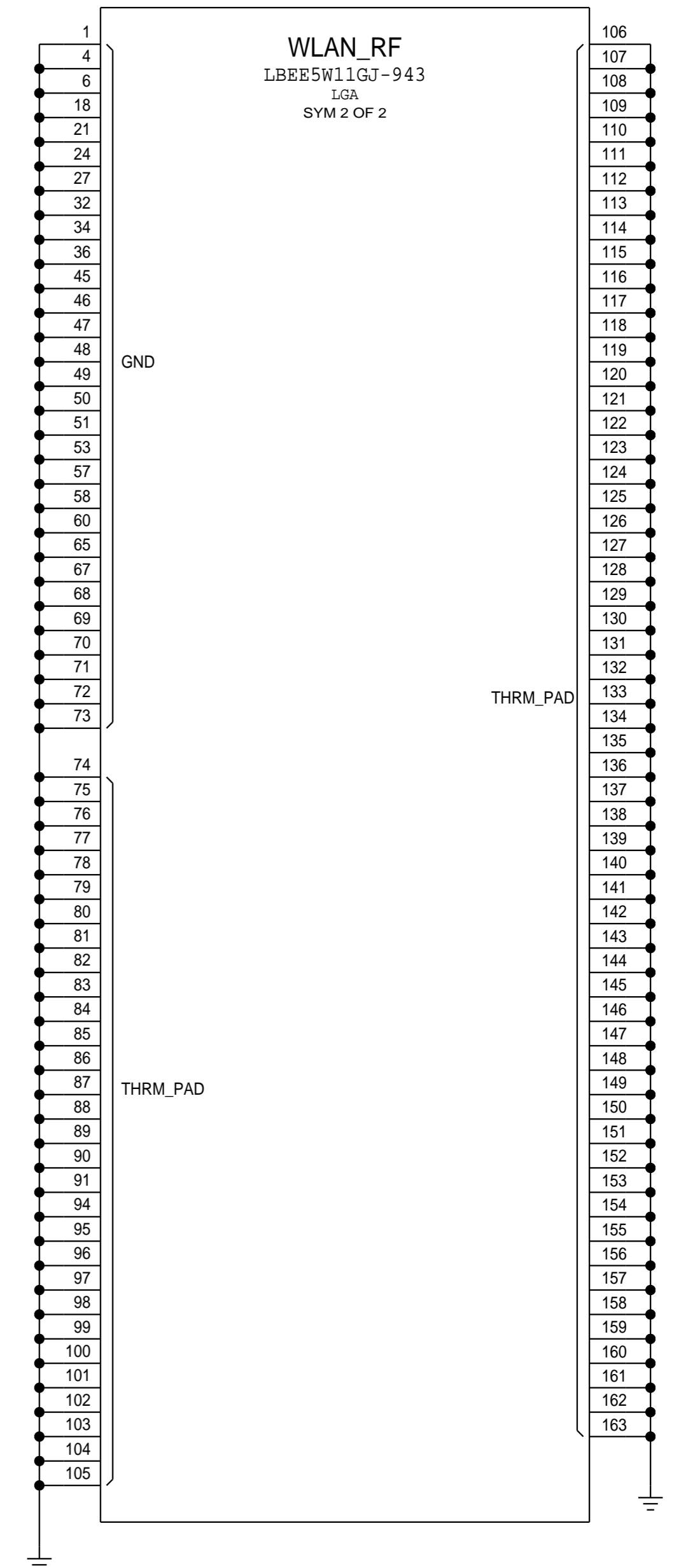

SYNC_MASTER=WIFI SYNC_DATE=01/30/2014

PAGE TITLE PERENNIAL

Apple Inc.

NOTICE OF PROPRIETARY PROPERTY:
 THE INFORMATION CONTAINED HEREIN IS THE PROPRIETARY PROPERTY OF APPLE INC. THE POSSESSOR AGREES TO THE FOLLOWING:
 I TO MAINTAIN THIS DOCUMENT IN CONFIDENCE
 II NOT TO REPRODUCE OR COPY IT
 III NOT TO REVEAL OR PUBLISH IT IN WHOLE OR PART
 IV ALL RIGHTS RESERVED

DRAWING NUMBER	051-00482	SIZE	D
REVISION	8.0.0	BRANCH	
PAGE	76 OF 77	SHEET	60 OF 81

WIFI UPPER ANTENNA FEEDS

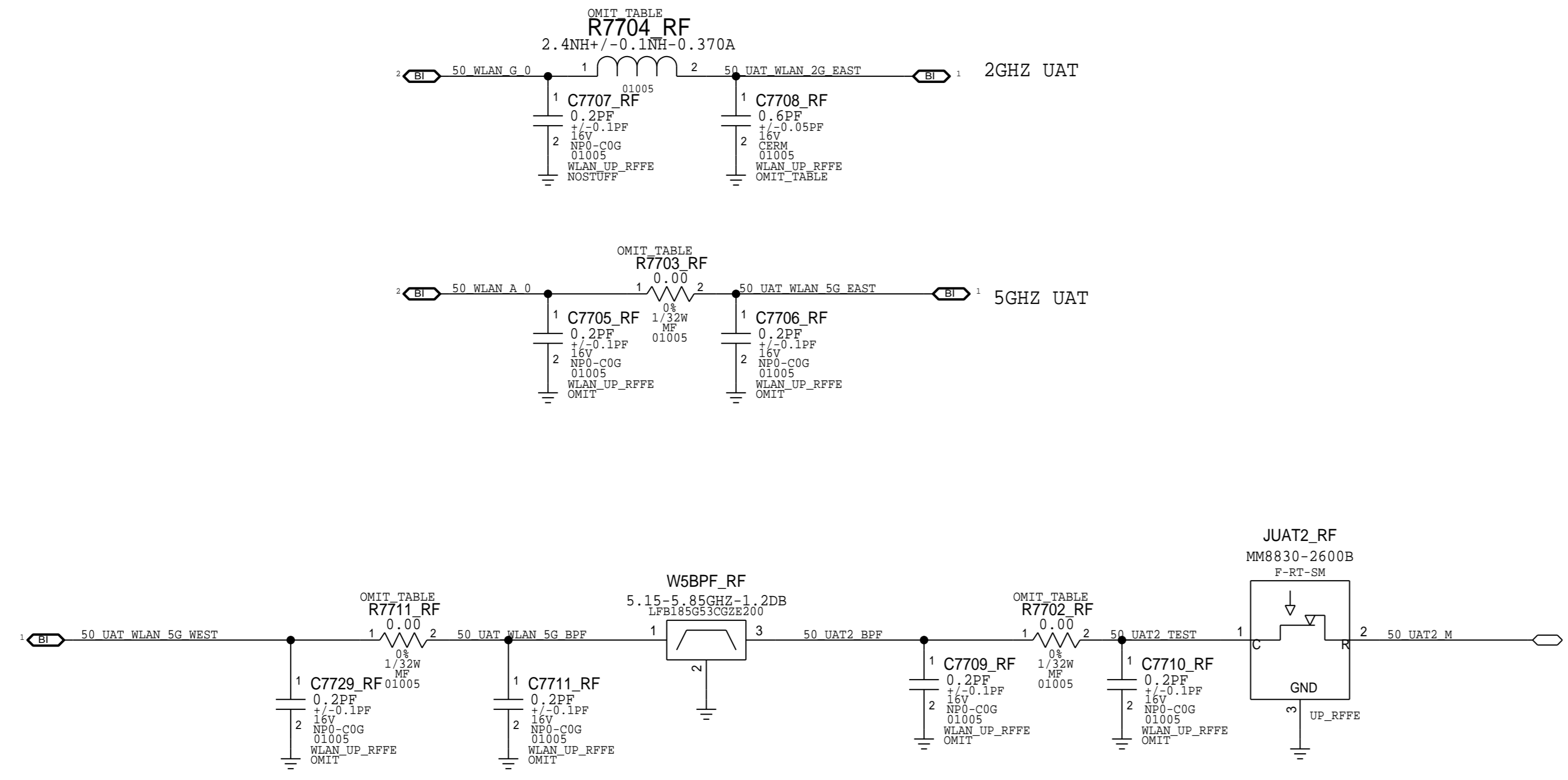

PAGE TITLE		
WIFI FRONT-END [77]		
	DRAWING NUMBER	051-00482
	REVISION	8.0.0
NOTICE OF PROPRIETARY PROPERTY:		
THE INFORMATION CONTAINED HEREIN IS THE PROPRIETARY PROPERTY OF APPLE INC. THE POSSESSOR AGREES TO THE FOLLOWING: I TO MAINTAIN THIS DOCUMENT IN CONFIDENCE II NOT TO REPRODUCE OR COPY IT III NOT TO REVEAL OR PUBLISH IT IN WHOLE OR PART IV ALL RIGHTS RESERVED		
BRANCH	PAGE	77 OF 77
SHEET	61 OF 81	

81 ICEFALL, SIM, DEBUG_CONN
 1. ALL RESISTANCE VALUES ARE IN OHMS, 0.1 WATT +/- 5%.
 2. ALL CAPACITANCE VALUES ARE IN MICROFARADS.
 3. ALL CRYSTALS & OSCILLATOR VALUES ARE IN HERTZ.

REV	ECN	DESCRIPTION OF REVISION	CK APPD	DATE
8	0006532879	ENGINEERING RELEASED		2016-07-06

MAV16 RADIO_MLB

LAST_MODIFICATION=Wed Jun 29 12:06:01 2016

PAGE	CSA	CONTENTS	SYNC	DATE
62	1	page1	<SYNC_MASTER1>	<SYNC_DATE1>
63	2	BOM_OMIT_TABLE	<SYNC_MASTER2>	<SYNC_DATE2>
64	3	PMU: CONTROL AND CLOCKS	<SYNC_MASTER3>	<SYNC_DATE3>
65	4	PMU: SWITCHERS AND LDOS	<SYNC_MASTER4>	<SYNC_DATE4>
66	5	BASEBAND: POWER2	<SYNC_MASTER5>	<SYNC_DATE5>
67	6	BASEBAND: CONTROL		
68	7	BASEBAND GPIOs		
69	8	TRANSCEIVER0/1: POWER		
70	9	TRANSCEIVER0/1: TX PORTS		
71	10	TRANSCEIVER0/1: PRX PORTS		
72	11	RECEIVE MATCHING		
73	12	LOWER ANTENNA & COUPLERS		
74	13	DIVERSITY RECEIVE ASM'S		
75	14	DIVERSITY RECEIVE LNA'S		
76	15	UPPER ANTENNA FEEDS		
77	16	PMU: ET MODULATOR		
78	17	TEST POINTS & BOOT CONFIG		
79	18	TDD TRANSMIT		
80	19	FDD TRANSMIT		
	20			
	21			
	22			
	23			
	24			
	25			
	26			
	27		<SYNC_DATE27>	
	28			
	29			
	30		<SYNC_DATE30>	

SCH: 951-00964
 BOM: 939-00826

ALTERNATES

PART NUMBER	ALTERNATE FOR PART NUMBER	BOM OPTION	REF DES	COMMENTS:
19780565	19780593	ALTERNATE	Y5501_RF	19P2 MHZ XTAL
19780598	19780593	ALTERNATE	Y5501_RF	19P2 MHZ XTAL
138800101	138800095	ALTERNATE	ALL	TRANSITION CAP
335800013	33580894	ALTERNATE	EPROM_RF	IC EPROM
353800253	353800321	ALTERNATE	SWPMX_RF	IC SWITCH SPDT
155800235	155800234	ALTERNATE	UPPD1_RF	NOLMBRF

ALL:C5616_RF-C5618_RF,C5632_RF-C5634_RF

AP CONNECTIONS

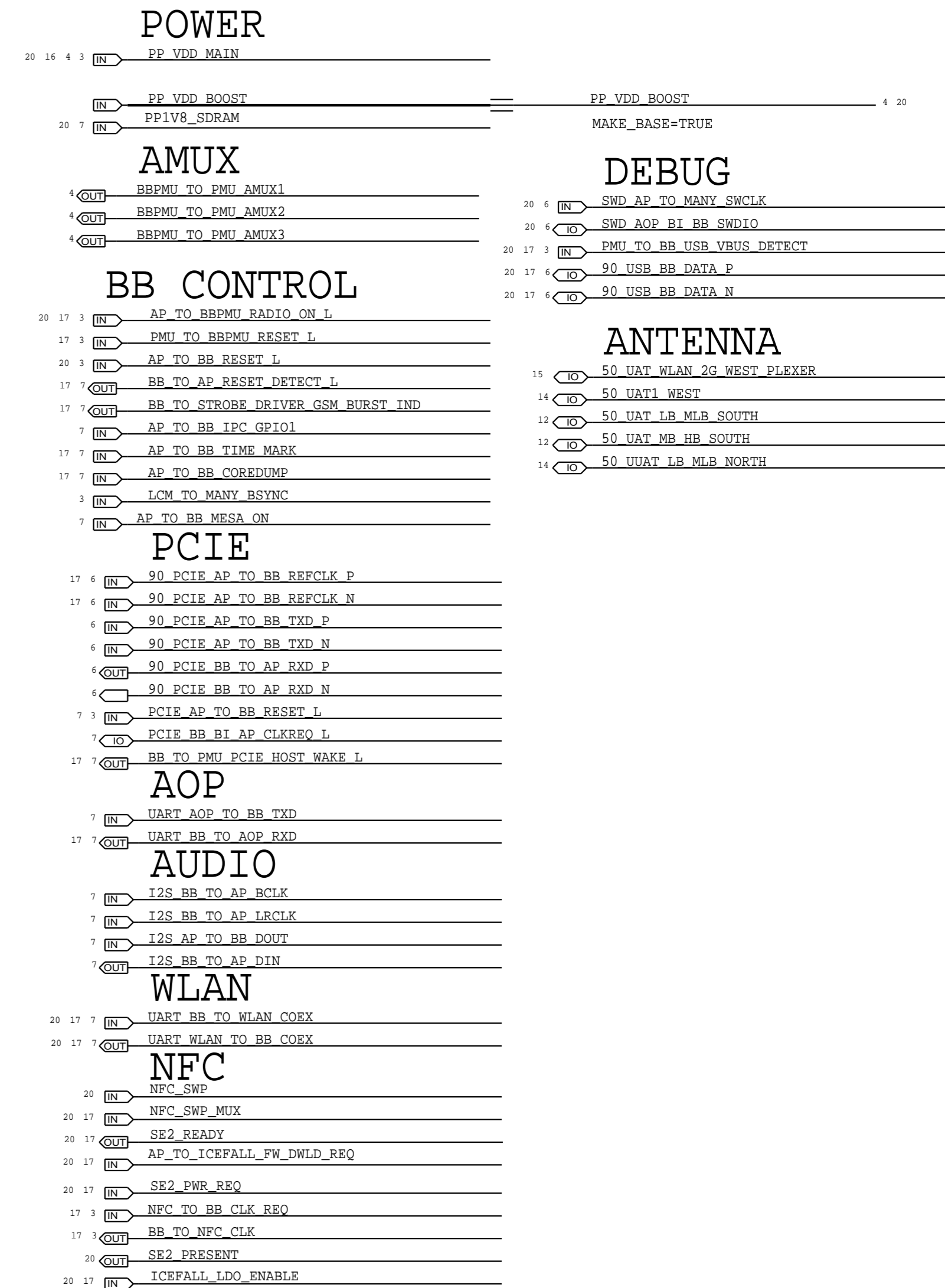

TUNER

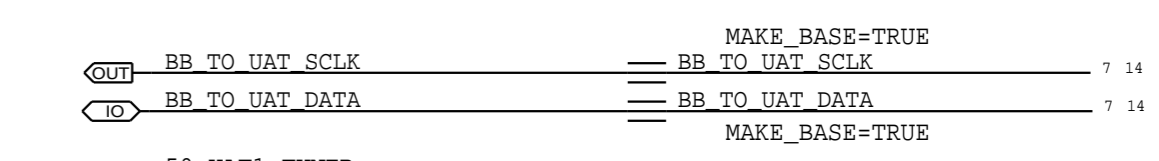

DOCK

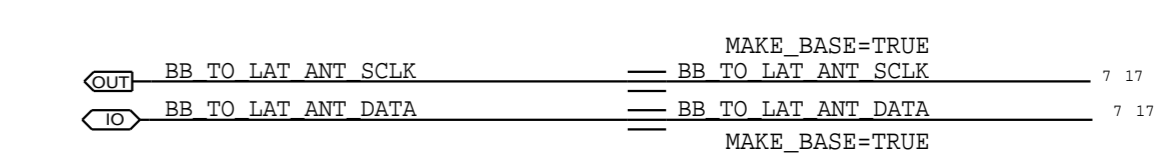

page1

DRAWING TITLE		SCH, MLB, D11	
Apple Inc.	DRAWING NUMBER	051-00482	SIZE
	REVISION	8.0.0	D
NOTICE OF PROPRIETARY PROPERTY: <small>THE INFORMATION CONTAINED HEREIN IS THE PROPRIETARY PROPERTY OF APPLE INC. THE POSSESSOR AGREES TO THE FOLLOWING: I TO MAINTAIN THIS DOCUMENT IN CONFIDENCE II NOT TO REPRODUCE OR COPY IT III NOT TO REVEAL OR PUBLISH IT IN WHOLE OR PART IV ALL RIGHTS RESERVED</small>		BRANCH	
		PAGE	1 OF 72
		SHEET	62 OF 81

BOM OPTIONS:

LMBRF:

PART#	QTY	DESCRIPTION	REFERENCE DESIGNATOR(S)	CRITICAL	BOM OPTION
353800723	1	MLB PAD	MLBPA_RF	CRITICAL	LMBRF
11780002	1	MLB PAD LAT OUTPUT MATCH	R7105_RF	CRITICAL	LMBRF
15282042	1	MLB PAD UAT OUTPUT MATCH	R7106_RF	CRITICAL	LMBRF
353800627	1	MLB IMA	MLBLN_RF	CRITICAL	LMBRF
11780002	1	MLB IMA OUTPUT MATCH	R6710_RF	CRITICAL	LMBRF
155800139	1	PENTAPLEXER	PPLXR_RF	CRITICAL	LMBRF
11880643	1	RES,WF,4.99K,08M,01005	R7506_RF	CRITICAL	LMBRF
155800193	1	FLTR,DIPLEXER,LB-MB-HB,DPX,SHIELD,0805	UATDI_RF	CRITICAL	LMBRF
155800158	1	FLTR,DIPLEXER,LB-MB-HB,MIRROR,0805	UPPDI_RF	CRITICAL	LMBRF
337800284	1	IC,SECURE ELEMENT,BOM02011,ML80A25	SE2_RF	CRITICAL	LMBRF
13880739	1	CAP,10P,0201	C7201_RF	CRITICAL	LMBRF
13880739	1	CAP,10P,0201	C7528_RF	CRITICAL	LMBRF
13280316	1	CAP,0.10P,01005	C7501_RF	CRITICAL	LMBRF
13880739	1	CAP,10P,0201	C7523_RF	CRITICAL	LMBRF
13880739	1	CAP,10P,0201	C7524_RF	CRITICAL	LMBRF
138800032	1	CAP,2.20P,0201	C7529_RF	CRITICAL	LMBRF
138800032	1	CAP,2.20P,0201	C7530_RF	CRITICAL	LMBRF
13180217	1	CAP,1000P,01005	C7531_RF	CRITICAL	LMBRF
11880627	1	RES,10KOHM,01005	R7512_RF	CRITICAL	LMBRF
353800026	1	LDO,REG,2X2	SE2LDO_RF	CRITICAL	LMBRF
13180630	1	CAP,CER,NPO/COG,27PF,2K,16V,01005	C6345_RF	CRITICAL	LMBRF
13180341	1	CAP,CER,COG,3.0PF,+/-0.05,25V,0201,HI-Q	C6348_RF	CRITICAL	LMBRF
15282006	1	IND,FILM,6.2MH,3K,400MA,UH-Q,0201	L6322_RF	CRITICAL	LMBRF
13180630	1	CAP,CER,NPO/COG,27PF,2K,16V,01005	C6315_RF	CRITICAL	LMBRF
15282006	1	IND,FILM,6.2MH,3K,400MA,UH-Q,0201	L6305_RF	CRITICAL	LMBRF
13180341	1	CAP,CER,COG,3.0PF,+/-0.05PF,25V,0201,HI-Q	C6306_RF	CRITICAL	LMBRF
13180630	1	CAP,CER,NPO/COG,27PF,2K,16V,01005	C6106_RF	CRITICAL	LMBRF
15282051	1	IND,1.3NH,1.1A,0201	R6404_RF	CRITICAL	LMBRF
15282000	1	IND,2.0NH,600MA,0201	R7104_RF	CRITICAL	LMBRF
131800001	1	CAP,CER,0.1PF,25V,0201	C7119_RF	CRITICAL	LMBRF
11880724	1	RES,WF,008M,1/20W,0201	R6703_RF	CRITICAL	LMBRF
11880724	1	RES,WF,008M,1/20W,0201	R6708_RF	CRITICAL	LMBRF
13180363	1	CAP,CER,COG,10,0.6PF,+/-0.05PF,25V,0201	C7123_RF	CRITICAL	LMBRF
15282002	1	IND,2.7NH,+/-0.1NH,600MA,0201,UH-Q	R6605_RF	CRITICAL	LMBRF
13180337	1	CAP,1.5PF,+/-0.05PF,25V,0201,HQ	C6610_RF	CRITICAL	LMBRF
11880724	1	RES,WF,008M,1/20W,0201	R6606_RF	CRITICAL	LMBRF
13180275	1	CAP,CER,COG,0.3PF,+/-0.1PF,25V,0201,HQ	C6416_RF	CRITICAL	LMBRF
11880608	1	RES,WF,1K,08M,1/1/32W,01005	R5911_RF	CRITICAL	LMBRF
15281356	1	IND,10NH,3K,250MA,HI-Q,0201	C6613_RF	CRITICAL	LMBRF

NOLMBRF:

PART#	QTY	DESCRIPTION	REFERENCE DESIGNATOR(S)	CRITICAL	BOM OPTION
13180444	1	DCS/PCS RX FILTER MATCH	R6301_RF	CRITICAL	NOLMBRF
15282020	1	DCS/PCS RX FILTER MATCH	L6320_RF	CRITICAL	NOLMBRF
155800149	1	DCS/PCS RX FILTER	GSMRX_RF	CRITICAL	NOLMBRF
15282005	1	DCS/PCS RX MATCH (DCS)	L6318_RF	CRITICAL	NOLMBRF
13180319	1	DCS/PCS RX MATCH (DCS)	C6332_RF	CRITICAL	NOLMBRF
13180630	1	DCS/PCS RX MATCH (DCS)	C6340_RF	CRITICAL	NOLMBRF
15282005	1	DCS/PCS RX MATCH (DCS)	L6319_RF	CRITICAL	NOLMBRF
13180385	1	DCS/PCS RX MATCH (DCS)	C6333_RF	CRITICAL	NOLMBRF
13180630	1	DCS/PCS RX MATCH (DCS)	C6341_RF	CRITICAL	NOLMBRF
155800163	1	QUADPLEXER	PPLXR_RF	CRITICAL	NOLMBRF
155800199	1	FLTR,DPX,PASS THRU,LB-MB-HB,SHLD,0805	UATDI_RF	CRITICAL	NOLMBRF
155800234	1	FLTR,DPX,PASS THRU,LB-MB-HB,UNSHLD,0805	UPPDI_RF	CRITICAL	NOLMBRF
11880724	1	RES,WF,008M,1/20W,0201	R6404_RF	CRITICAL	NOLMBRF
15282044	1	IND,2.2NH,+/-0.1NH,600MA,0201	R7104_RF	CRITICAL	NOLMBRF
152800157	1	1.2NH,+/-0.05NH,1.1A,UH-Q,0201	R6703_RF	CRITICAL	NOLMBRF
13180549	1	18PF,0201,25V	R6708_RF	CRITICAL	NOLMBRF
13180445	1	CAP,CER,12PF,5K,25V,0201,HI-Q	R6606_RF	CRITICAL	NOLMBRF

D10 SPECIFIC:

PART#	QTY	DESCRIPTION	REFERENCE DESIGNATOR(S)	CRITICAL	BOM OPTION
13180278	1	CAP,CER,COG,1PF,+/-0.1PF,25V,0201,HI-Q	C7120_RF	CRITICAL	D10

D11 SPECIFIC:

PART#	QTY	DESCRIPTION	REFERENCE DESIGNATOR(S)	CRITICAL	BOM OPTION
13180425	1	CAP,CER,COG,0.5PF,+/-0.05PF,25V,0201,HI-Q	C7120_RF	CRITICAL	D11

PMU: CONTROL AND CLOCKS

RESET AND CONTROL: PMU

HW_REV_ID	R5505	R5501	REVISION
0.10V	887K	51.1K	DEV1
0.20V	422K	51.1K	DEV2
0.30V	255K	51.1K	DEV 2.1
0.40V	180K	51.1K	DEV 3
0.50V	124K	51.1K	T181
0.60V	102K	51.1K	PP/P1
0.70V	82.5K	51.1K	DEV4
0.80V	63.4K	51.1K	P2
0.90V	51.1K	51.1K	DEV5
1.00V	51.1K	63.4K	EVT
1.10V	51.1K	82.5K	EVT DOE
1.20V	50.0K	100K	EVT ALT/CARBON
1.30V	39.0K	100K	DEV6
1.40V	14.7K	51.1K	CARRIER
1.50V	40.2K	200K	DVT
1.60V	6.34K	51.1K	PVT

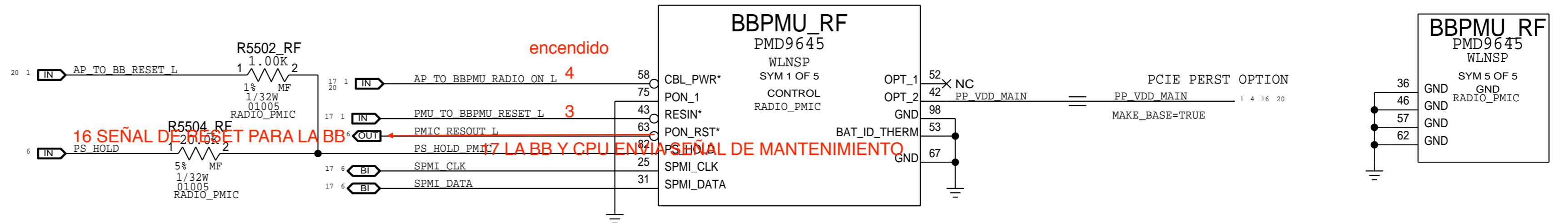

MPPS AND GPIOs: PMU

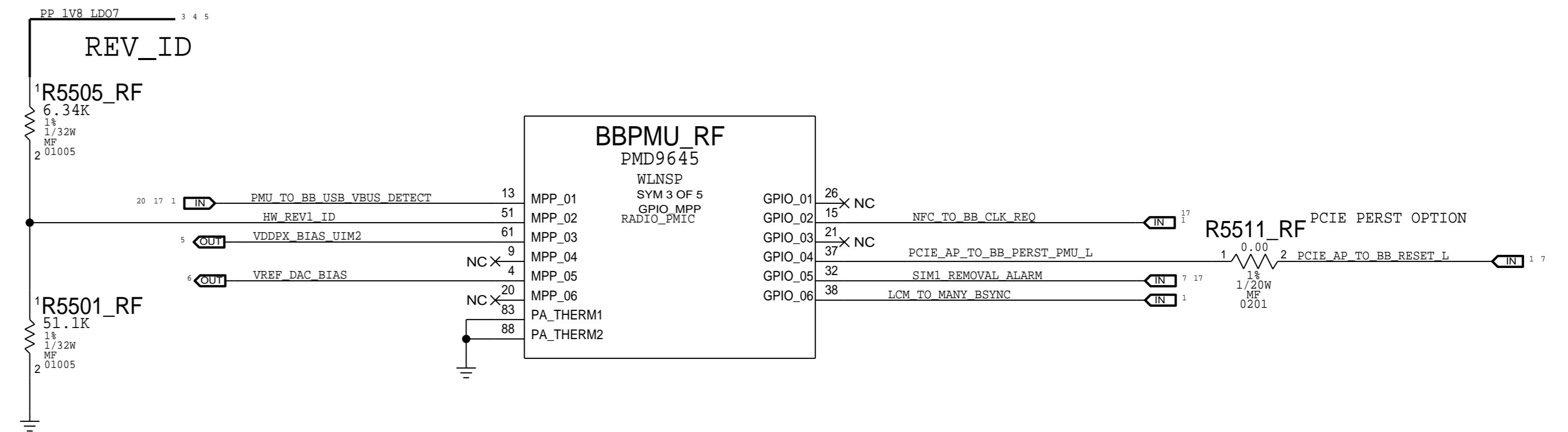

XTAL AND CLOCK: PMU

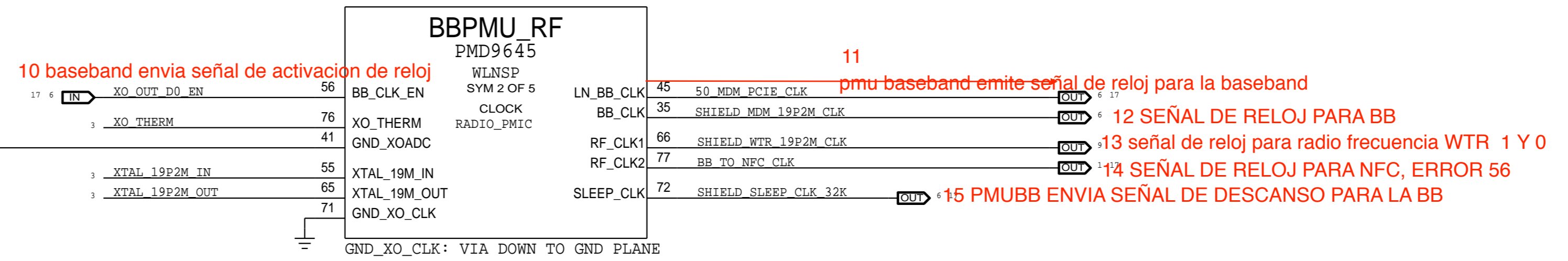
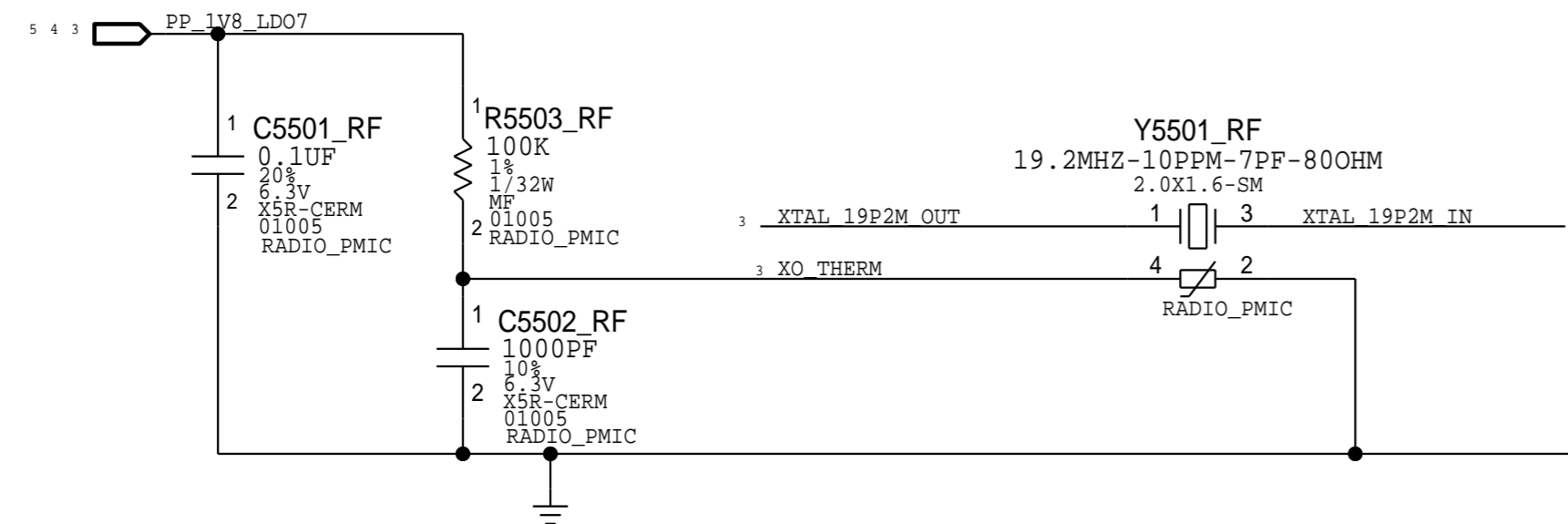

PAGE TITLE		DRAWING NUMBER		SIZE
PAGE_TITLE=PMU: CONTROL AND CLOCKS		051-00482		D
REVISION		8.0.0		
BRANCH				
PAGE		55 OF 72		
SHEET		64 OF 81		

PMU: SWITCHERS AND LDOS

SWITCHERS BULK CAPS

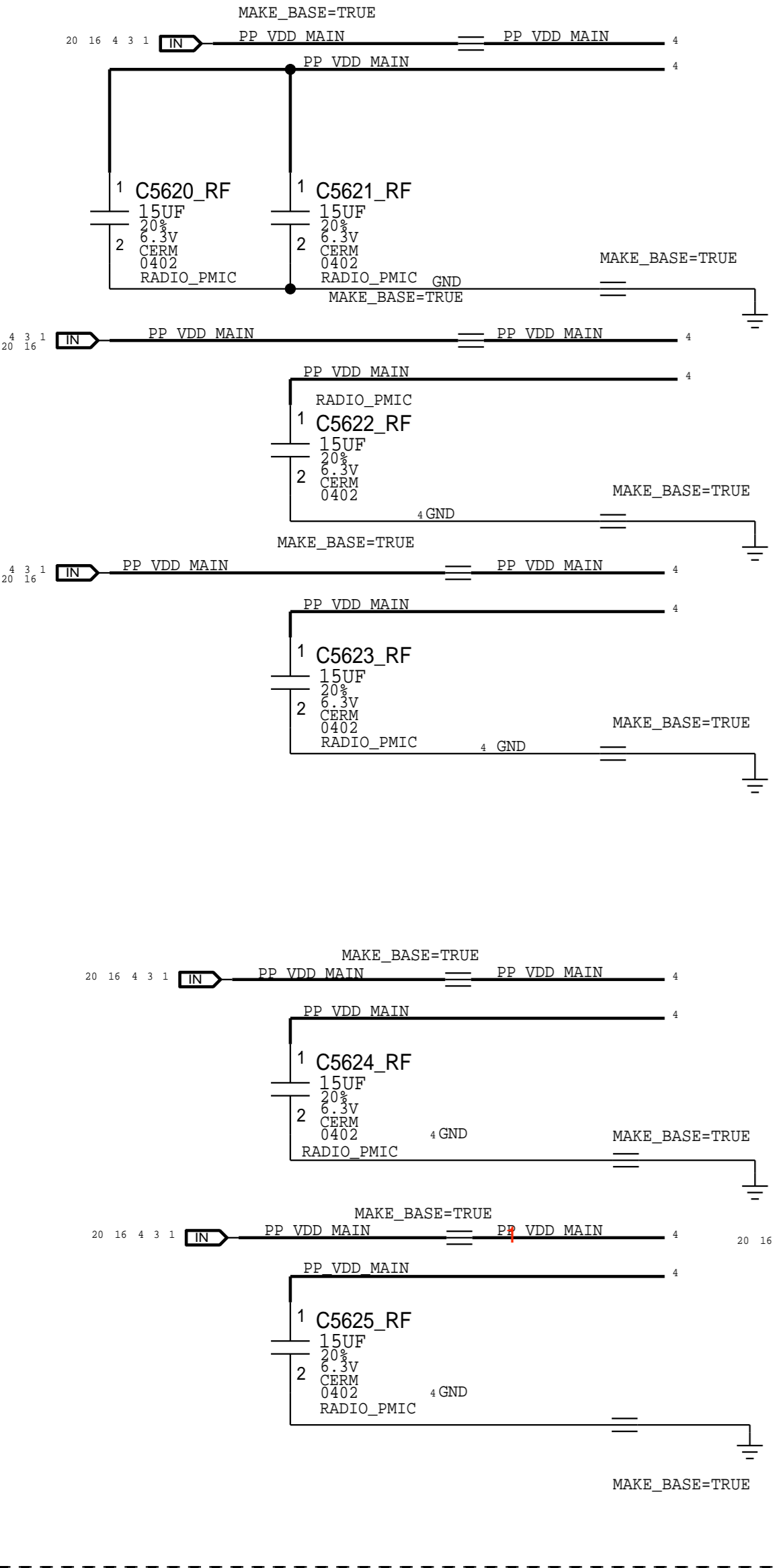

DESENSE CAPS

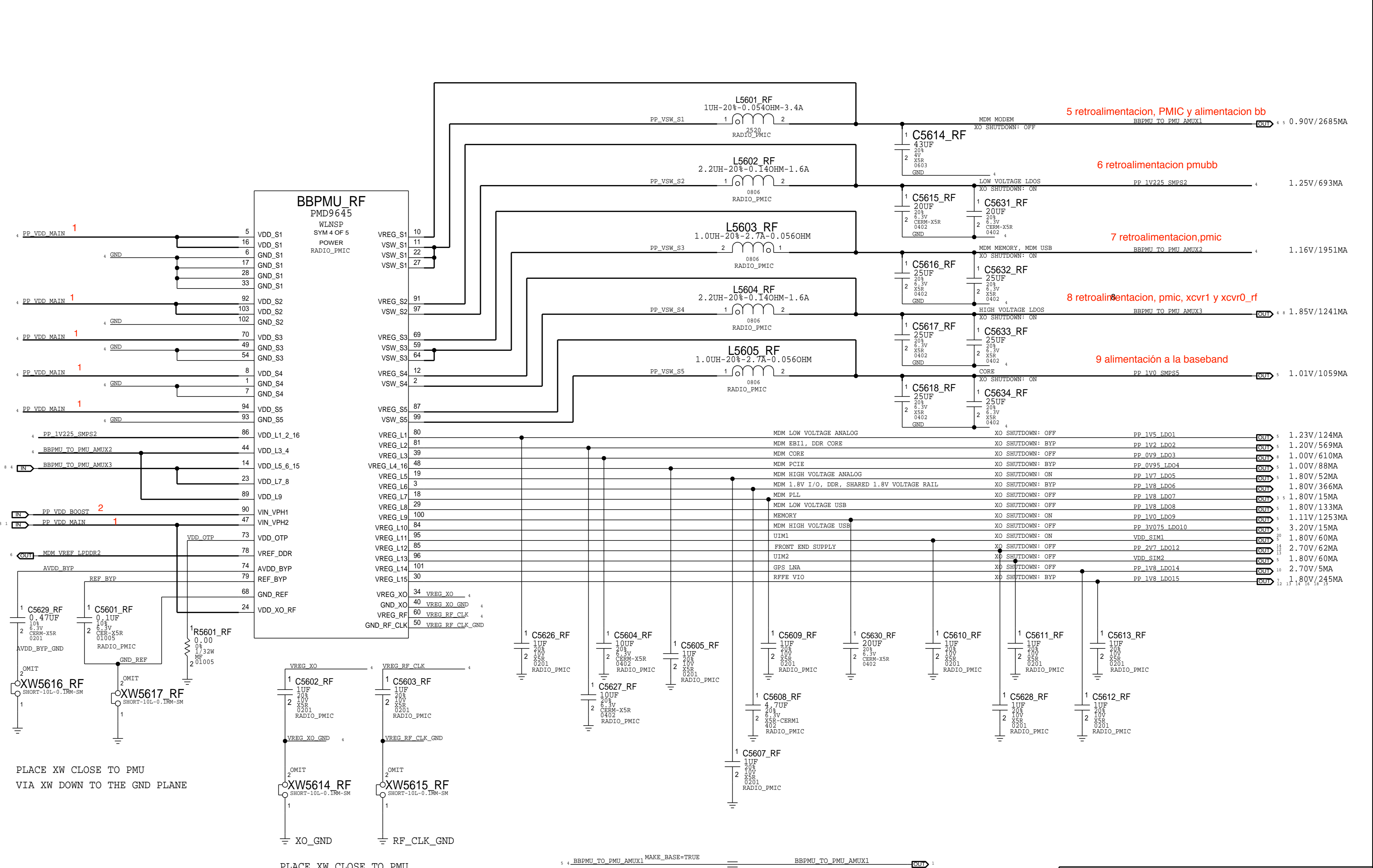
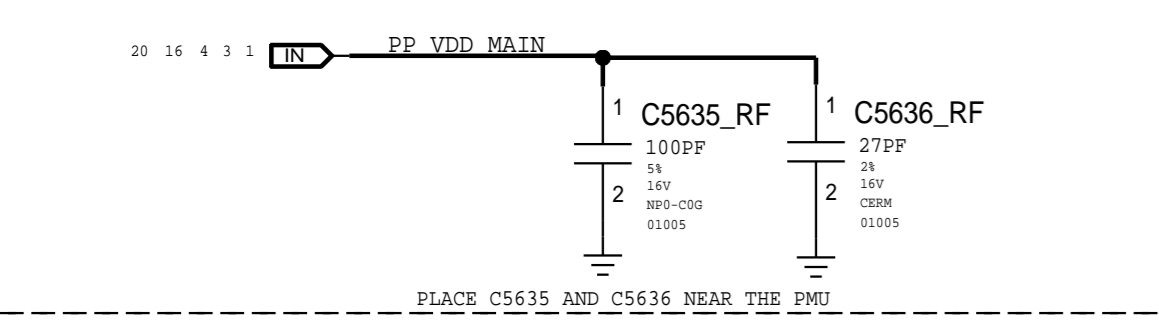

PLACE XW CLOSE TO PMU
VIA XW DOWN TO THE GND PLANE

PLACE XW CLOSE TO PMU
VIA XW DOWN TO THE GND PLANE

PAGE TITLE		PAGE_TITLE=PMU: SWITCHERS AND LDOS	
DRAWING NUMBER		051-00482	
REVISION		8.0.0	
BRANCH			
PAGE		56 OF 72	
SHEET		65 OF 81	

NOTICE OF PROPRIETARY PROPERTY:
THE INFORMATION CONTAINED HEREIN IS THE PROPRIETARY PROPERTY OF APPLE INC. THE POSSESSOR AGREES TO THE FOLLOWING:
I TO MAINTAIN THIS DOCUMENT IN CONFIDENCE
II NOT TO REPRODUCE OR COPY IT
III NOT TO REVEAL OR PUBLISH IT IN WHOLE OR PART
IV ALL RIGHTS RESERVED

BASEBAND: POWER

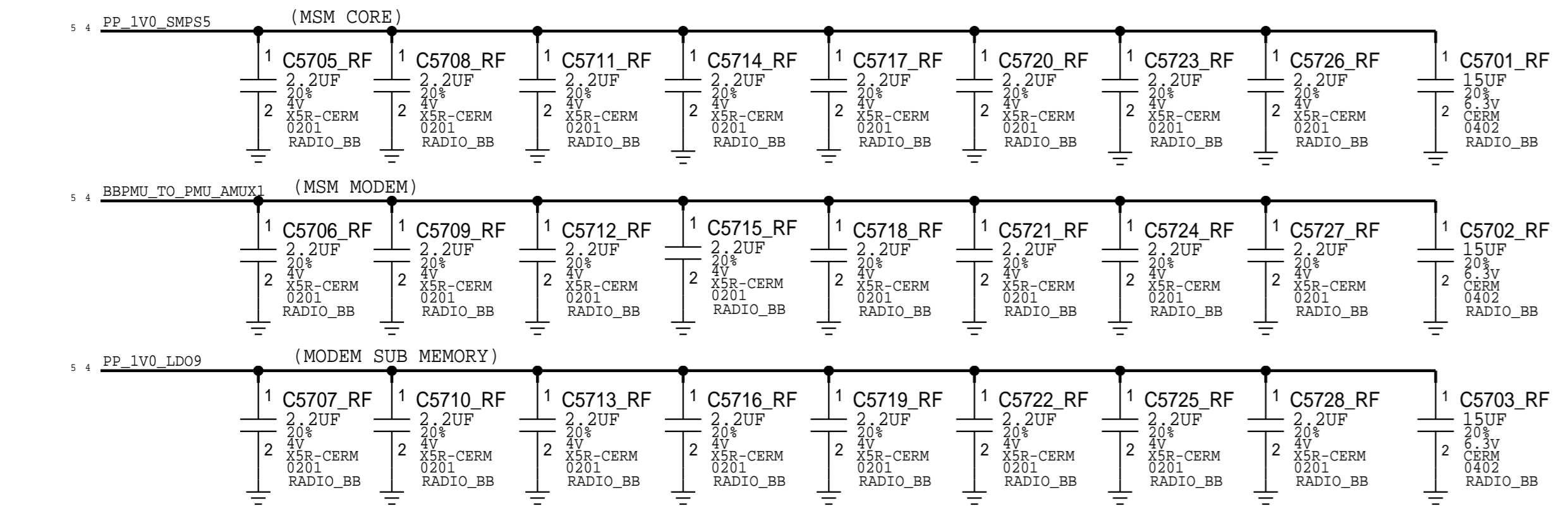
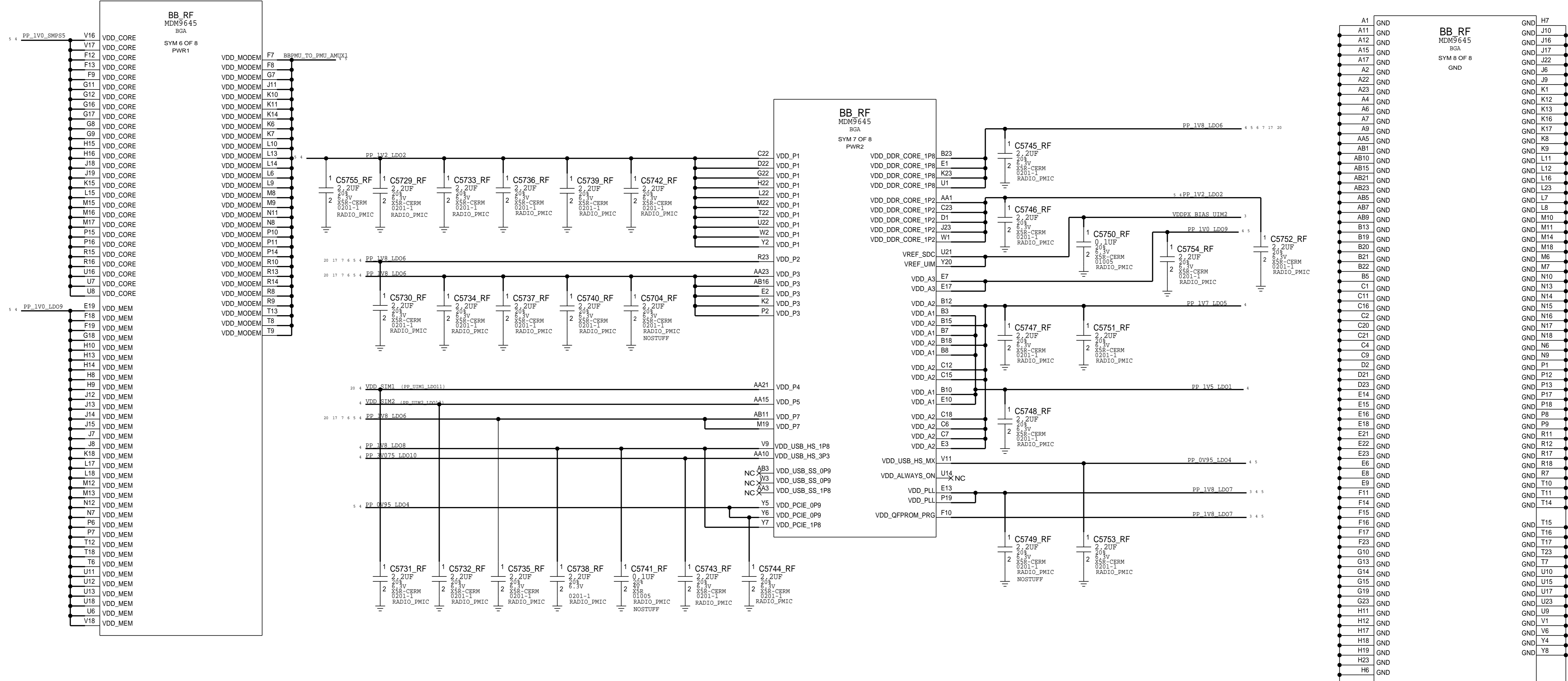

CONFIDENTIAL AND PROPRIETARY APPLE SYSTEM DESIGN. FOR REFERENCE PURPOSE ONLY - NOT A CHANGE REQUEST

PAGE TITLE PAGE_TITLE=BASEBAND: POWER2		DRAWING NUMBER 051-00482		SIZE D
Apple Inc.		REVISION 8.0.0		BRANCH
NOTICE OF PROPRIETARY PROPERTY: THE INFORMATION CONTAINED HEREIN IS THE PROPRIETARY PROPERTY OF APPLE INC. THE POSSESSOR AGREES TO THE FOLLOWING: I TO MAINTAIN THIS DOCUMENT IN CONFIDENCE II NOT TO REPRODUCE OR COPY IT III NOT TO REVEAL OR PUBLISH IT IN WHOLE OR PART IV ALL RIGHTS RESERVED		PAGE 57 OF 72		SHEET 66 OF 81

BASEBAND: CONTROL AND INTERFACES

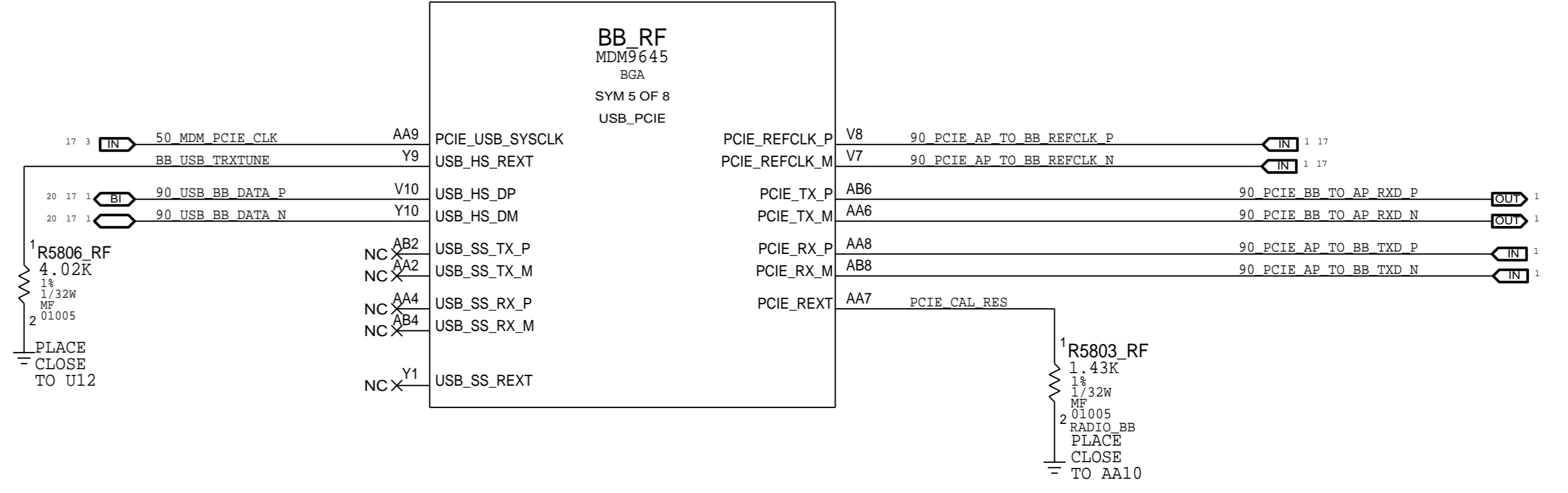
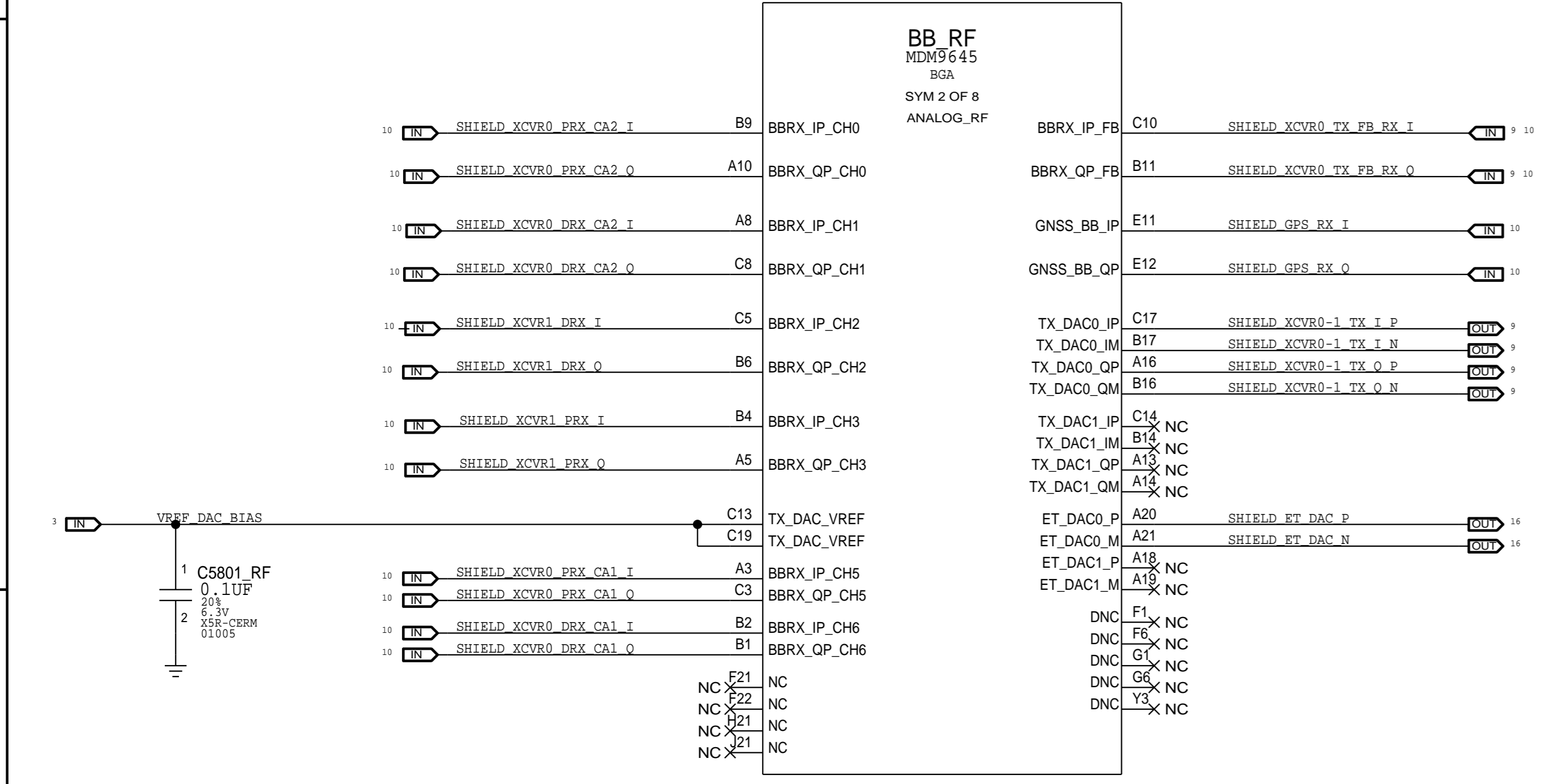
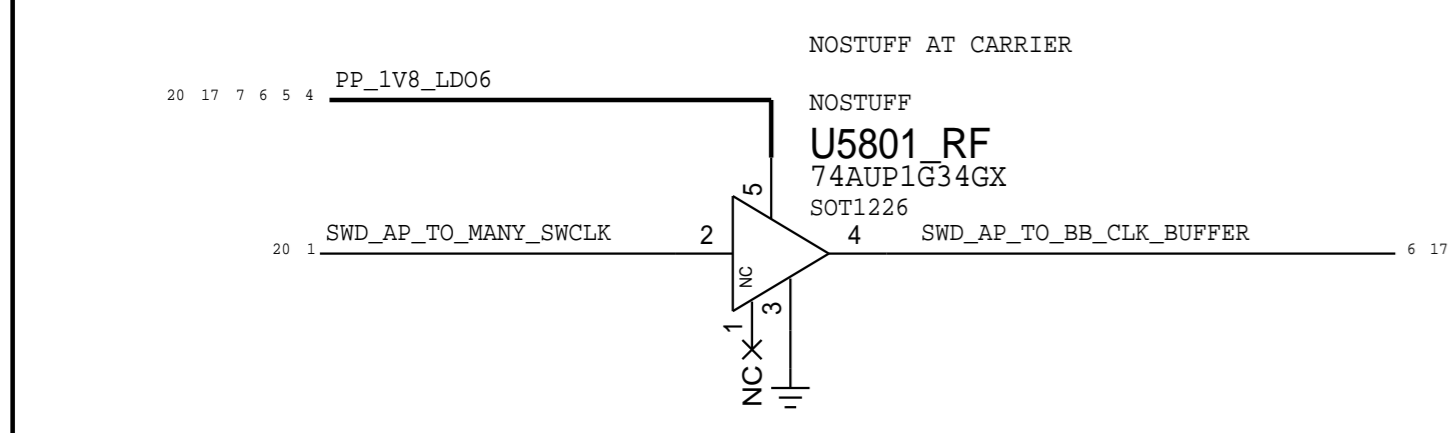
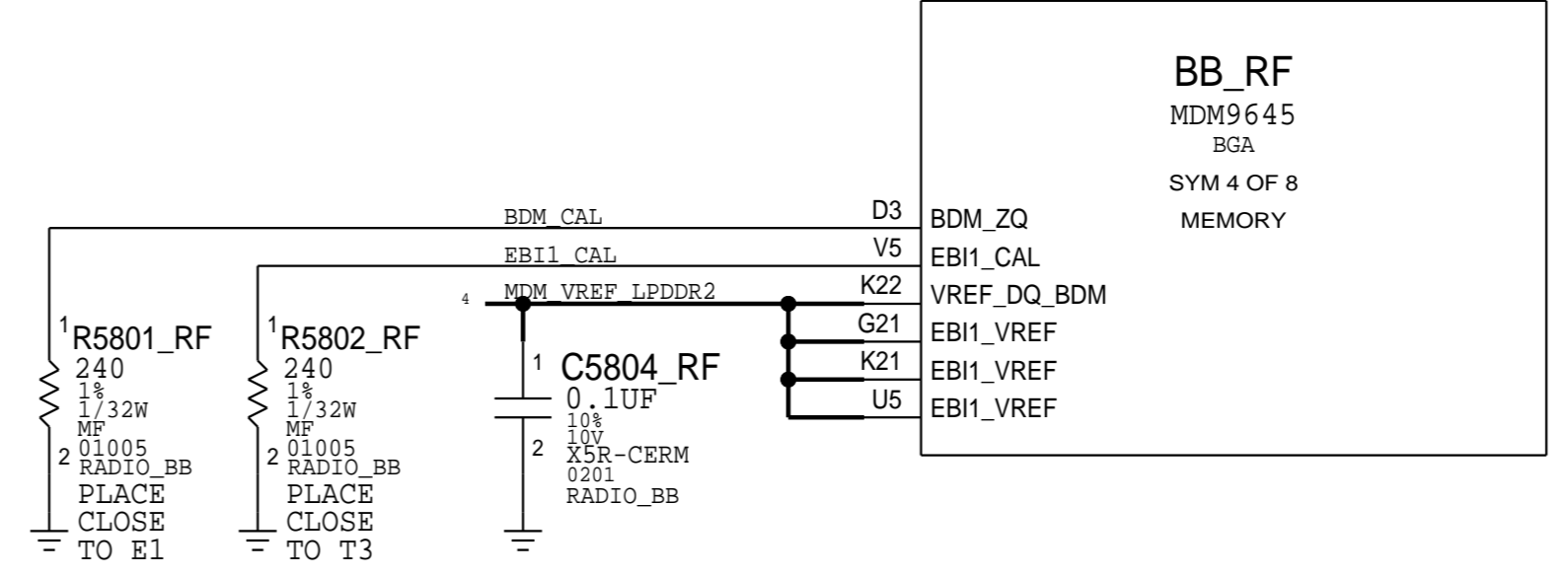
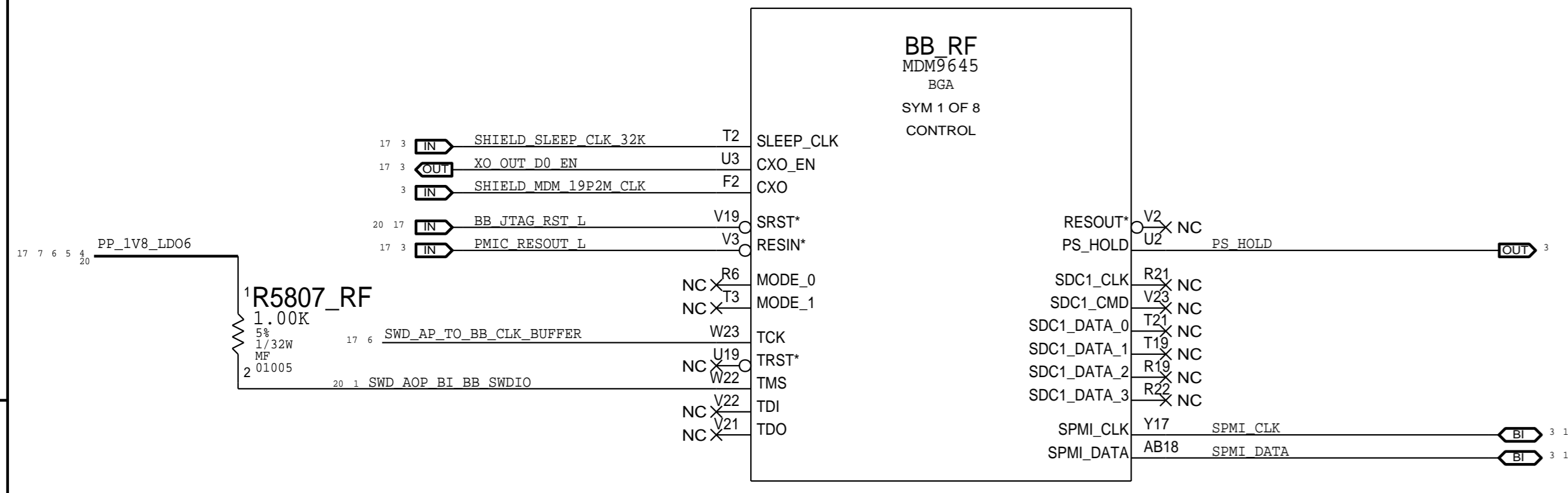

PAGE TITLE		DRAWING NUMBER		SIZE
PAGE_TITLE=BASEBAND: CONTROL		051-00482		D
REVISION		8.0.0		
BRANCH				
PAGE		58 OF 72		
SHEET		67 OF 81		

BASEBAND: GPIOS

SKU	R5911_RF	R5912_RF
ROW	NOSTUFF	NOSTUFF
JP	1.0 KOHM	NOSTUFF

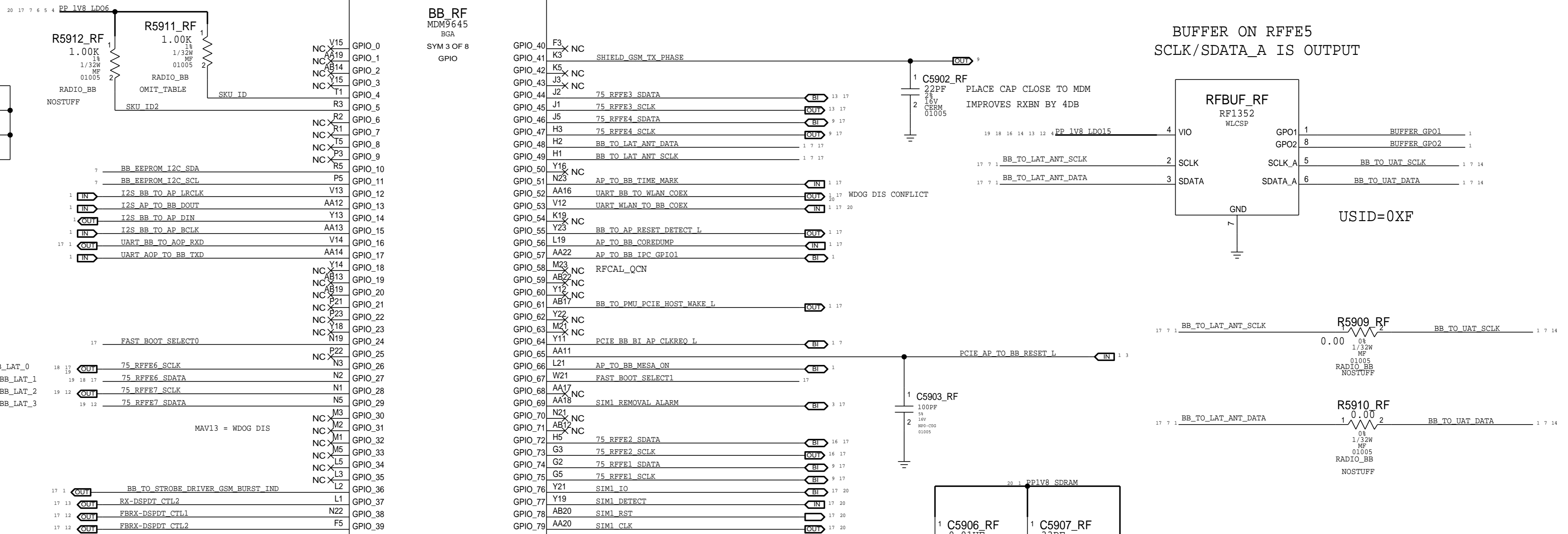

RFFE USAGE TABLE

- RFFE1 WTR3925
- RFFE2 QFE3100
- RFFE3 DIV MODULES
- RFFE4 WTR4905
- RFFE5 TUNERS + ELNAS
- RFFE6 2G PA, MLB PA, MB/HB TDD PA, MB/HB FDD PA
- RFFE7 LB PA, COUPLERS

PCIE PULL-UPS TO BB RAIL

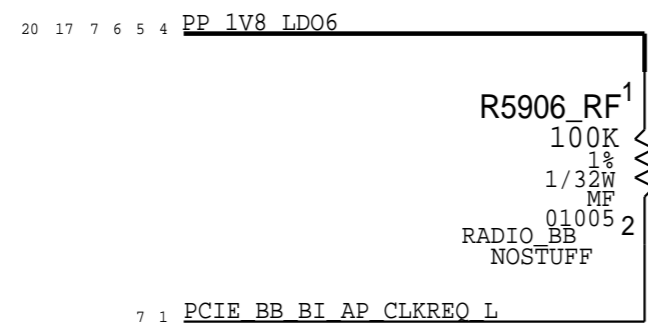

BB EEPROM

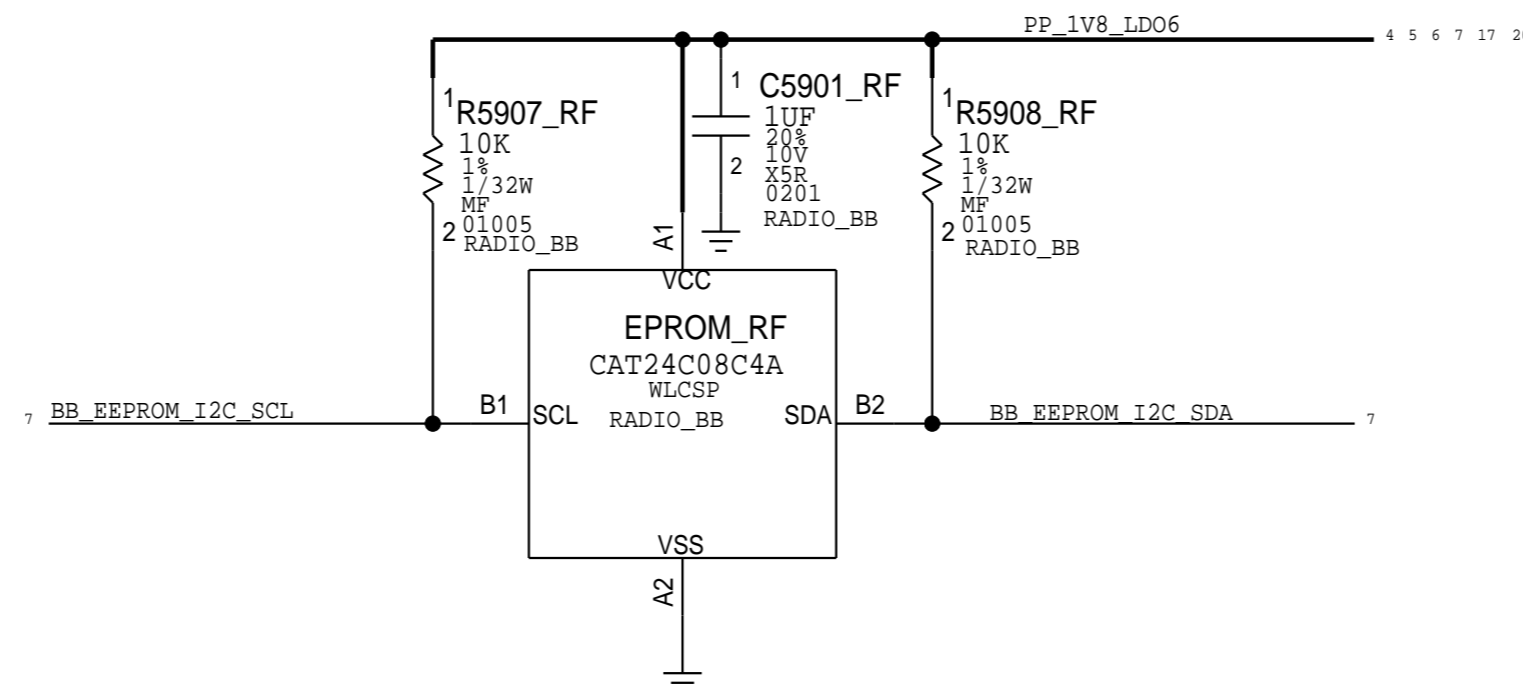

CONFIDENTIAL AND PROPRIETARY APPLE SYSTEM DESIGN. FOR REFERENCE PURPOSE ONLY - NOT A CHANGE REQUEST

PAGE TITLE		DRAWING NUMBER		SIZE
BASEBAND GPIOS		051-00482	D	
Apple Inc.		REVISION		8.0.0
NOTICE OF PROPRIETARY PROPERTY:		BRANCH		
THE INFORMATION CONTAINED HEREIN IS THE PROPRIETARY PROPERTY OF APPLE INC. THE POSSESSOR AGREES TO THE FOLLOWING:		PAGE		59 OF 72
I TO MAINTAIN THIS DOCUMENT IN CONFIDENCE		SHEET		68 OF 81
II NOT TO REPRODUCE OR COPY IT				
III NOT TO REVEAL OR PUBLISH IT IN WHOLE OR PART				
IV ALL RIGHTS RESERVED				

TRANSCEIVER: POWER

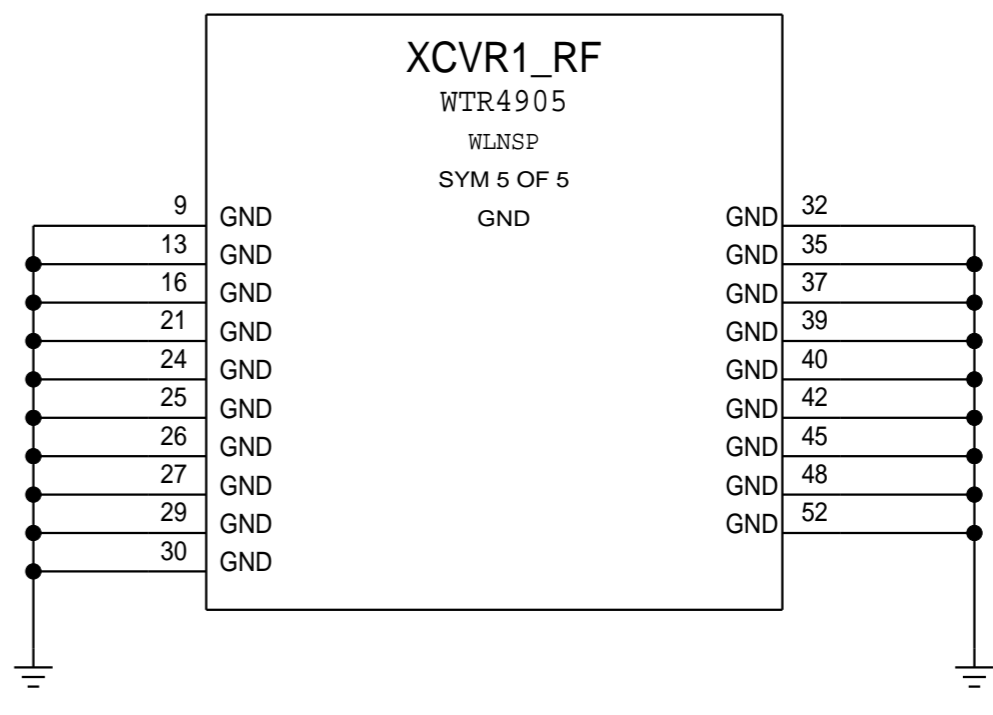
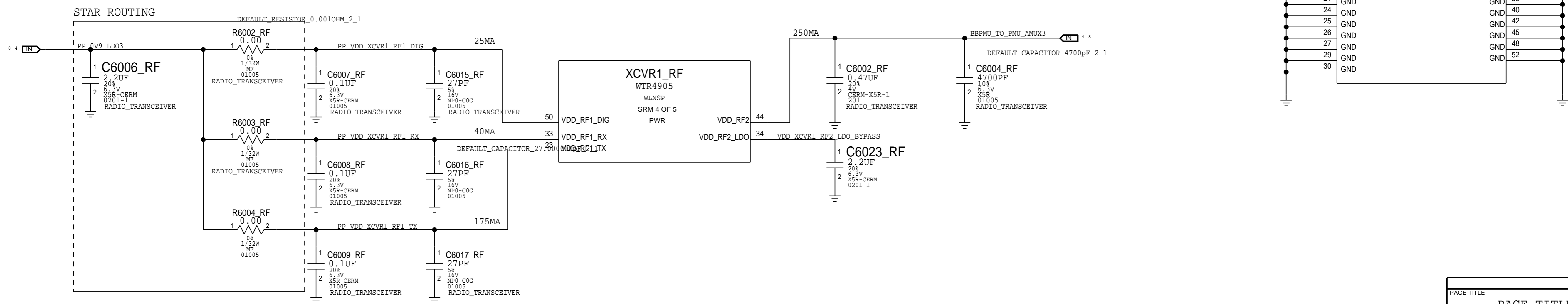
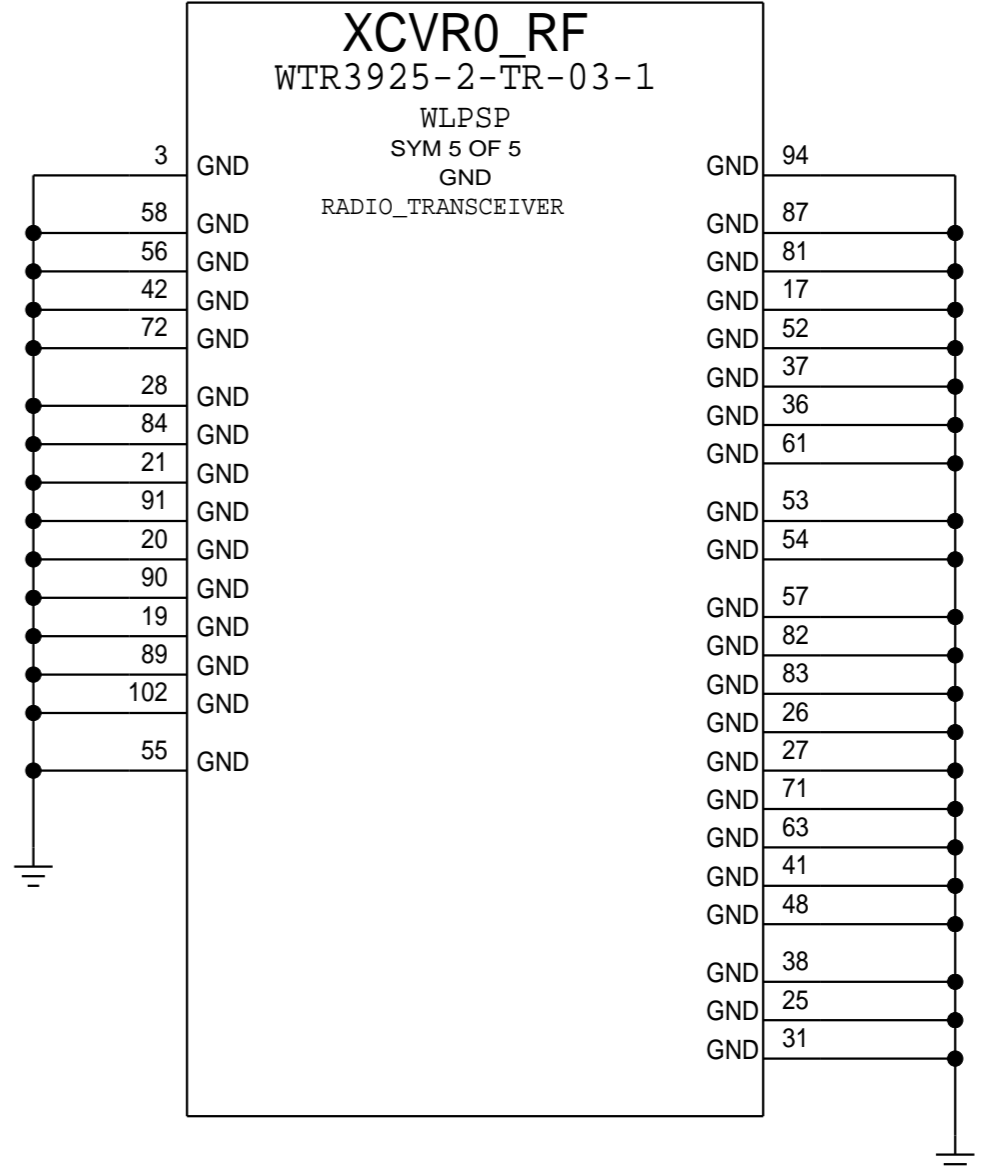
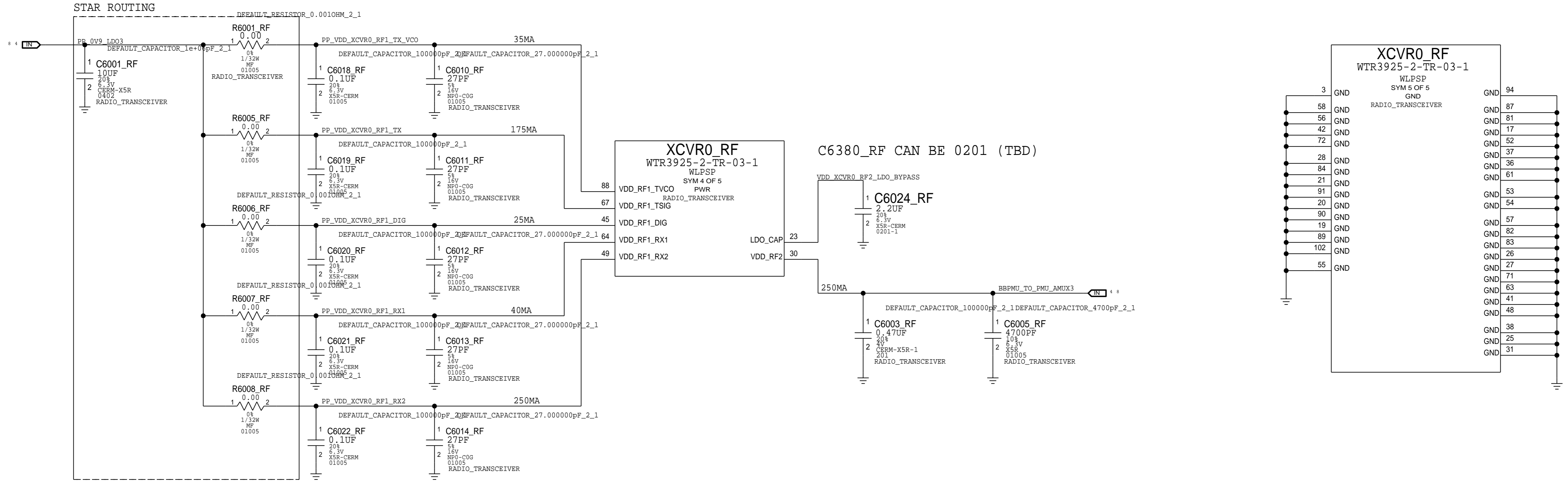

PAGE TITLE			PAGE_TITLE=TRANSCEIVER0/1: POWER		
DRAWING NUMBER		051-00482	REVISION		8.0.0
NOTICE OF PROPRIETARY PROPERTY:		THE INFORMATION CONTAINED HEREIN IS THE PROPRIETARY PROPERTY OF APPLE INC. THE POSSESSOR AGREES TO THE FOLLOWING: I TO MAINTAIN THIS DOCUMENT IN CONFIDENCE II NOT TO REPRODUCE OR COPY IT III NOT TO REVEAL OR PUBLISH IT IN WHOLE OR PART IV ALL RIGHTS RESERVED			
BRANCH		60 OF 72			
PAGE		69 OF 81			
SHEET		69 OF 81			

TRANSCIEVER: TX PORTS

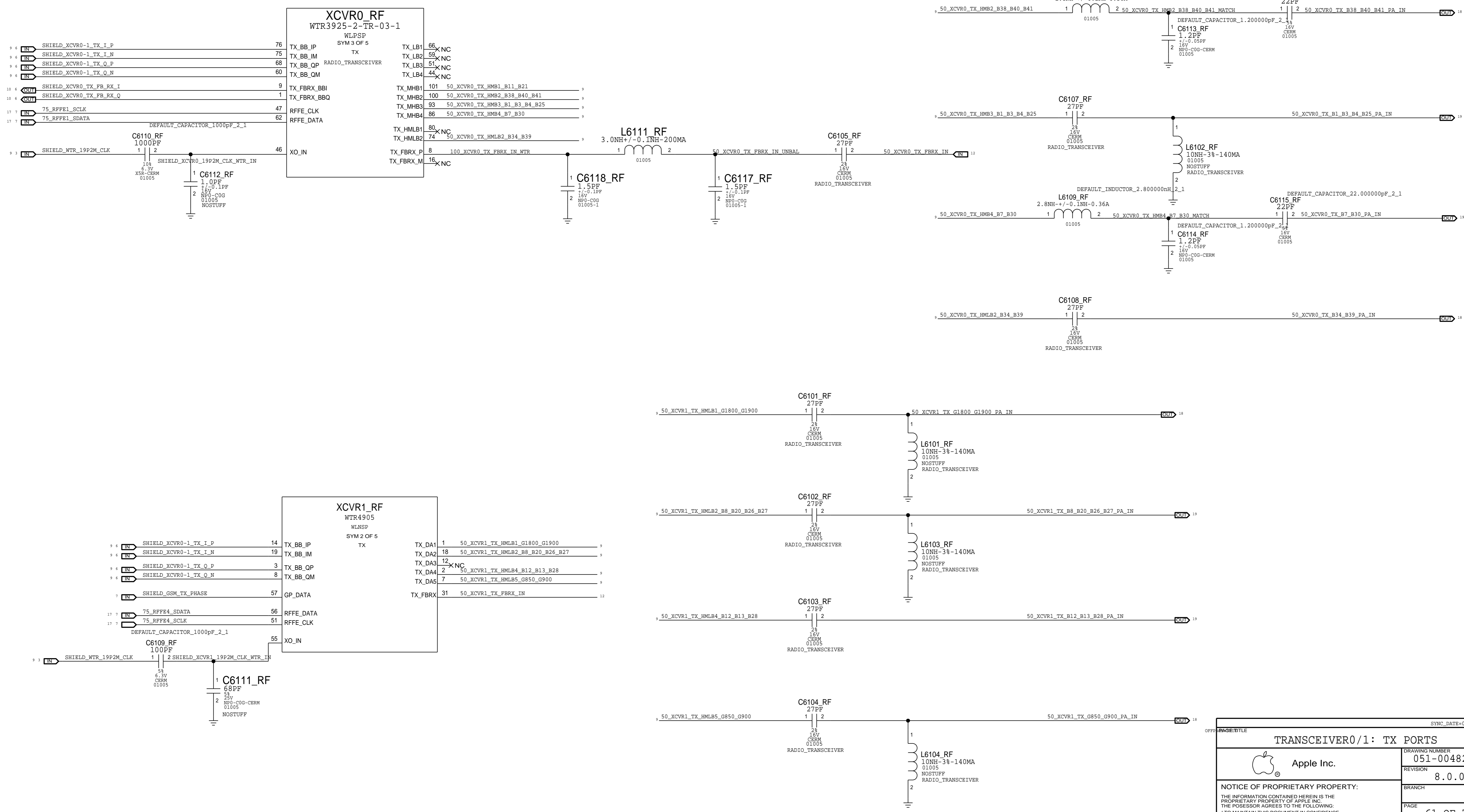

CONFIDENTIAL AND PROPRIETARY APPLE SYSTEM DESIGN. FOR REFERENCE PURPOSE ONLY - NOT A CHANGE REQUEST

PAGE/TITLE		TRANSCEIVER0/1: TX PORTS	
Apple Inc.	DRAWING NUMBER	051-00482	SIZE
	REVISION	8.0.0	D
NOTICE OF PROPRIETARY PROPERTY: THE INFORMATION CONTAINED HEREIN IS THE PROPRIETARY PROPERTY OF APPLE INC. THE POSSESSOR AGREES TO THE FOLLOWING: I TO MAINTAIN THIS DOCUMENT IN CONFIDENCE II NOT TO REPRODUCE OR COPY IT III NOT TO REVEAL OR PUBLISH IT IN WHOLE OR PART IV ALL RIGHTS RESERVED		BRANCH	
		PAGE	61 OF 72
		SHEET	70 OF 81

TRANSCEIVER: PRX, DRX, & GPS PORTS

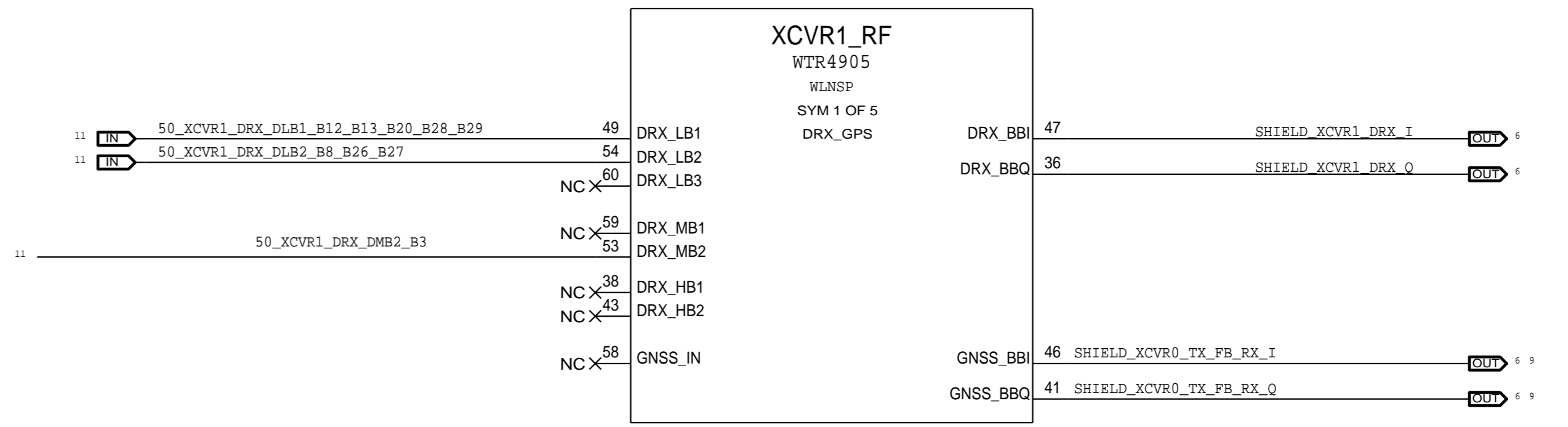
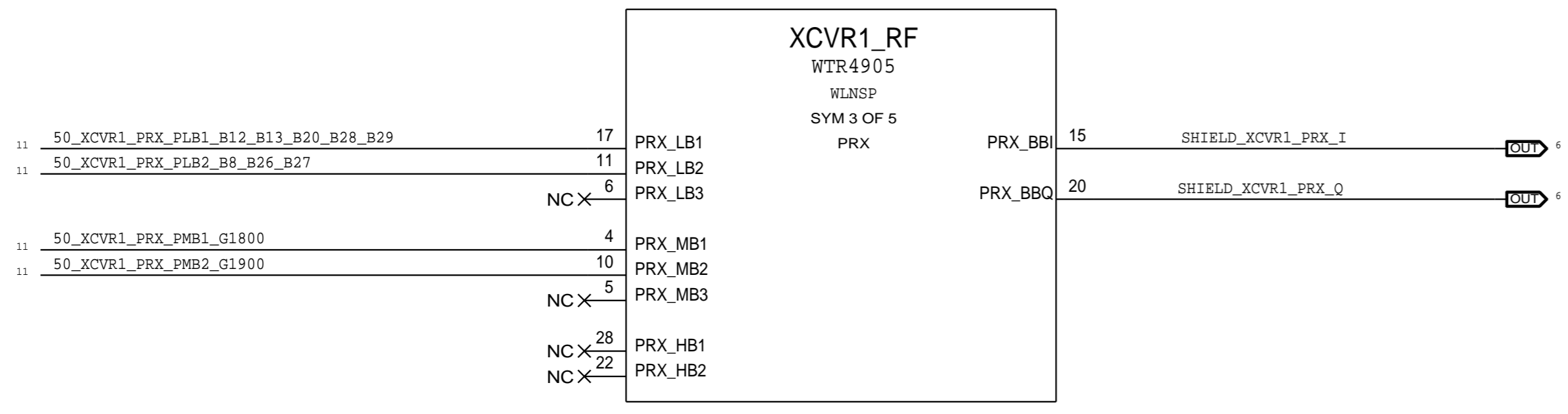
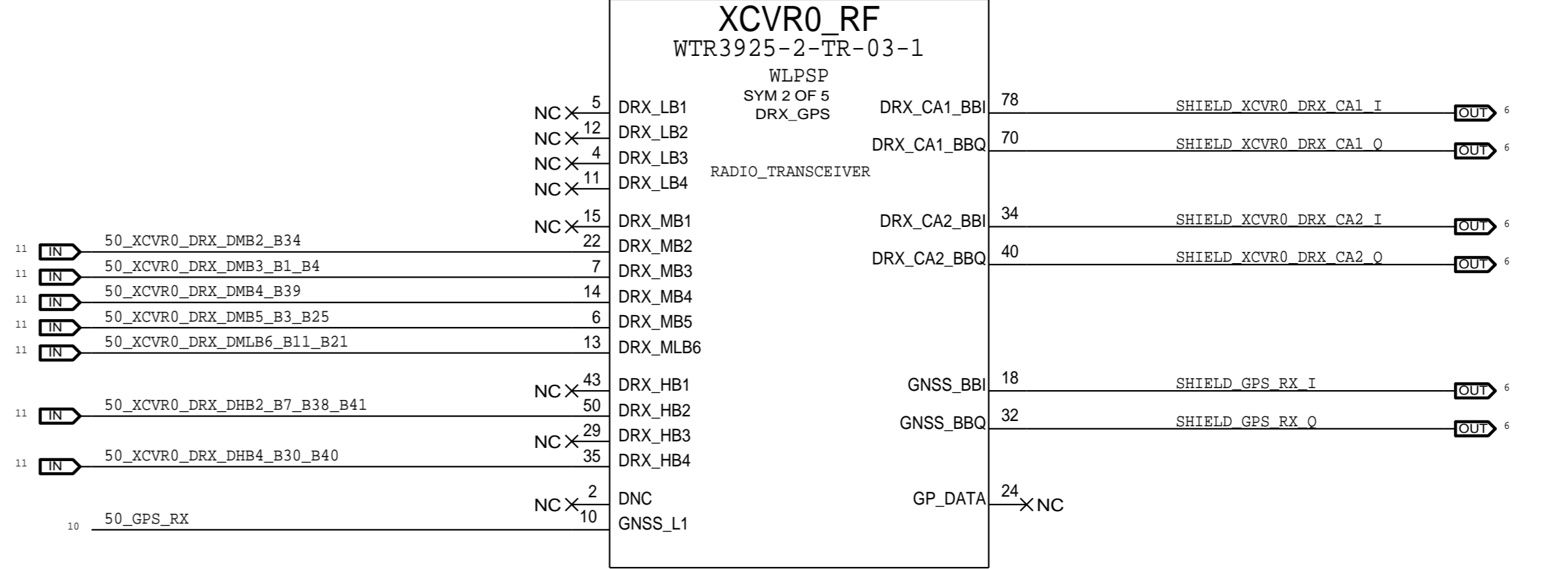
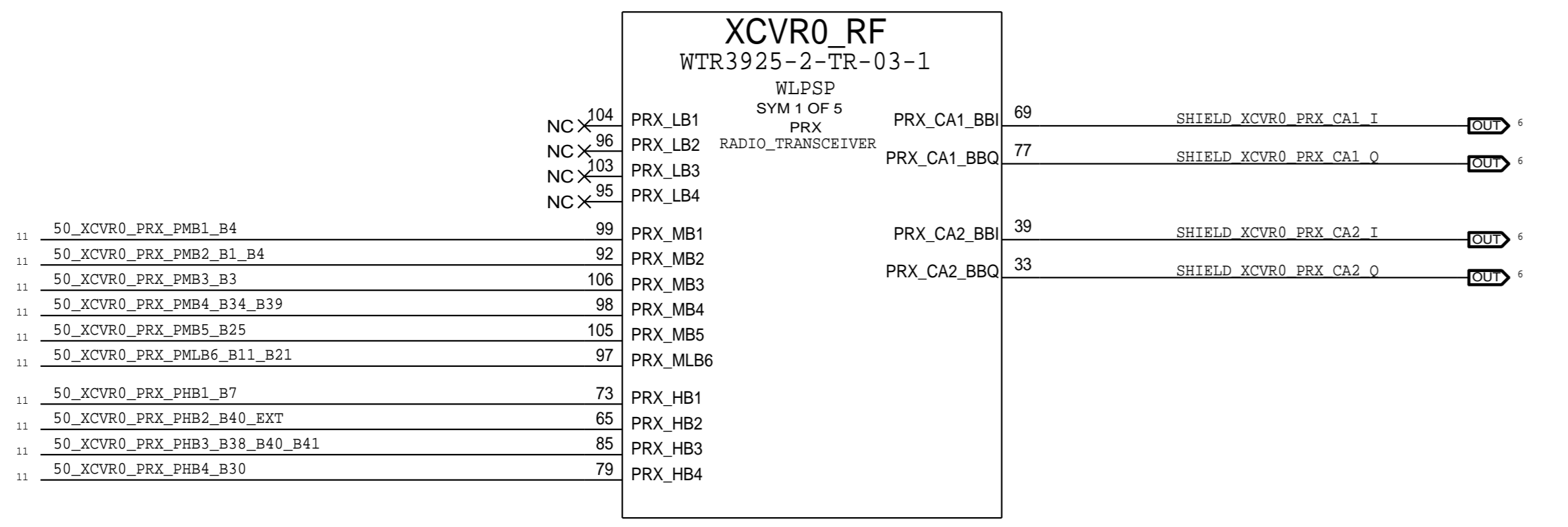

GPS FILTER PLACE NEAR U_WTR

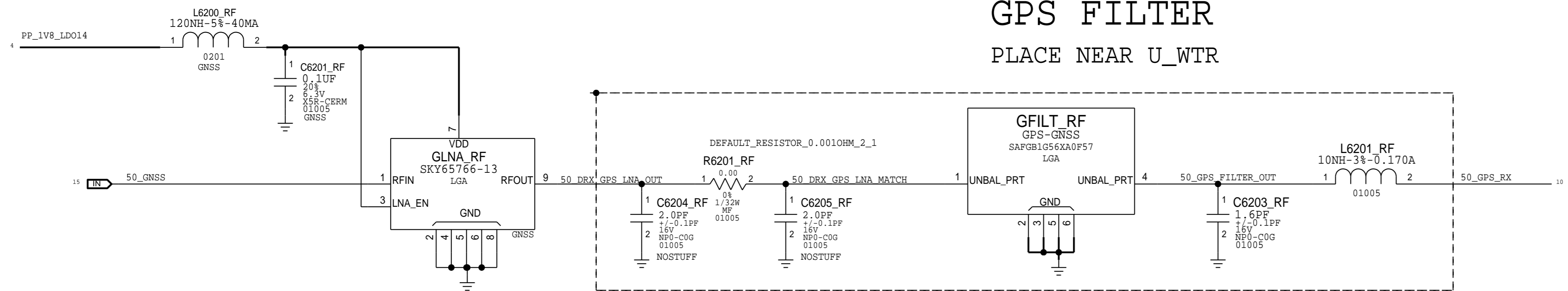

PAGE TITLE		SYNC_DATE=04/17/2015	
PAGE_TITLE=TRANSCEIVER0/1: PRX PORTS		DRAWING NUMBER	SIZE
Apple Inc.		051-00482	D
REVISION		8.0.0	
NOTICE OF PROPRIETARY PROPERTY:		BRANCH	
THE INFORMATION CONTAINED HEREIN IS THE PROPRIETARY PROPERTY OF APPLE INC. THE POSSESSOR AGREES TO THE FOLLOWING:		PAGE	
I TO MAINTAIN THIS DOCUMENT IN CONFIDENCE		62 OF 72	
II NOT TO REPRODUCE OR COPY IT		SHEET	
III NOT TO REVEAL OR PUBLISH IT IN WHOLE OR PART		71 OF 81	
IV ALL RIGHTS RESERVED			

PRIMARY & DIVERSITY RECEIVE MATCHING

DC BLOCKING CAP VALUES CANNOT BE MORE THAN 33PF

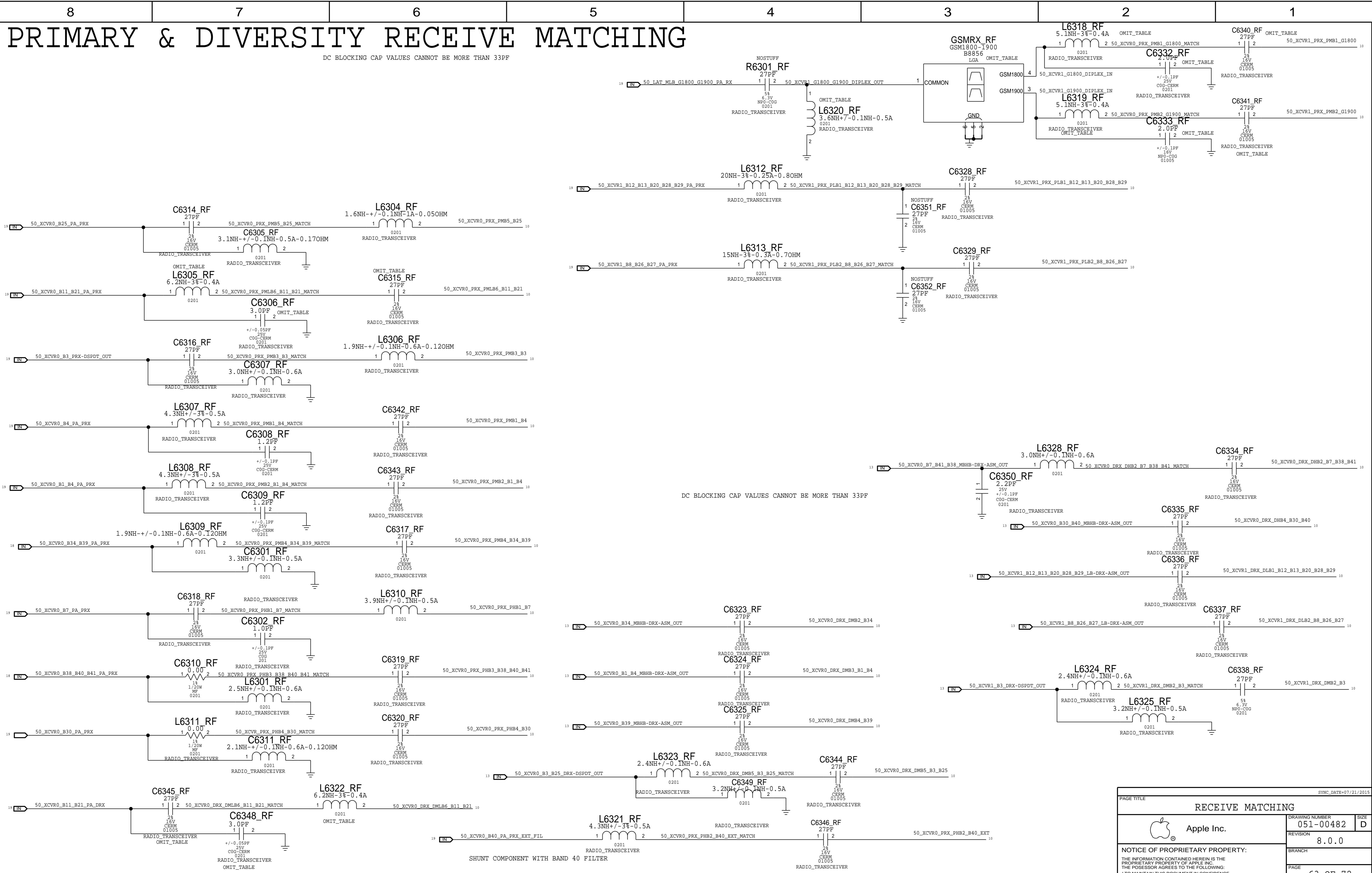

DC BLOCKING CAP VALUES CANNOT BE MORE THAN 33PF

SHUNT COMPONENT WITH BAND 40 FILTER

PAGE TITLE		RECEIVE MATCHING	
DRAWING NUMBER		051-00482	
REVISION		8.0.0	
BRANCH		63 OF 72	
PAGE		72 OF 81	
SHEET			

NOTICE OF PROPRIETARY PROPERTY:
 THE INFORMATION CONTAINED HEREIN IS THE PROPRIETARY PROPERTY OF APPLE INC. THE POSSESSOR AGREES TO THE FOLLOWING:
 I TO MAINTAIN THIS DOCUMENT IN CONFIDENCE
 II NOT TO REPRODUCE OR COPY IT
 III NOT TO REVEAL OR PUBLISH IT IN WHOLE OR PART
 IV ALL RIGHTS RESERVED



Apple Inc.

SYNC_DATE=07/21/2015

LOWER ANTENNA AND COUPLER

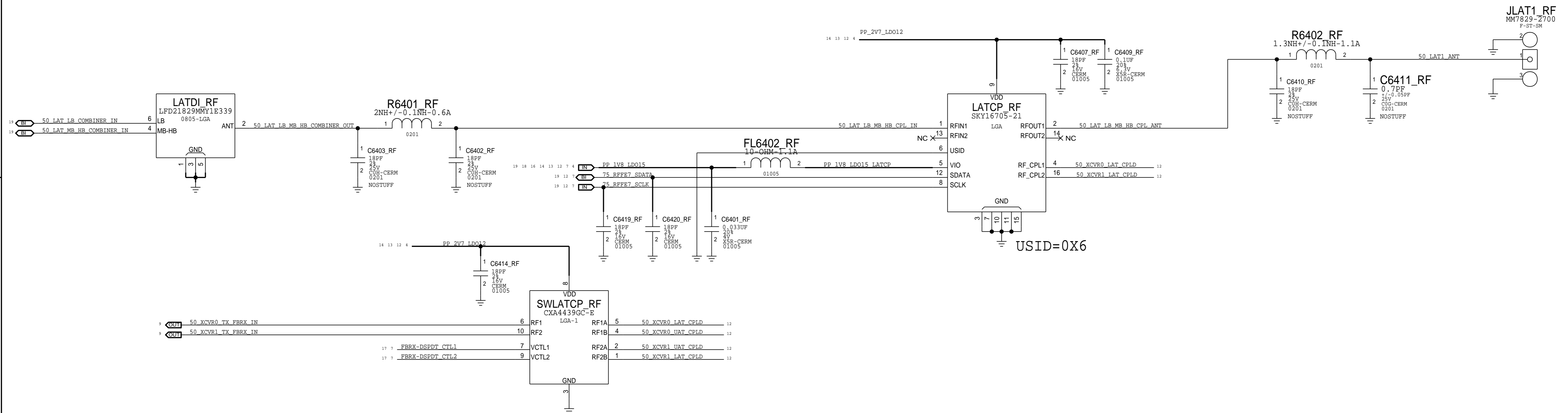

UPPER ANTENNA COUPLER

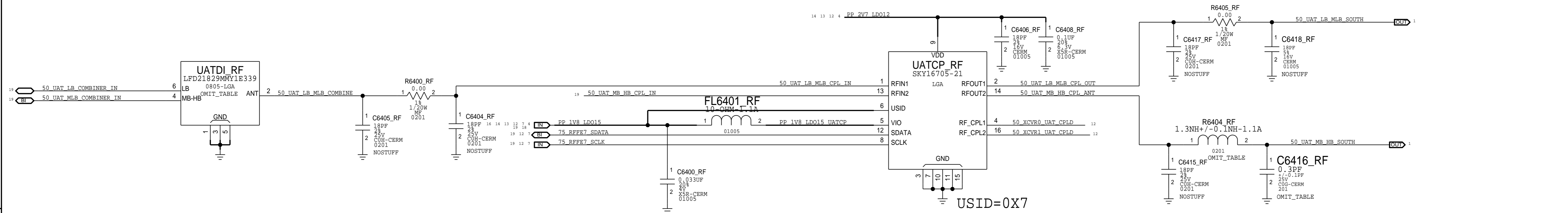

PAGE TITLE		DRAWING NUMBER		SIZE	
PAGE_TITLE=LOWER ANTENNA & COUPLERS		051-00482		D	
REVISION		8.0.0		BRANCH	
NOTICE OF PROPRIETARY PROPERTY:		PAGE		SHEET	
THE INFORMATION CONTAINED HEREIN IS THE PROPRIETARY PROPERTY OF APPLE INC. THE POSSESSOR AGREES TO THE FOLLOWING: I TO MAINTAIN THIS DOCUMENT IN CONFIDENCE II NOT TO REPRODUCE OR COPY IT III NOT TO REVEAL OR PUBLISH IT IN WHOLE OR PART IV ALL RIGHTS RESERVED		64 OF 72		73 OF 81	



Apple Inc.

DIVERSITY RECEIVE

LB DRX ASM

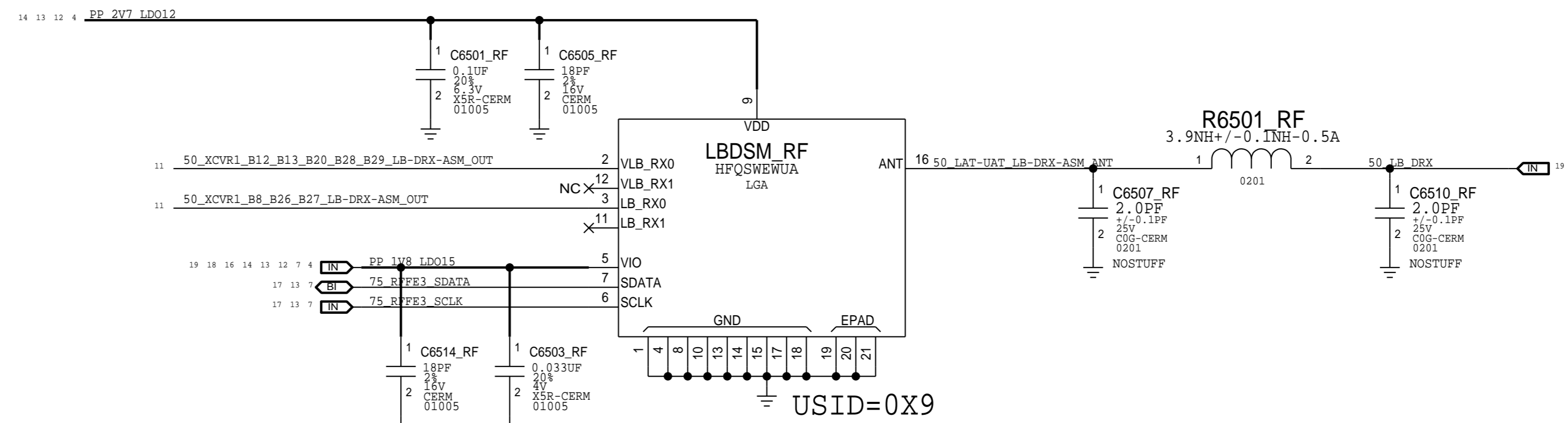

MB HB DRX ASM

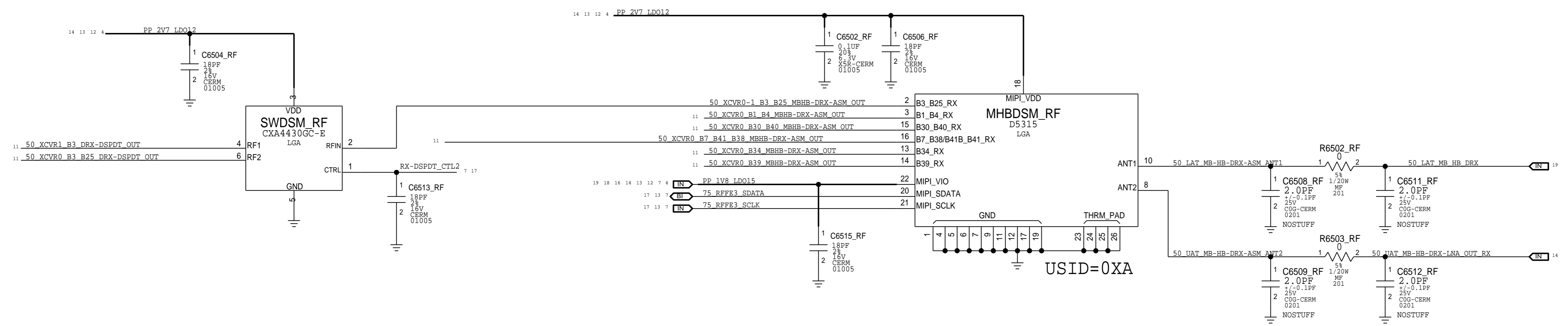

PAGE TITLE			SYNC_DATE=04/17/2015	
PAGE_TITLE=DIVERSITY RECEIVE ASM'S			DRAWING NUMBER	SIZE
			051-00482	D
			REVISION	8.0.0
NOTICE OF PROPRIETARY PROPERTY:			BRANCH	
THE INFORMATION CONTAINED HEREIN IS THE PROPRIETARY PROPERTY OF APPLE INC. THE POSSESSOR AGREES TO THE FOLLOWING: I TO MAINTAIN THIS DOCUMENT IN CONFIDENCE II NOT TO REPRODUCE OR COPY IT III NOT TO REVEAL OR PUBLISH IT IN WHOLE OR PART IV ALL RIGHTS RESERVED			PAGE	65 OF 72
			SHEET	74 OF 81

DIVERSITY RECEIVE LNAs

LB DRX LNA

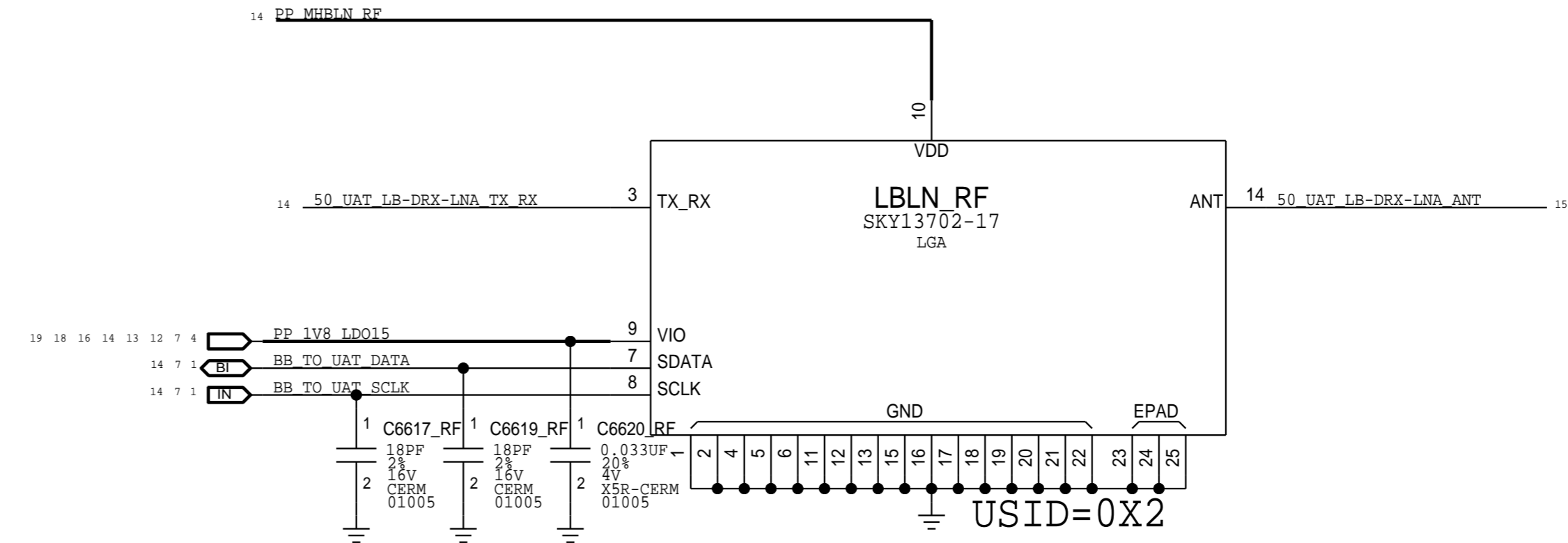

MB/HB DRX LNA

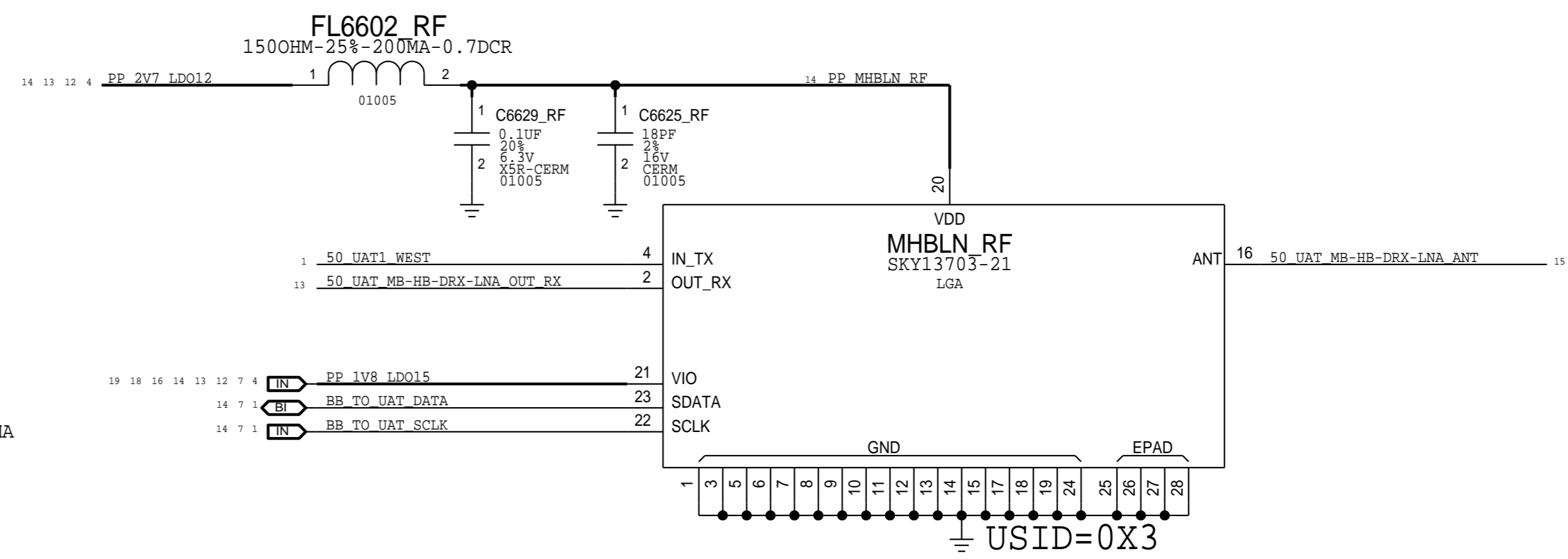

MLB DRX LNA

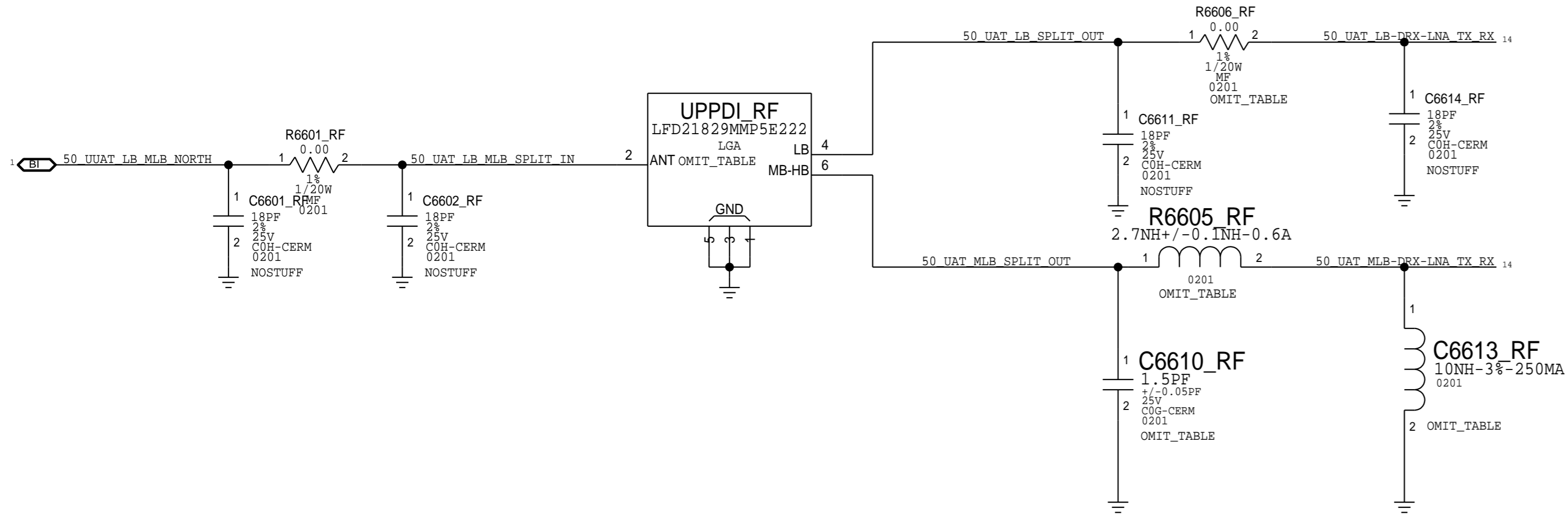
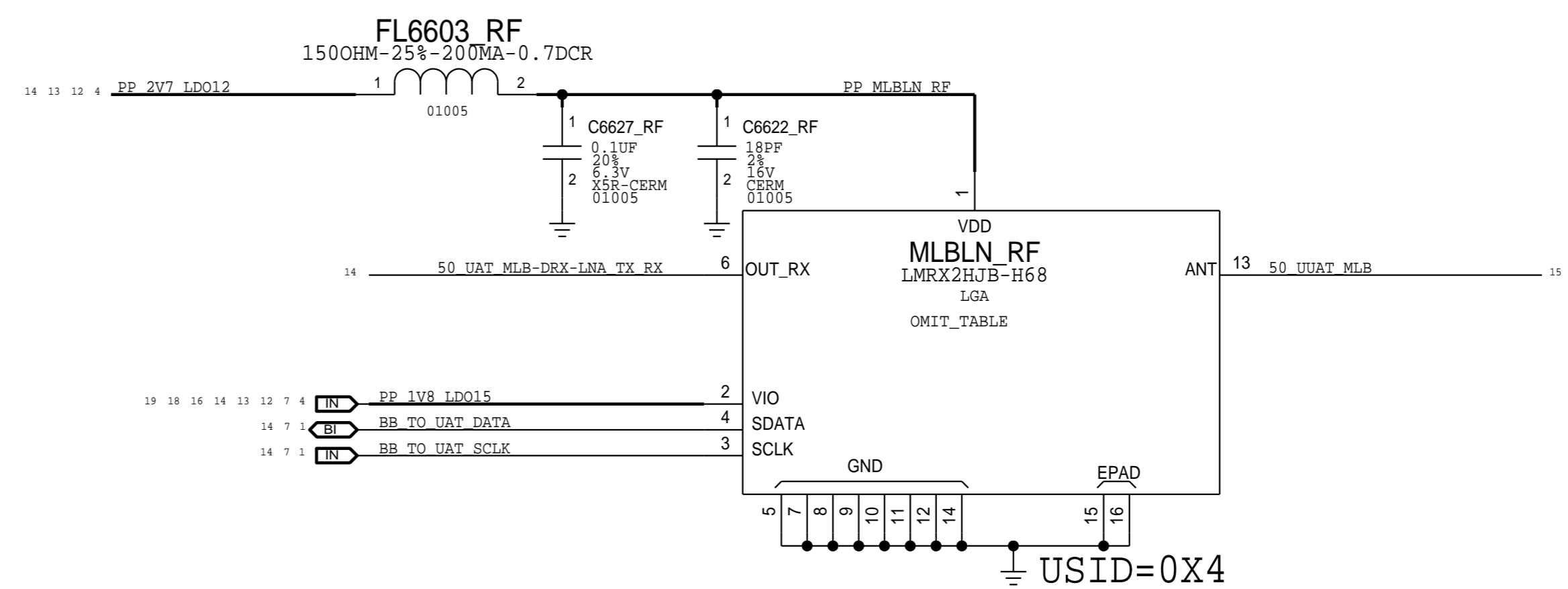

PAGE TITLE		DIVERSITY RECEIVE LNA'S	
DRAWING NUMBER		051-00482	SIZE D
REVISION		8.0.0	
BRANCH			
PAGE		66 OF 72	
SHEET		75 OF 81	

Apple Inc.
 NOTICE OF PROPRIETARY PROPERTY:
 THE INFORMATION CONTAINED HEREIN IS THE PROPRIETARY PROPERTY OF APPLE INC. THE POSSESSOR AGREES TO THE FOLLOWING:
 I TO MAINTAIN THIS DOCUMENT IN CONFIDENCE
 II NOT TO REPRODUCE OR COPY IT
 III NOT TO REVEAL OR PUBLISH IT IN WHOLE OR PART
 IV ALL RIGHTS RESERVED

UPPER ANTENNA FEEDS

UAT1

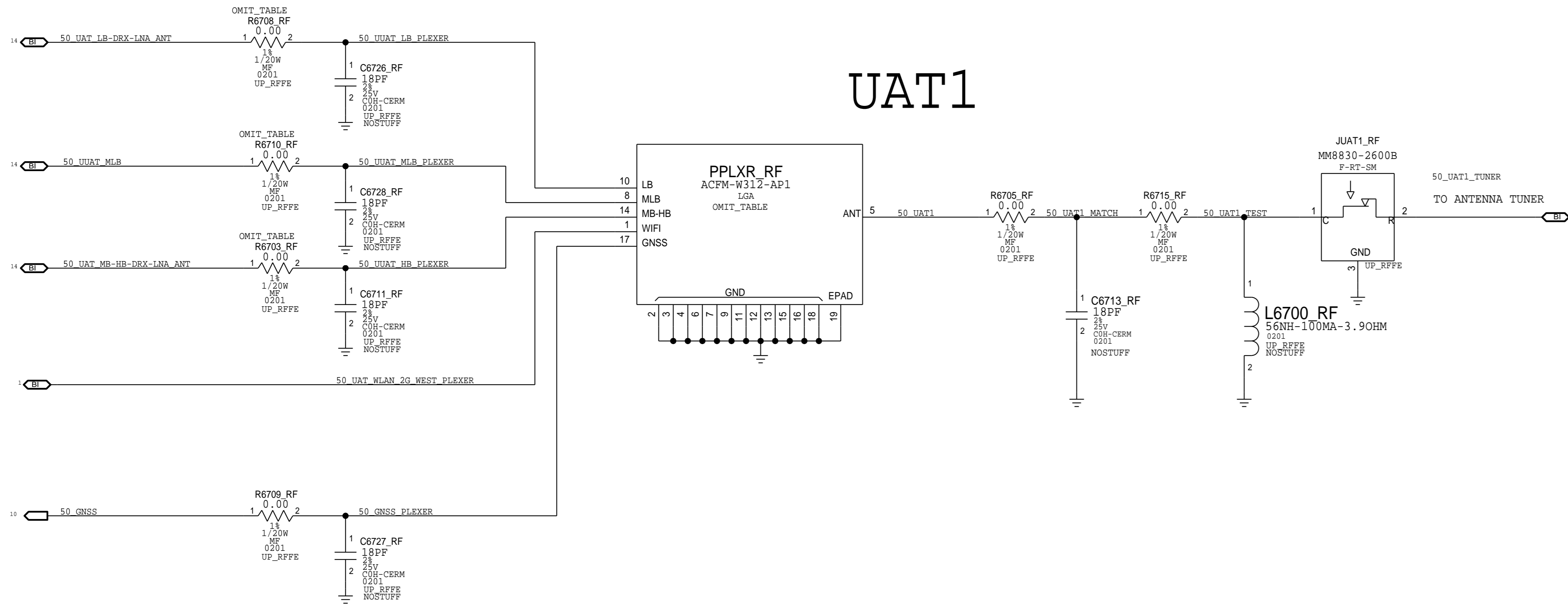

PAGE TITLE		SYNC_DATE=04/17/2015	
PAGE_TITLE=UPPER ANTENNA FEEDS			
Apple Inc.	DRAWING NUMBER	051-00482	SIZE D
	REVISION	8.0.0	
NOTICE OF PROPRIETARY PROPERTY: THE INFORMATION CONTAINED HEREIN IS THE PROPRIETARY PROPERTY OF APPLE INC. THE POSSESSOR AGREES TO THE FOLLOWING: I TO MAINTAIN THIS DOCUMENT IN CONFIDENCE II NOT TO REPRODUCE OR COPY IT III NOT TO REVEAL OR PUBLISH IT IN WHOLE OR PART IV ALL RIGHTS RESERVED		BRANCH	
		PAGE	67 OF 72
		SHEET	76 OF 81

PMU: ET MODULATOR

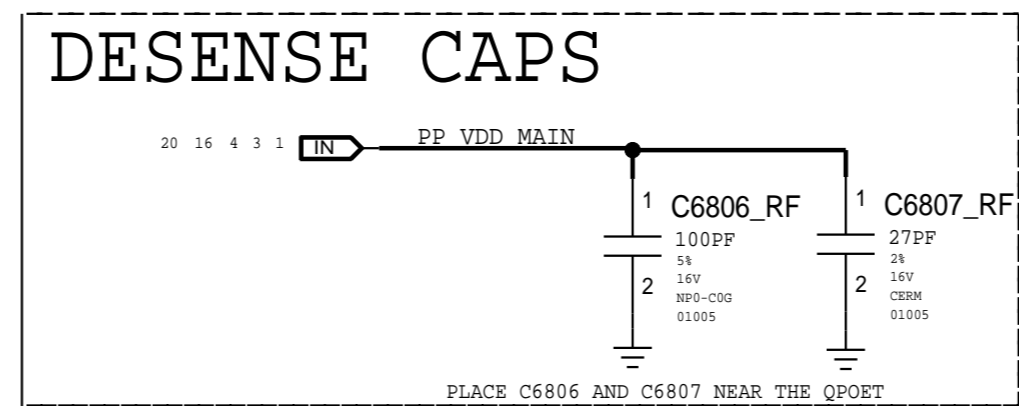
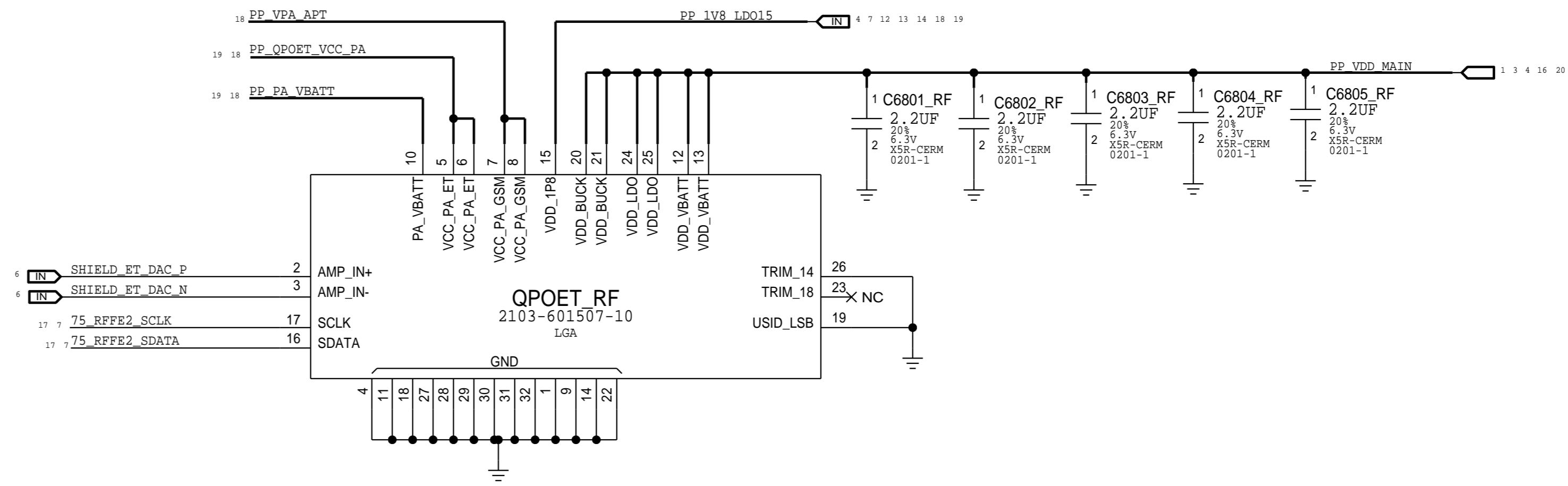

PAGE TITLE PMU: ET MODULATOR		
	DRAWING NUMBER 051-00482	SIZE D
	REVISION 8.0.0	BRANCH
NOTICE OF PROPRIETARY PROPERTY: THE INFORMATION CONTAINED HEREIN IS THE PROPRIETARY PROPERTY OF APPLE INC. THE POSSESSOR AGREES TO THE FOLLOWING: I TO MAINTAIN THIS DOCUMENT IN CONFIDENCE II NOT TO REPRODUCE OR COPY IT III NOT TO REVEAL OR PUBLISH IT IN WHOLE OR PART IV ALL RIGHTS RESERVED		
PAGE 68 OF 72	SHEET 77 OF 81	

MLB TEST POINTS

BASEBAND

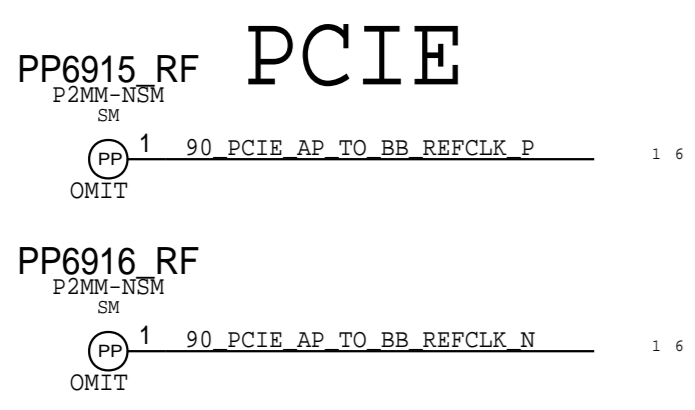
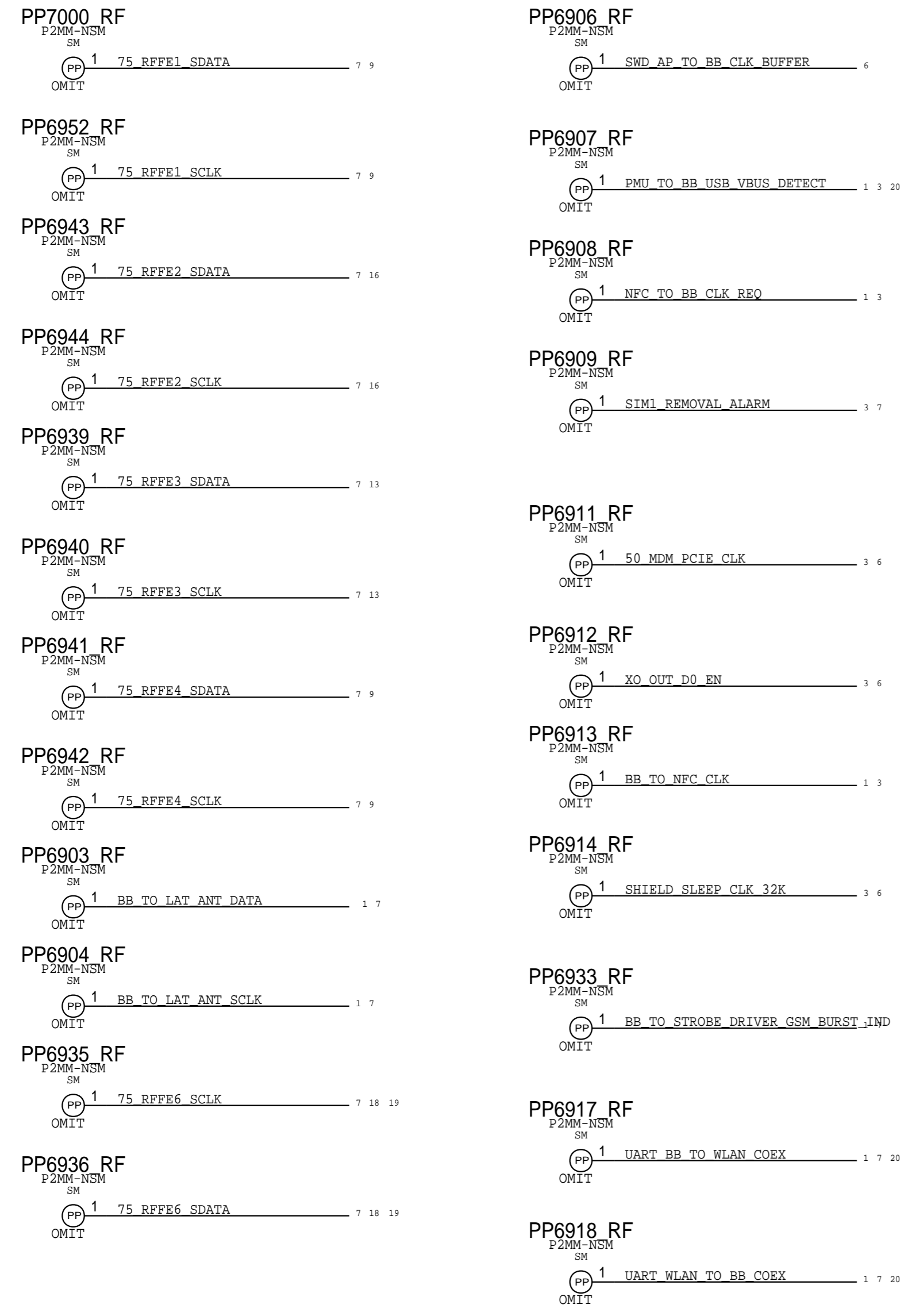

PCIE GND

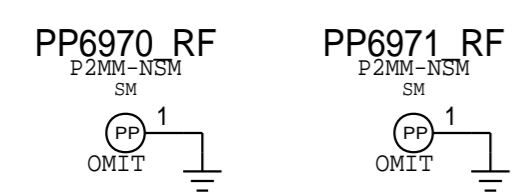

BBPMU

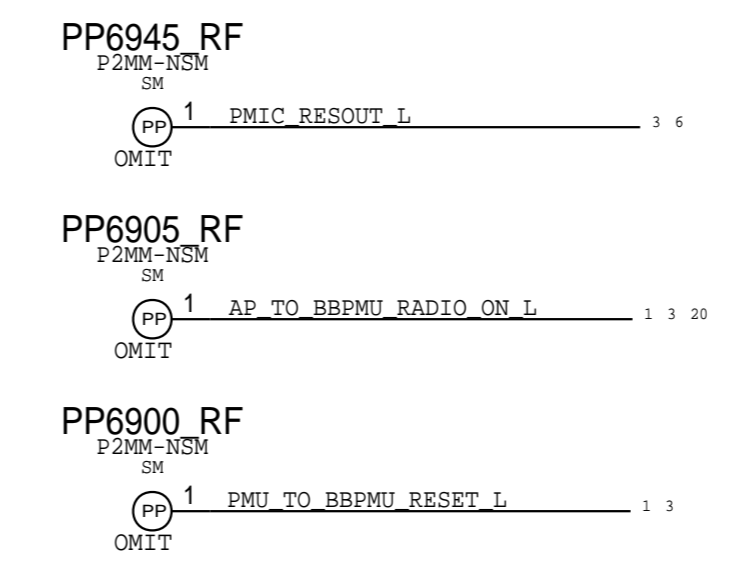

SIM



BOOT CONFIG

DEFAULT FAST_BOOT[2:0]
USB = 0X2

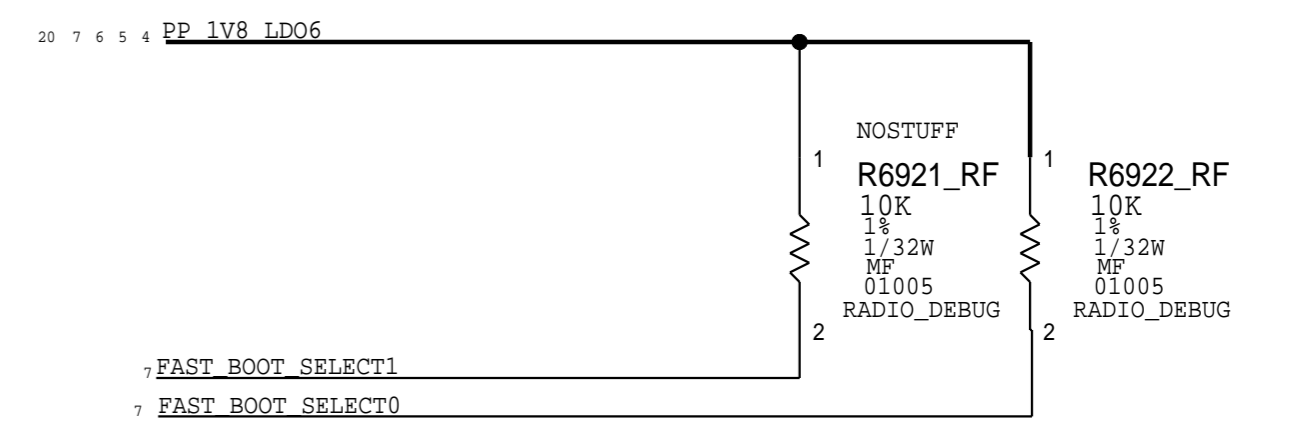

ICEFALL

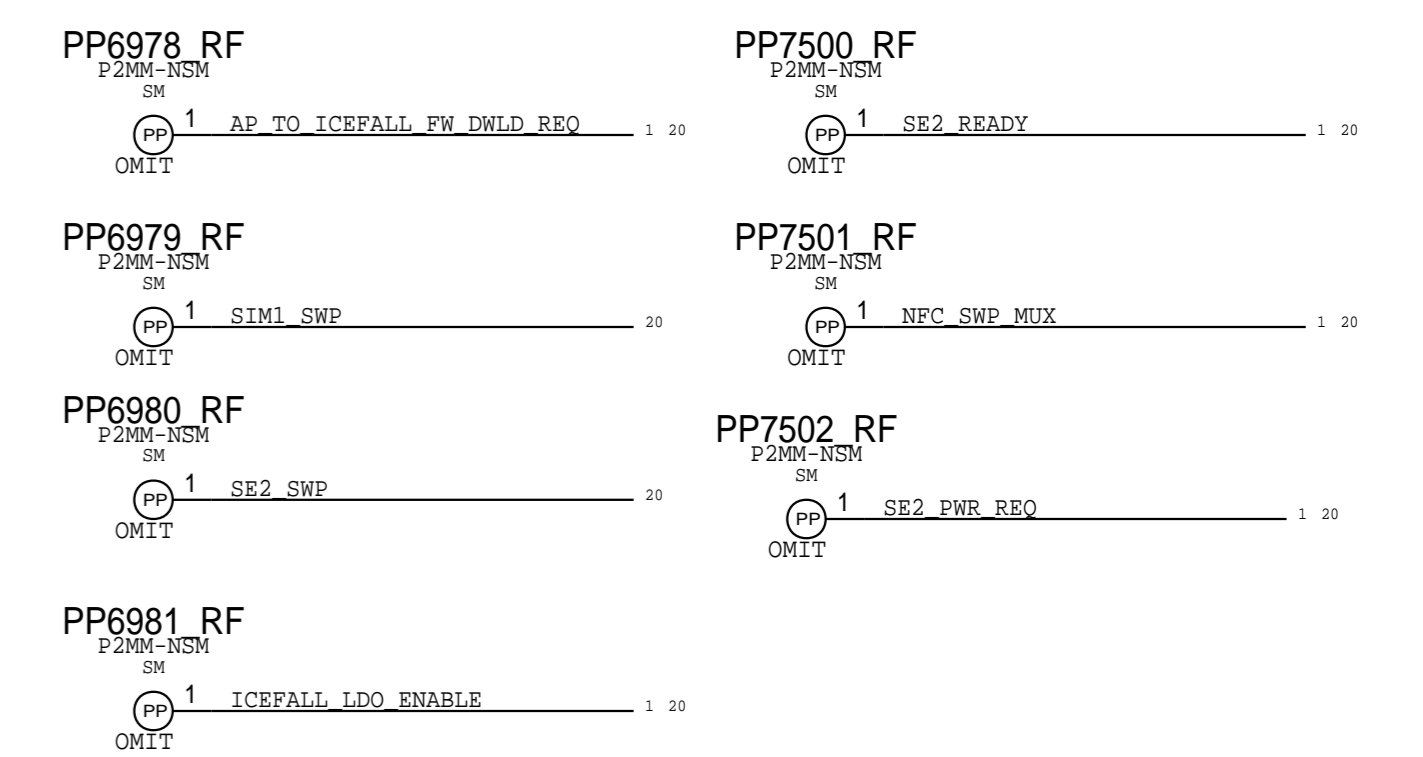

PAGE TITLE TEST POINTS & BOOT CONFIG		
	DRAWING NUMBER 051-00482	SIZE D
	REVISION 8.0.0	
NOTICE OF PROPRIETARY PROPERTY: THE INFORMATION CONTAINED HEREIN IS THE PROPRIETARY PROPERTY OF APPLE INC. THE POSSESSOR AGREES TO THE FOLLOWING: I TO MAINTAIN THIS DOCUMENT IN CONFIDENCE II NOT TO REPRODUCE OR COPY IT III NOT TO REVEAL OR PUBLISH IT IN WHOLE OR PART IV ALL RIGHTS RESERVED		
BRANCH	PAGE 69 OF 72	
SHEET 78 OF 81		

TDD TRANSMIT

2G PA

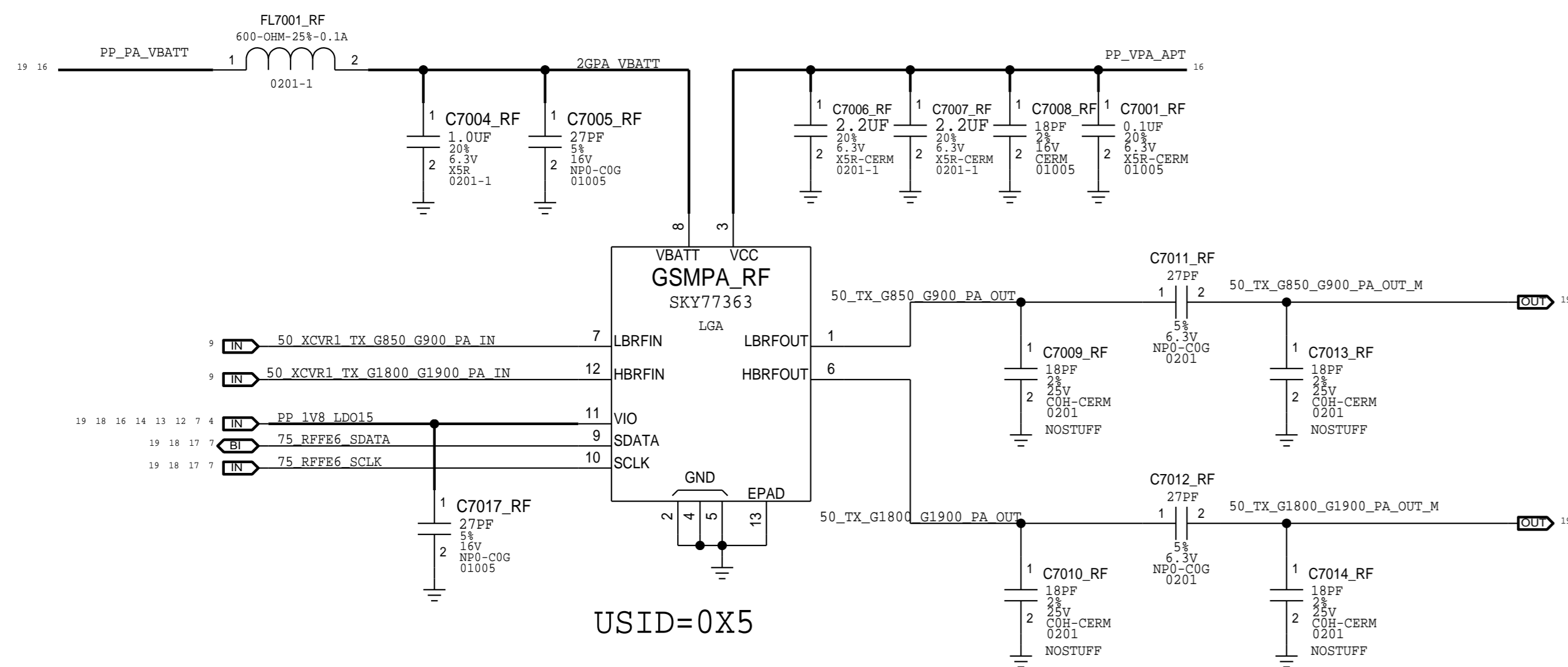

MB HB TDD PA

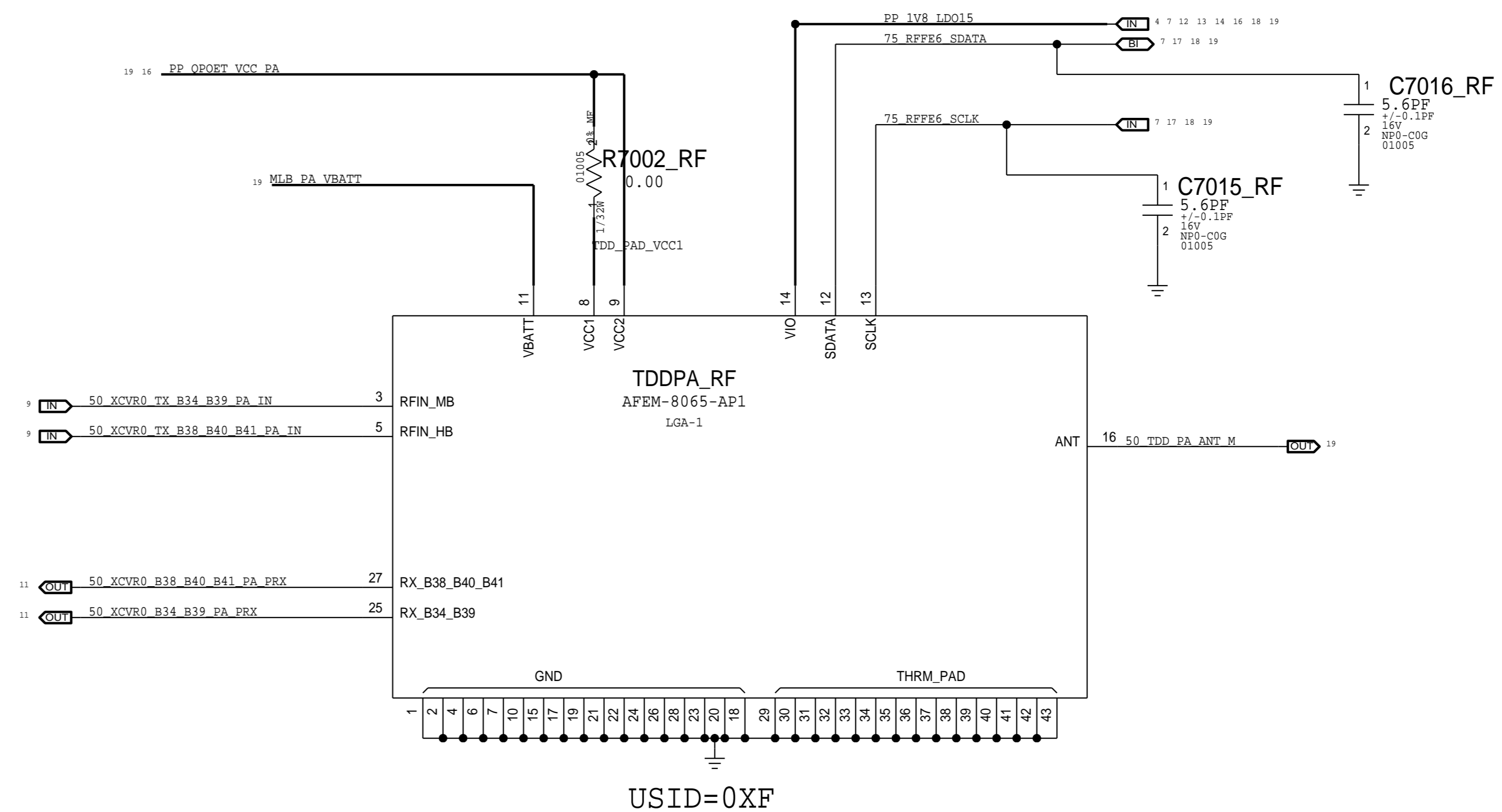

VIETMOBILE.VN

PAGE TITLE			PAGE_TITLE=TDD TRANSMIT		
DRAWING NUMBER		051-00482	REVISION		8.0.0
REVISION		8.0.0	BRANCH		
PAGE		70 OF 72	SHEET		79 OF 81
NOTICE OF PROPRIETARY PROPERTY: THE INFORMATION CONTAINED HEREIN IS THE PROPRIETARY PROPERTY OF APPLE INC. THE POSSESSOR AGREES TO THE FOLLOWING: I TO MAINTAIN THIS DOCUMENT IN CONFIDENCE II NOT TO REPRODUCE OR COPY IT III NOT TO REVEAL OR PUBLISH IT IN WHOLE OR PART IV ALL RIGHTS RESERVED					

FDD TRANSMIT

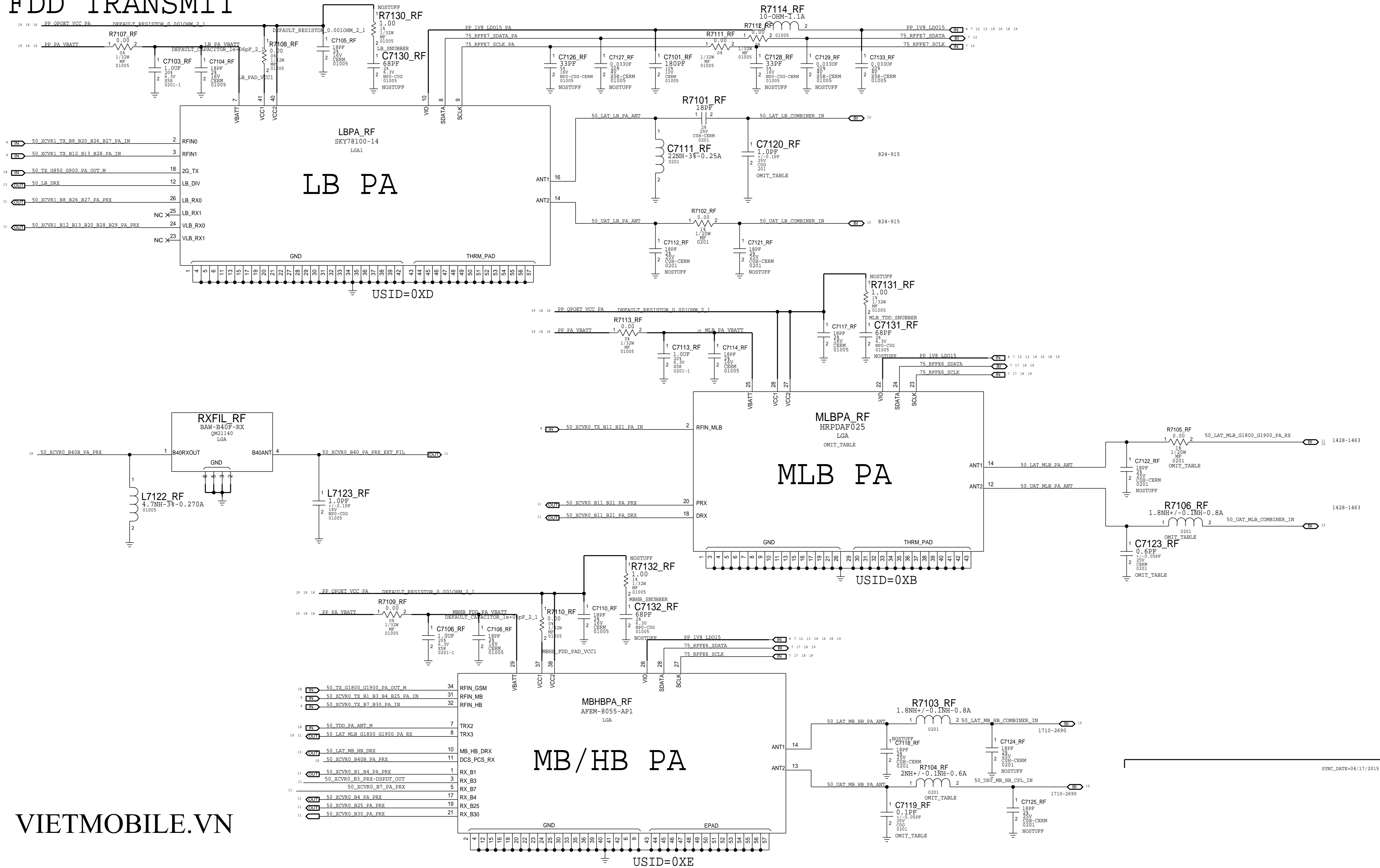

VIETMOBILE.VN

SYNC_DATE=04/17/2015

ICEFALL

SWP MUX

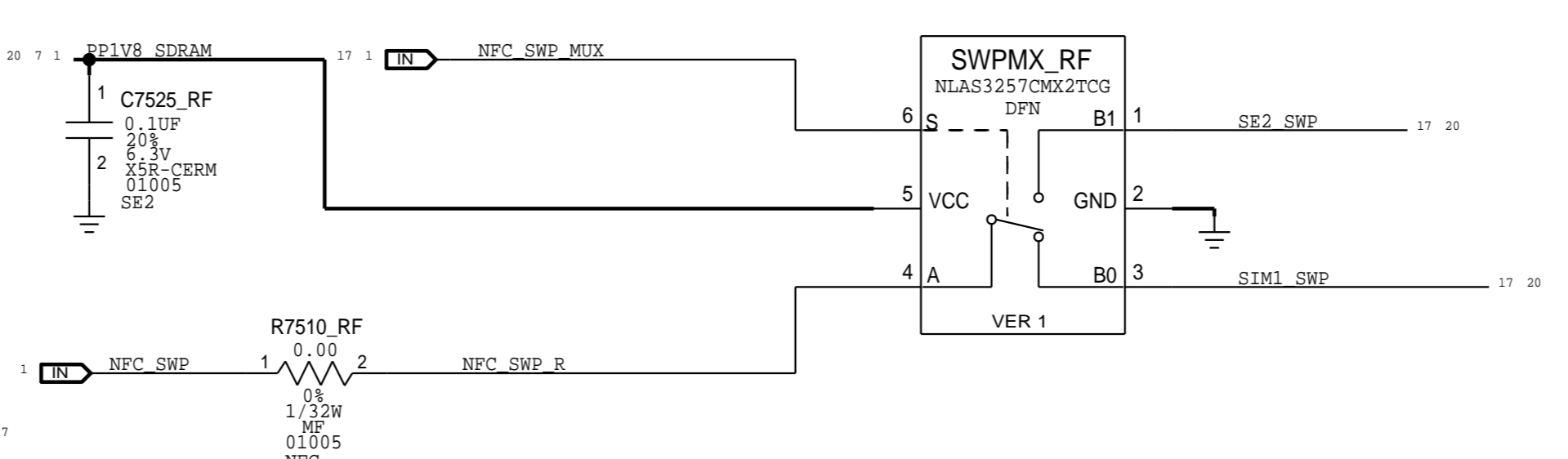
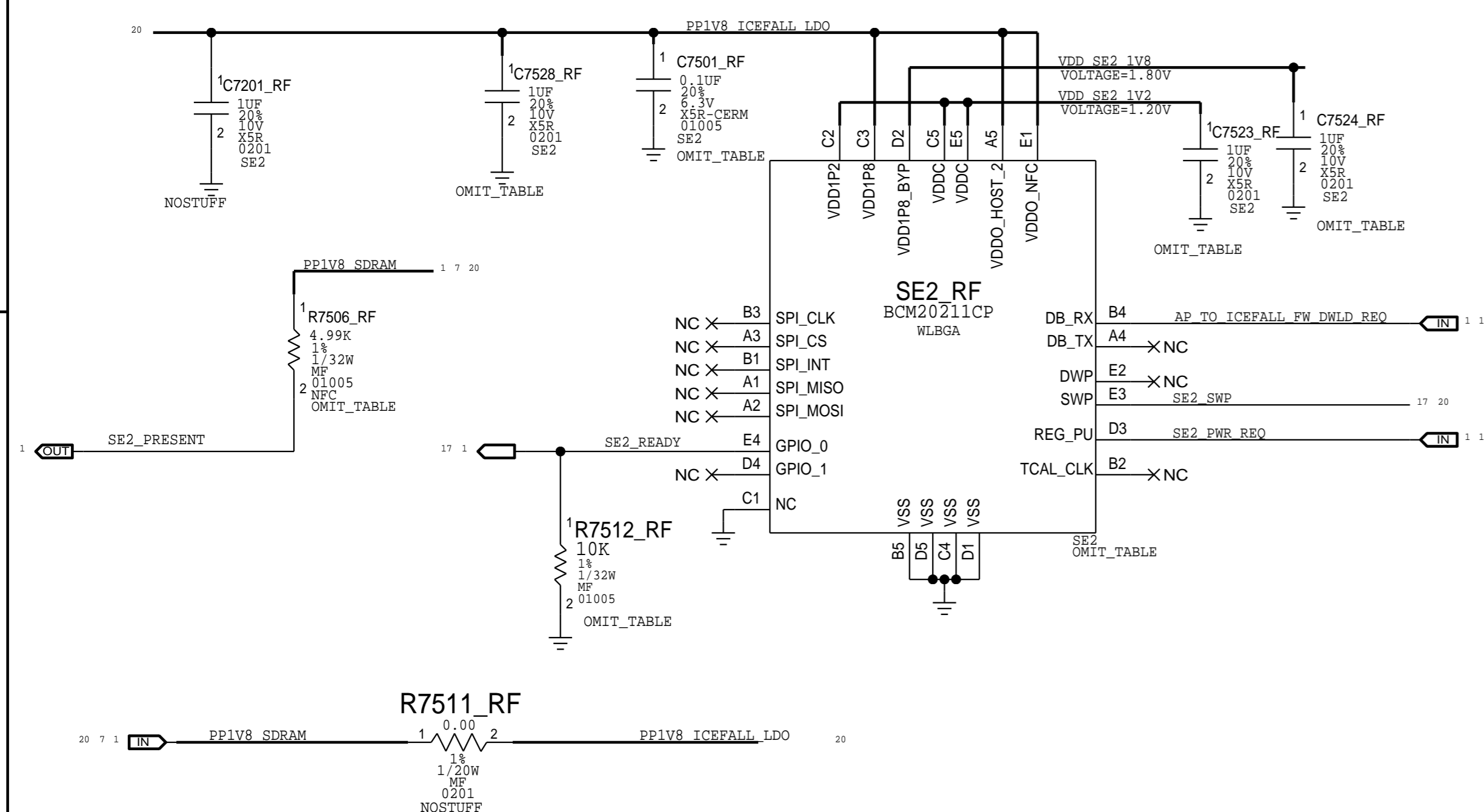

ICEFALL LDO

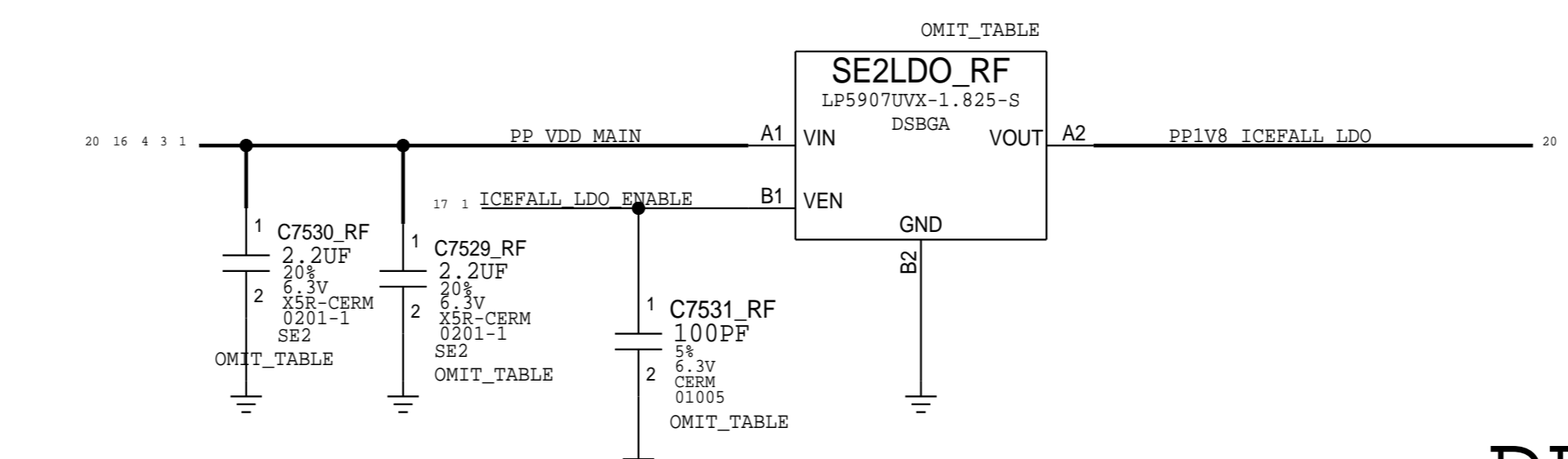

SIM CARD CONNECTOR

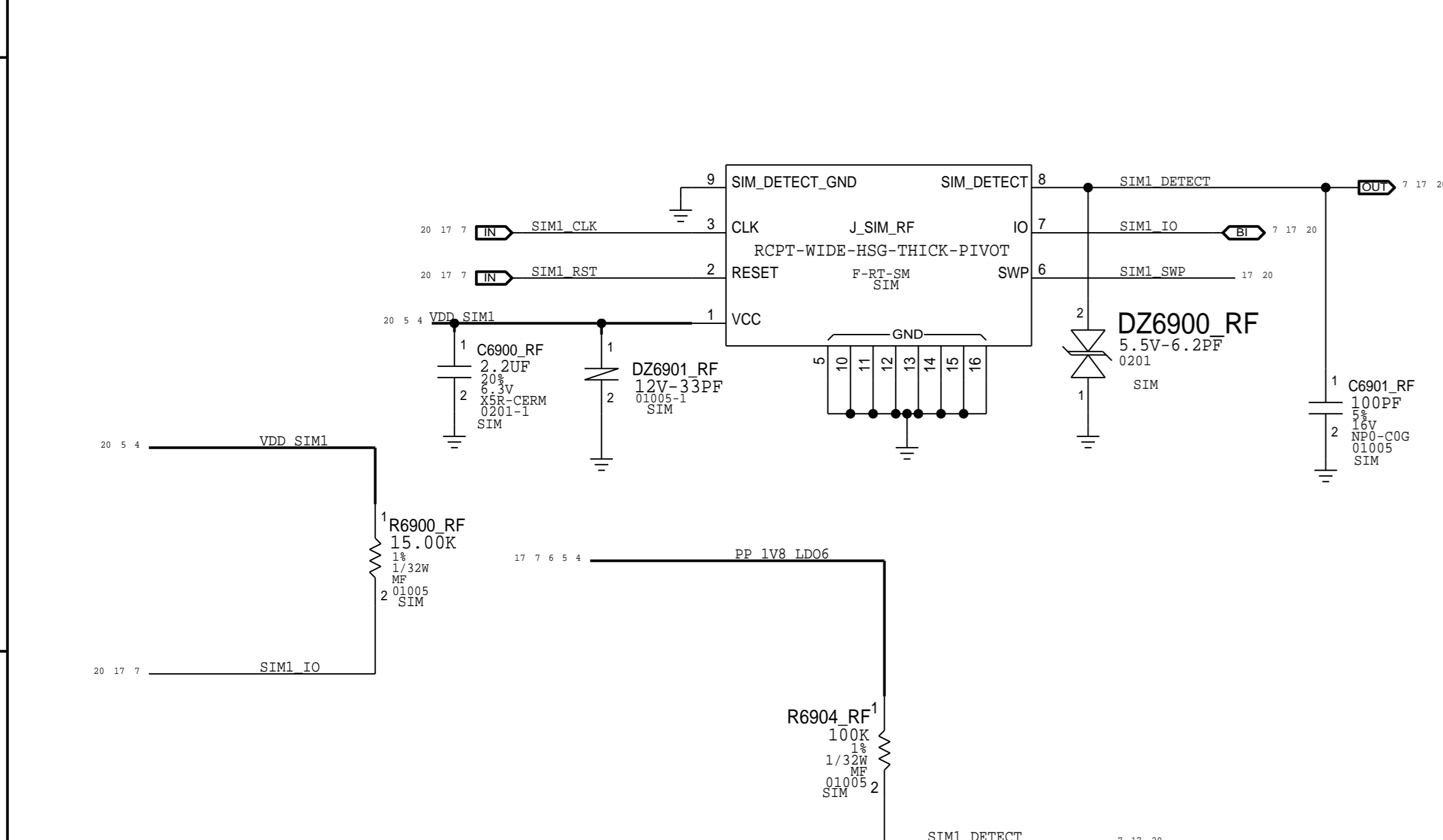

DEBUG CONNECTOR

