

Apple iPhone 11 Pro Schematic Diagram



Designed by Mobile1Tech.com

V1.0



www.Mobile1Tech.com

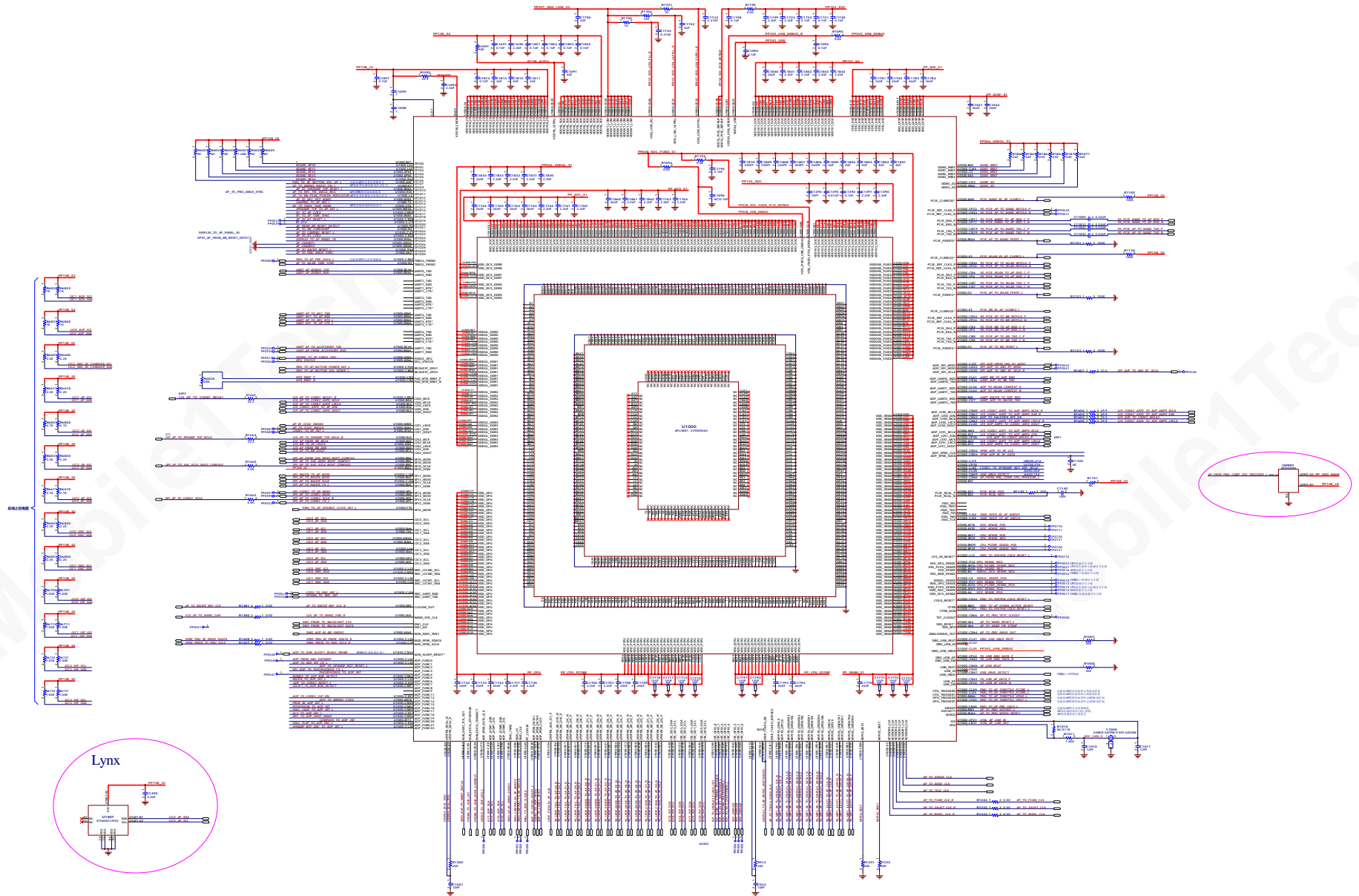

机械双SIM卡座 PSIM RCPT

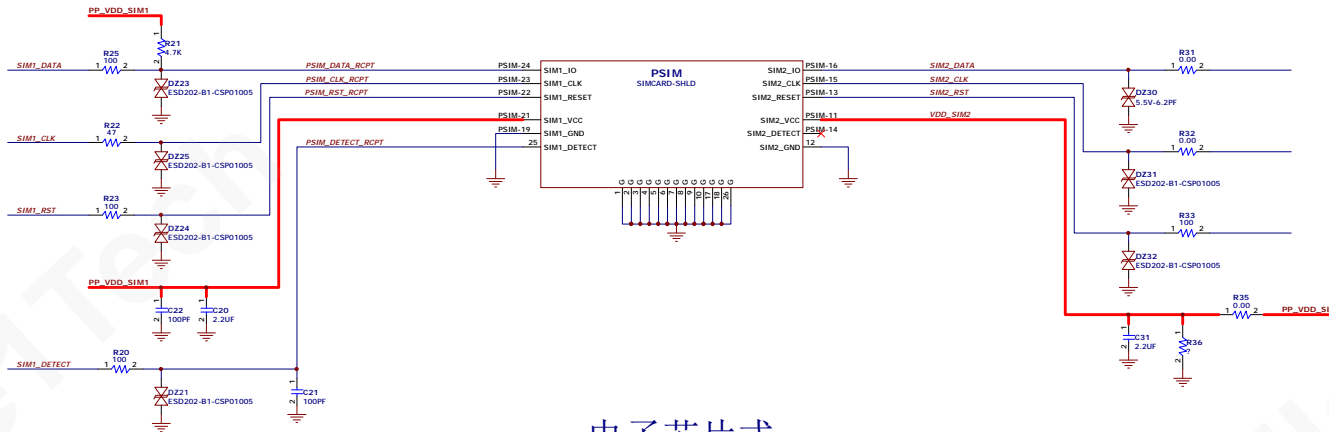

电子芯片式 USIM

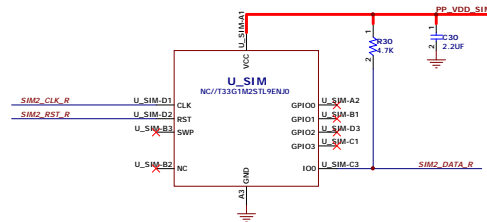

核心板与射频板连接器 (框) 上端

1	2	3	4	5	6	7	8																																																																																																																																																																																																																																																																																																																																																																																																																																																																																																																																																																																																																																																																																																																																																																																																																																																																																																																																																																																																																																																																																																																																																																																																																																																																																																																																																																																																																																																																																																																																																																																																															
<div style="display: flex; justify-content: space-between;"> <div style="width: 20%;"> <p>J_INT_TOP SMT-PAD SYM 1 of 3</p> <table border="1"> <tr><td>104</td><td>SO_LAA_TO_XCVR_LAT</td><td>GND</td><td>101</td></tr> <tr><td></td><td>GND</td><td>102</td><td>105</td></tr> <tr><td></td><td>GND</td><td>103</td><td>106</td></tr> <tr><td></td><td>GND</td><td>104</td><td>107</td></tr> <tr><td>111</td><td>SO_WLAN_A_RX1_LAA</td><td>J_INT_T0P2</td><td>108</td></tr> <tr><td></td><td>GND</td><td>109</td><td>111</td></tr> <tr><td></td><td>GND</td><td>110</td><td>112</td></tr> <tr><td>107</td><td>SO_WLAN_A_TX1</td><td>J_INT_T0P3</td><td>113</td></tr> <tr><td></td><td>GND</td><td>114</td><td>116</td></tr> <tr><td></td><td>GND</td><td>115</td><td>117</td></tr> <tr><td>124</td><td>VPA_ET_UHB</td><td>J_INT_T0P7</td><td>118</td></tr> <tr><td></td><td>GND</td><td>119</td><td>120</td></tr> <tr><td>122</td><td>VPA_ZG</td><td>J_INT_T0P13</td><td>121</td></tr> <tr><td></td><td>GND</td><td>122</td><td>123</td></tr> <tr><td>127</td><td>VPA_ET_UHB</td><td>J_INT_T0P14</td><td>124</td></tr> <tr><td></td><td>GND</td><td>125</td><td>126</td></tr> <tr><td>126</td><td>VPA_ZG</td><td>J_INT_T0P15</td><td>127</td></tr> <tr><td></td><td>GND</td><td>128</td><td>129</td></tr> <tr><td>131</td><td>VPA_ET_UHB</td><td>J_INT_T0P16</td><td>130</td></tr> <tr><td></td><td>GND</td><td>131</td><td>132</td></tr> <tr><td>130</td><td>VPA_ZG</td><td>J_INT_T0P17</td><td>133</td></tr> <tr><td></td><td>GND</td><td>134</td><td>135</td></tr> <tr><td>140</td><td>VPA_ET_UHB</td><td>J_INT_T0P23</td><td>136</td></tr> <tr><td></td><td>GND</td><td>137</td><td>138</td></tr> <tr><td></td><td>GND</td><td>139</td><td>140</td></tr> <tr><td>144</td><td>VPA_ET_UHB</td><td>J_INT_T0P24</td><td>141</td></tr> <tr><td></td><td>GND</td><td>142</td><td>143</td></tr> <tr><td>143</td><td>VPA_ZG</td><td>J_INT_T0P25</td><td>144</td></tr> <tr><td></td><td>GND</td><td>145</td><td>146</td></tr> <tr><td>157</td><td>VPA_ET_UHB</td><td>J_INT_T0P26</td><td>147</td></tr> <tr><td></td><td>GND</td><td>148</td><td>149</td></tr> <tr><td>153</td><td>VPA_ET_UHB</td><td>J_INT_T0P27</td><td>150</td></tr> <tr><td></td><td>GND</td><td>151</td><td>152</td></tr> <tr><td></td><td>GND</td><td>153</td><td>154</td></tr> <tr><td></td><td>GND</td><td>155</td><td>156</td></tr> <tr><td>169</td><td>GPIO_AP_CANARY1</td><td>J_INT_T0P30</td><td>157</td></tr> <tr><td></td><td>GND</td><td>158</td><td>159</td></tr> <tr><td></td><td>GND</td><td>160</td><td>161</td></tr> <tr><td></td><td>GND</td><td>162</td><td>163</td></tr> <tr><td></td><td>GND</td><td>164</td><td>165</td></tr> <tr><td></td><td>GND</td><td>166</td><td>167</td></tr> <tr><td></td><td>GND</td><td>168</td><td>169</td></tr> <tr><td></td><td>GND</td><td>170</td><td>171</td></tr> <tr><td></td><td>GND</td><td>172</td><td>173</td></tr> <tr><td></td><td>GND</td><td>174</td><td>175</td></tr> <tr><td></td><td>GND</td><td>176</td><td>177</td></tr> <tr><td></td><td>GND</td><td>178</td><td>179</td></tr> <tr><td></td><td>GND</td><td>180</td><td>181</td></tr> <tr><td></td><td>GND</td><td>182</td><td>183</td></tr> <tr><td></td><td>GND</td><td>184</td><td>185</td></tr> <tr><td></td><td>GND</td><td>186</td><td>187</td></tr> <tr><td></td><td>GND</td><td>188</td><td>189</td></tr> <tr><td></td><td>GND</td><td>190</td><td>191</td></tr> <tr><td></td><td>GND</td><td>192</td><td>193</td></tr> <tr><td></td><td>GND</td><td>194</td><td>195</td></tr> <tr><td></td><td>GND</td><td>196</td><td>197</td></tr> <tr><td></td><td>GND</td><td>198</td><td>199</td></tr> <tr><td></td><td>GND</td><td>200</td><td>201</td></tr> <tr><td></td><td>GND</td><td>202</td><td>203</td></tr> <tr><td></td><td>GND</td><td>204</td><td>205</td></tr> <tr><td></td><td>GND</td><td>206</td><td>207</td></tr> <tr><td></td><td>GND</td><td>208</td><td>209</td></tr> <tr><td></td><td>GND</td><td>210</td><td>211</td></tr> <tr><td></td><td>GND</td><td>212</td><td>213</td></tr> <tr><td></td><td>GND</td><td>214</td><td>215</td></tr> <tr><td></td><td>GND</td><td>216</td><td>217</td></tr> <tr><td></td><td>GND</td><td>218</td><td>219</td></tr> <tr><td></td><td>GND</td><td>220</td><td>221</td></tr> <tr><td></td><td>GND</td><td>222</td><td>223</td></tr> <tr><td></td><td>GND</td><td>224</td><td>225</td></tr> <tr><td></td><td>GND</td><td>226</td><td>227</td></tr> <tr><td></td><td>GND</td><td>228</td><td>229</td></tr> <tr><td></td><td>GND</td><td>230</td><td>231</td></tr> <tr><td></td><td>GND</td><td>232</td><td>233</td></tr> <tr><td></td><td>GND</td><td>234</td><td>235</td></tr> <tr><td></td><td>GND</td><td>236</td><td>237</td></tr> <tr><td></td><td>GND</td><td>238</td><td>239</td></tr> <tr><td></td><td>GND</td><td>240</td><td>241</td></tr> <tr><td></td><td>GND</td><td>242</td><td>243</td></tr> <tr><td></td><td>GND</td><td>244</td><td>245</td></tr> <tr><td></td><td>GND</td><td>246</td><td>247</td></tr> <tr><td></td><td>GND</td><td>248</td><td>249</td></tr> <tr><td></td><td>GND</td><td>250</td><td>251</td></tr> <tr><td></td><td>GND</td><td>252</td><td>253</td></tr> <tr><td></td><td>GND</td><td>254</td><td>255</td></tr> <tr><td></td><td>GND</td><td>256</td><td>257</td></tr> <tr><td></td><td>GND</td><td>258</td><td>259</td></tr> <tr><td></td><td>GND</td><td>260</td><td>261</td></tr> <tr><td></td><td>GND</td><td>262</td><td>263</td></tr> <tr><td></td><td>GND</td><td>264</td><td>265</td></tr> <tr><td></td><td>GND</td><td>266</td><td>267</td></tr> <tr><td></td><td>GND</td><td>268</td><td>269</td></tr> <tr><td></td><td>GND</td><td>270</td><td>271</td></tr> <tr><td></td><td>GND</td><td>272</td><td>273</td></tr> <tr><td></td><td>GND</td><td>274</td><td>275</td></tr> <tr><td></td><td>GND</td><td>276</td><td>277</td></tr> <tr><td></td><td>GND</td><td>278</td><td>279</td></tr> <tr><td></td><td>GND</td><td>280</td><td>281</td></tr> <tr><td></td><td>GND</td><td>282</td><td>283</td></tr> <tr><td></td><td>GND</td><td>284</td><td>285</td></tr> <tr><td></td><td>GND</td><td>286</td><td>287</td></tr> <tr><td></td><td>GND</td><td>288</td><td>289</td></tr> <tr><td></td><td>GND</td><td>290</td><td>291</td></tr> <tr><td></td><td>GND</td><td>292</td><td>293</td></tr> <tr><td></td><td>GND</td><td>294</td><td>295</td></tr> <tr><td></td><td>GND</td><td>296</td><td>297</td></tr> <tr><td></td><td>GND</td><td>298</td><td>299</td></tr> <tr><td></td><td>GND</td><td>300</td><td>301</td></tr> <tr><td></td><td>GND</td><td>302</td><td>303</td></tr> <tr><td></td><td>GND</td><td>304</td><td>305</td></tr> <tr><td></td><td>GND</td><td>306</td><td>307</td></tr> <tr><td></td><td>GND</td><td>308</td><td>309</td></tr> <tr><td></td><td>GND</td><td>310</td><td>311</td></tr> <tr><td></td><td>GND</td><td>312</td><td>313</td></tr> <tr><td></td><td>GND</td><td>314</td><td>315</td></tr> <tr><td></td><td>GND</td><td>316</td><td>317</td></tr> <tr><td></td><td>GND</td><td>318</td><td>319</td></tr> <tr><td></td><td>GND</td><td>320</td><td>321</td></tr> <tr><td></td><td>GND</td><td>322</td><td>323</td></tr> <tr><td></td><td>GND</td><td>324</td><td>325</td></tr> <tr><td></td><td>GND</td><td>326</td><td>327</td></tr> <tr><td></td><td>GND</td><td>328</td><td>329</td></tr> <tr><td></td><td>GND</td><td>330</td><td>331</td></tr> <tr><td></td><td>GND</td><td>332</td><td>333</td></tr> <tr><td></td><td>GND</td><td>334</td><td>335</td></tr> <tr><td></td><td>GND</td><td>336</td><td>337</td></tr> <tr><td></td><td>GND</td><td>338</td><td>339</td></tr> <tr><td></td><td>GND</td><td>340</td><td>341</td></tr> <tr><td></td><td>GND</td><td>342</td><td>343</td></tr> <tr><td></td><td>GND</td><td>344</td><td>345</td></tr> <tr><td></td><td>GND</td><td>346</td><td>347</td></tr> <tr><td></td><td>GND</td><td>348</td><td>349</td></tr> <tr><td></td><td>GND</td><td>350</td><td>351</td></tr> <tr><td></td><td>GND</td><td>352</td><td>353</td></tr> <tr><td></td><td>GND</td><td>354</td><td>355</td></tr> <tr><td></td><td>GND</td><td>356</td><td>357</td></tr> <tr><td></td><td>GND</td><td>358</td><td>359</td></tr> <tr><td></td><td>GND</td><td>360</td><td>361</td></tr> <tr><td></td><td>GND</td><td>362</td><td>363</td></tr> <tr><td></td><td>GND</td><td>364</td><td>365</td></tr> <tr><td></td><td>GND</td><td>366</td><td>367</td></tr> <tr><td></td><td>GND</td><td>368</td><td>369</td></tr> <tr><td></td><td>GND</td><td>370</td><td>371</td></tr> <tr><td></td><td>GND</td><td>372</td><td>373</td></tr> <tr><td></td><td>GND</td><td>374</td><td>375</td></tr> <tr><td></td><td>GND</td><td>376</td><td>377</td></tr> <tr><td></td><td>GND</td><td>378</td><td>379</td></tr> <tr><td></td><td>GND</td><td>380</td><td>381</td></tr> <tr><td></td><td>GND</td><td>382</td><td>383</td></tr> <tr><td></td><td>GND</td><td>384</td><td>385</td></tr> <tr><td></td><td>GND</td><td>386</td><td>387</td></tr> <tr><td></td><td>GND</td><td>388</td><td>389</td></tr> <tr><td></td><td>GND</td><td>390</td><td>391</td></tr> <tr><td></td><td>GND</td><td>392</td><td>393</td></tr> <tr><td></td><td>GND</td><td>394</td><td>395</td></tr> <tr><td></td><td>GND</td><td>396</td><td>397</td></tr> <tr><td></td><td>GND</td><td>398</td><td>399</td></tr> <tr><td></td><td>GND</td><td>400</td><td>401</td></tr> <tr><td></td><td>GND</td><td>402</td><td>403</td></tr> <tr><td></td><td>GND</td><td>404</td><td>405</td></tr> <tr><td></td><td>GND</td><td>406</td><td>407</td></tr> <tr><td></td><td>GND</td><td>408</td><td>409</td></tr> <tr><td></td><td>GND</td><td>410</td><td>411</td></tr> <tr><td></td><td>GND</td><td>412</td><td>413</td></tr> <tr><td></td><td>GND</td><td>414</td><td>415</td></tr> <tr><td></td><td>GND</td><td>416</td><td>417</td></tr> <tr><td></td><td>GND</td><td>418</td><td>419</td></tr> <tr><td></td><td>GND</td><td>420</td><td>421</td></tr> <tr><td></td><td>GND</td><td>422</td><td>423</td></tr> <tr><td></td><td>GND</td><td>424</td><td>425</td></tr> <tr><td></td><td>GND</td><td>426</td><td>427</td></tr> <tr><td></td><td>GND</td><td>428</td><td>429</td></tr> <tr><td></td><td>GND</td><td>430</td><td>431</td></tr> <tr><td></td><td>GND</td><td>432</td><td>433</td></tr> <tr><td></td><td>GND</td><td>434</td><td>435</td></tr> <tr><td></td><td>GND</td><td>436</td><td>437</td></tr> <tr><td></td><td>GND</td><td>438</td><td>439</td></tr> <tr><td></td><td>GND</td><td>440</td><td>441</td></tr> <tr><td></td><td>GND</td><td>442</td><td>443</td></tr> <tr><td></td><td>GND</td><td>444</td><td>445</td></tr> <tr><td></td><td>GND</td><td>446</td><td>447</td></tr> <tr><td></td><td>GND</td><td>448</td><td>449</td></tr> <tr><td></td><td>GND</td><td>450</td><td>451</td></tr> <tr><td></td><td>GND</td><td>452</td><td>453</td></tr> <tr><td></td><td>GND</td><td>454</td><td>455</td></tr> <tr><td></td><td>GND</td><td>456</td><td>457</td></tr> <tr><td></td><td>GND</td><td>458</td><td>459</td></tr> <tr><td></td><td>GND</td><td>460</td><td>461</td></tr> <tr><td></td><td>GND</td><td>462</td><td>463</td></tr> <tr><td></td><td>GND</td><td>464</td><td>465</td></tr> <tr><td></td><td>GND</td><td>466</td><td>467</td></tr> <tr><td></td><td>GND</td><td>468</td><td>469</td></tr> <tr><td></td><td>GND</td><td>470</td><td>471</td></tr> <tr><td></td><td>GND</td><td>472</td><td>473</td></tr> <tr><td></td><td>GND</td><td>474</td><td>475</td></tr> <tr><td></td><td>GND</td><td>476</td><td>477</td></tr> <tr><td></td><td>GND</td><td>478</td><td>479</td></tr> <tr><td></td><td>GND</td><td>480</td><td>481</td></tr> <tr><td></td><td>GND</td><td>482</td><td>483</td></tr> <tr><td></td><td>GND</td><td>484</td><td>485</td></tr> <tr><td></td><td>GND</td><td>486</td><td>487</td></tr> <tr><td></td><td>GND</td><td>488</td><td>489</td></tr> <tr><td></td><td>GND</td><td>490</td><td>491</td></tr> <tr><td></td><td>GND</td><td>492</td><td>493</td></tr> <tr><td></td><td>GND</td><td>494</td><td>495</td></tr> <tr><td></td><td>GND</td><td>496</td><td>497</td></tr> <tr><td></td><td>GND</td><td>498</td><td>499</td></tr> <tr><td></td><td>GND</td><td>500</td><td>501</td></tr> <tr><td></td><td>GND</td><td>502</td><td>503</td></tr> <tr><td></td><td>GND</td><td>504</td><td>505</td></tr> <tr><td></td><td>GND</td><td>506</td><td>507</td></tr> <tr><td></td><td>GND</td><td>508</td><td>509</td></tr> <tr><td></td><td>GND</td><td>510</td><td>511</td></tr> <tr><td></td><td>GND</td><td>512</td><td>513</td></tr> <tr><td></td><td>GND</td><td>514</td><td>515</td></tr> <tr><td></td><td>GND</td><td>516</td><td>517</td></tr> <tr><td></td><td>GND</td><td>518</td><td>519</td></tr> <tr><td></td><td>GND</td><td>520</td><td>521</td></tr> <tr><td></td><td>GND</td><td>522</td><td>523</td></tr> <tr><td></td><td>GND</td><td>524</td><td>525</td></tr> <tr><td></td><td>GND</td><td>526</td><td>527</td></tr> <tr><td></td><td>GND</td><td>528</td><td>529</td></tr> <tr><td></td><td>GND</td><td>530</td><td>531</td></tr> <tr><td></td><td>GND</td><td>532</td><td>533</td></tr> <tr><td></td><td>GND</td><td>534</td><td>535</td></tr> <tr><td></td><td>GND</td><td>536</td><td>537</td></tr> <tr><td></td><td>GND</td><td>538</td><td>539</td></tr> <tr><td></td><td>GND</td><td>540</td><td>541</td></tr> <tr><td></td><td>GND</td><td>542</td><td>543</td></tr> <tr><td></td><td>GND</td><td>544</td><td>545</td></tr> <tr><td></td><td>GND</td><td>546</td><td>547</td></tr> <tr><td></td><td>GND</td><td>548</td><td>549</td></tr> <tr><td></td><td>GND</td><td>550</td><td>551</td></tr> <tr><td></td><td>GND</td><td>552</td><td>553</td></tr> <tr><td></td><td>GND</td><td>554</td><td>555</td></tr> <tr><td></td><td>GND</td><td>556</td><td>557</td></tr> <tr><td></td><td>GND</td><td>558</td><td>559</td></tr> <tr><td></td><td>GND</td><td>560</td><td>561</td></tr> <tr><td></td><td>GND</td><td>562</td><td>563</td></tr> <tr><td></td><td>GND</td><td>564</td><td>565</td></tr> <tr><td></td><td>GND</td><td>566</td><td>567</td></tr> <tr><td></td><td>GND</td><td>568</td><td>569</td></tr> <tr><td></td><td>GND</td><td>570</td><td>571</td></tr> <tr><td></td><td>GND</td><td>572</td><td>573</td></tr> <tr><td></td><td>GND</td><td>574</td><td>575</td></tr> <tr><td></td><td>GND</td><td>576</td><td>577</td></tr> <tr><td></td><td>GND</td><td>578</td><td>579</td></tr> <tr><td></td><td>GND</td><td>580</td><td>581</td></tr> <tr><td></td><td>GND</td><td>582</td><td>583</td></tr> <tr><td></td><td>GND</td><td>584</td><td>585</td></tr> <tr><td></td><td>GND</td><td>586</td><td>587</td></tr> <tr><td></td><td>GND</td><td>588</td><td>589</td></tr> <tr><td></td><td>GND</td><td>590</td><td>591</td></tr> <tr><td></td><td>GND</td><td>592</td><td>593</td></tr> <tr><td></td><td>GND</td><td>594</td><td>595</td></tr> <tr><td></td><td>GND</td><td>596</td><td>597</td></tr> <tr><td></td><td>GND</td><td>598</td><td>599</td></tr> <tr><td></td><td>GND</td><td>600</td><td>601</td></tr> <tr><td></td><td>GND</td><td>602</td><td>603</td></tr> <tr><td></td><td>GND</td><td>604</td><td>605</td></tr> <tr><td></td><td>GND</td><td>606</td><td>607</td></tr> <tr><td></td><td>GND</td><td>608</td><td>609</td></tr> <tr><td></td><td>GND</td><td>610</td><td>611</td></tr> <tr><td></td><td>GND</td><td>612</td><td>613</td></tr> <tr><td></td><td>GND</td><td>614</td><td>615</td></tr> <tr><td></td><td>GND</td><td>616</td><td>617</td></tr> <tr><td></td><td>GND</td><td>618</td><td>619</td></tr> <tr><td></td><td>GND</td><td>620</td><td>621</td></tr> <tr><td></td><td>GND</td><td>622</td><td>623</td></tr> <tr><td></td><td>GND</td><td>624</td><td>625</td></tr> <tr><td></td><td>GND</td><td>626</td><td>627</td></tr> <tr><td></td><td>GND</td><td>628</td><td>629</td></tr> <tr><td></td><td>GND</td><td>630</td><td>631</td></tr> <tr><td></td><td>GND</td><td>632</td><td>633</td></tr> <tr><td></td><td>GND</td><td>634</td><td>635</td></tr> <tr><td></td><td>GND</td><td>636</td><td>637</td></tr> <tr><td></td><td>GND</td><td>638</td><td>639</td></tr> <tr><td></td><td>GND</td><td>640</td><td>641</td></tr> <tr><td></td><td>GND</td><td>642</td><td>643</td></tr> <tr><td></td><td>GND</td><td>644</td><td>645</td></tr> <tr><td></td><td>GND</td><td>646</td><td>647</td></tr> <tr><td></td><td>GND</td><td>648</td><td>649</td></tr> <tr><td></td><td>GND</td><td>650</td><td>651</td></tr> <tr><td></td><td>GND</td><td>652</td><td>653</td></tr> <tr><td></td><td>GND</td><td>654</td><td>655</td></tr> <tr><td></td><td>GND</td><td>656</td><td>657</td></tr> <tr><td></td><td>GND</td><td>658</td><td>659</td></tr> <tr><td></td><td>GND</td><td>660</td><td>661</td></tr> <tr><td></td><td>GND</td><td>662</td><td>663</td></tr> <tr><td></td><td>GND</td><td>664</td><td>665</td></tr> <tr><td></td><td>GND</td><td>666</td><td>667</td></tr> <tr><td></td><td>GND</td><td>668</td><td>669</td></tr> <tr><td></td><td>GND</td><td>670</td><td>671</td></tr> <tr><td></td><td>GND</td><td>672</td><td>673</td></tr> <tr><td></td><td>GND</td><td>674</td><td>675</td></tr> <tr><td></td><td>GND</td><td>676</td><td>677</td></tr> <tr><td></td><td>GND</td><td>678</td><td>679</td></tr> <tr><td></td><td>GND</td><td>680</td><td>681</td></tr> <tr><td></td><td>GND</td><td>682</td><td>683</td></tr> <tr><td></td><td>GND</td><td>684</td><td>685</td></tr> <tr><td></td><td>GND</td><td>686</td><td>687</td></tr> <tr><td></td><td>GND</td><td>688</td><td>689</td></tr> <tr><td></td><td>GND</td><td>690</td><td>691</td></tr> <tr><td></td><td>GND</td><td>692</td><td>693</td></tr> <tr><td></td><td>GND</td><td>694</td><td>695</td></tr> <tr><td></td><td>GND</td><td>696</td><td>697</td></tr> <tr><td></td><td>GND</td><td>698</td><td>699</td></tr> <tr><td></td><td>GND</td><td>700</td><td>701</td></tr> <tr><td></td><td>GND</td><td>702</td><td>703</td></tr> <tr><td></td><td>GND</td><td>704</td><td>705</td></tr> <tr><td></td><td>GND</td><td>706</td><td>707</td></tr> <tr><td></td><td>GND</td><td>708</td><td>709</td></tr> <tr><td></td><td>GND</td><td>710</td><td>711</td></tr> <tr><td></td><td>GND</td><td>712</td><td>713</td></tr> <tr><td></td><td>GND</td><td>714</td><td>715</td></tr> <tr><td></td><td>GND</td><td>716</td><td>717</td></tr> <tr><td></td><td>GND</td><td>718</td><td>719</td></tr> <tr><td></td><td>GND</td><td>720</td><td>721</td></tr> <tr><td></td><td>GND</td><td>722</td><td>723</td></tr> <tr><td></td><td>GND</td><td>724</td><td>725</td></tr> <tr><td></td><td>GND</td><td>726</td><td>727</td></tr> <tr><td></td><td>GND</td><td>728</td><td>729</td></tr> <tr><td></td><td>GND</td><td>730</td><td>731</td></tr> <tr><td></td><td>GND</td><td>732</td><td>733</td></tr> <tr><td></td><td>GND</td><td>734</td><td>735</td></tr> <tr><td></td><td>GND</td><td>736</td><td>737</td></tr> <tr><td></td><td>GND</td><td>738</td><td>739</td></tr> <tr><td></td><td>GND</td><td>740</td><td>741</td></tr> <tr><td></td><td>GND</td><td>742</td><td>743</td></tr> <tr><td></td><td>GND</td><td>744</td><td>745</td></tr> <tr><td></td><td>GND</td><td>746</td><td>747</td></tr> <tr><td></td><td>GND</td><td>748</td><td>749</td></tr> <tr><td></td><td>GND</td><td>750</td><td>751</td></tr> <tr><td></td><td>GND</td><td>752</td><td>753</td></tr> <tr><td></td><td>GND</td><td>754</td><td>755</td></tr> <tr><td></td><td>GND</td><td>756</td><td>757</td></tr> <tr><td></td><td>GND</td><td>758</td><td>759</td></tr> <tr><td></td><td>GND</td><td>760</td><td>761</td></tr> <tr><td></td><td>GND</td><td>762</td><td>763</td></tr> <tr><td></td><td>GND</td><td>764</td><td>765</td></tr> <tr><td></td><td>GND</td><td>766</td><td>767</td></tr> <tr><td></td><td>GND</td><td>768</td><td>769</td></tr> <tr><td></td><td>GND</td><td>770</td><td>771</td></tr> <tr><td></td><td>GND</td><td>772</td><td>773</td></tr> <tr><td></td><td>GND</td><td>774</td><td>775</td></tr> <tr><td></td><td>GND</td><td>776</td><td>777</td></tr> <tr><td></td><td>GND</td><td>778</td><td>779</td></tr> <tr><td></td><td>GND</td><td>780</td><td>781</td></tr> <tr><td></td><td>GND</td><td>782</td><td>783</td></tr> <tr><td></td><td>GND</td><td>784</td><td>785</td></tr> <tr><td></td><td>GND</td><td>786</td><td>787</td></tr> <tr><td></td><td>GND</td><td>788</td><td>789</td></tr> <tr><td></td><td>GND</td><td>790</td><td>791</td></tr> <tr><td></td><td>GND</td><td>792</td><td>793</td></tr> <tr><td></td><td>GND</td><td>794</td><td>795</td></tr> <tr><td></td><td>GND</td><td>796</td><td>797</td></tr> <tr><td></td><td>GND</td><td>798</td><td>799</td></tr> <tr><td></td><td>GND</td><td>800</td><td>801</td></tr> <tr><td></td><td>GND</td><td>802</td><td>803</td></tr> <tr><td></td><td>GND</td><td>804</td><td>805</td></tr> <tr><td></td><td>GND</td><td>806</td><td>807</td></tr> <tr><td></td><td>GND</td><td>808</td><td>809</td></tr> <tr><td></td><td>GND</td><td>810</td><td>811</td></tr> <tr><td></td><td>GND</td><td>812</td><td>813</td></tr> <tr><td></td><td>GND</td><td>814</td><td>815</td></tr> <tr><td></td><td>GND</td><td>816</td><td>817</td></tr> <tr><td></td><td>GND</td><td>818</td><td>819</td></tr> <tr><td></td><td>GND</td><td>820</td><td>821</td></tr> <tr><td></td><td>GND</td><td>822</td><td>823</td></tr> <tr><td></td><td>GND</td><td>824</td><td>825</td></tr> <tr><td></td><td>GND</td><td>826</td><td>827</td></tr> <tr><td></td><td>GND</td><td>828</td><td>829</td></tr> <tr><td></td><td>GND</td><td>830</td><td>831</td></tr> <tr><td></td><td>GND</td><td>832</td><td>833</td></tr> <tr><td></td><td>GND</td><td>834</td><td>835</td></tr> <tr><td></td><td>GND</td><td>836</td><td>837</td></tr> <tr><td></td><td>GND</td><td>838</td><td>839</td></tr> <tr><td></td><td>GND</td><td>840</td><td>841</td></tr> <tr><td></td><td>GND</td><td>842</td><td>843</td></tr> <tr><td></td><td>GND</td><td>844</td><td>845</td></tr> <tr><td></td><td>GND</td><td>846</td><td>847</td></tr> <tr><td></td><td>GND</td><td>848</td><td>849</td></tr> <tr><td></td><td>GND</td><td>850</td><td>851</td></tr> <tr><td></td><td>GND</td><td>852</td><td>853</td></tr> <tr><td></td><td>GND</td><td>854</td><td>855</td></tr> <tr><td></td><td>GND</td><td>856</td><td>857</td></tr> <tr><td></td><td>GND</td><td>858</td><td>859</td></tr> <tr><td></td><td>GND</td><td></td></tr></table></div></div>								104	SO_LAA_TO_XCVR_LAT	GND	101		GND	102	105		GND	103	106		GND	104	107	111	SO_WLAN_A_RX1_LAA	J_INT_T0P2	108		GND	109	111		GND	110	112	107	SO_WLAN_A_TX1	J_INT_T0P3	113		GND	114	116		GND	115	117	124	VPA_ET_UHB	J_INT_T0P7	118		GND	119	120	122	VPA_ZG	J_INT_T0P13	121		GND	122	123	127	VPA_ET_UHB	J_INT_T0P14	124		GND	125	126	126	VPA_ZG	J_INT_T0P15	127		GND	128	129	131	VPA_ET_UHB	J_INT_T0P16	130		GND	131	132	130	VPA_ZG	J_INT_T0P17	133		GND	134	135	140	VPA_ET_UHB	J_INT_T0P23	136		GND	137	138		GND	139	140	144	VPA_ET_UHB	J_INT_T0P24	141		GND	142	143	143	VPA_ZG	J_INT_T0P25	144		GND	145	146	157	VPA_ET_UHB	J_INT_T0P26	147		GND	148	149	153	VPA_ET_UHB	J_INT_T0P27	150		GND	151	152		GND	153	154		GND	155	156	169	GPIO_AP_CANARY1	J_INT_T0P30	157		GND	158	159		GND	160	161		GND	162	163		GND	164	165		GND	166	167		GND	168	169		GND	170	171		GND	172	173		GND	174	175		GND	176	177		GND	178	179		GND	180	181		GND	182	183		GND	184	185		GND	186	187		GND	188	189		GND	190	191		GND	192	193		GND	194	195		GND	196	197		GND	198	199		GND	200	201		GND	202	203		GND	204	205		GND	206	207		GND	208	209		GND	210	211		GND	212	213		GND	214	215		GND	216	217		GND	218	219		GND	220	221		GND	222	223		GND	224	225		GND	226	227		GND	228	229		GND	230	231		GND	232	233		GND	234	235		GND	236	237		GND	238	239		GND	240	241		GND	242	243		GND	244	245		GND	246	247		GND	248	249		GND	250	251		GND	252	253		GND	254	255		GND	256	257		GND	258	259		GND	260	261		GND	262	263		GND	264	265		GND	266	267		GND	268	269		GND	270	271		GND	272	273		GND	274	275		GND	276	277		GND	278	279		GND	280	281		GND	282	283		GND	284	285		GND	286	287		GND	288	289		GND	290	291		GND	292	293		GND	294	295		GND	296	297		GND	298	299		GND	300	301		GND	302	303		GND	304	305		GND	306	307		GND	308	309		GND	310	311		GND	312	313		GND	314	315		GND	316	317		GND	318	319		GND	320	321		GND	322	323		GND	324	325		GND	326	327		GND	328	329		GND	330	331		GND	332	333		GND	334	335		GND	336	337		GND	338	339		GND	340	341		GND	342	343		GND	344	345		GND	346	347		GND	348	349		GND	350	351		GND	352	353		GND	354	355		GND	356	357		GND	358	359		GND	360	361		GND	362	363		GND	364	365		GND	366	367		GND	368	369		GND	370	371		GND	372	373		GND	374	375		GND	376	377		GND	378	379		GND	380	381		GND	382	383		GND	384	385		GND	386	387		GND	388	389		GND	390	391		GND	392	393		GND	394	395		GND	396	397		GND	398	399		GND	400	401		GND	402	403		GND	404	405		GND	406	407		GND	408	409		GND	410	411		GND	412	413		GND	414	415		GND	416	417		GND	418	419		GND	420	421		GND	422	423		GND	424	425		GND	426	427		GND	428	429		GND	430	431		GND	432	433		GND	434	435		GND	436	437		GND	438	439		GND	440	441		GND	442	443		GND	444	445		GND	446	447		GND	448	449		GND	450	451		GND	452	453		GND	454	455		GND	456	457		GND	458	459		GND	460	461		GND	462	463		GND	464	465		GND	466	467		GND	468	469		GND	470	471		GND	472	473		GND	474	475		GND	476	477		GND	478	479		GND	480	481		GND	482	483		GND	484	485		GND	486	487		GND	488	489		GND	490	491		GND	492	493		GND	494	495		GND	496	497		GND	498	499		GND	500	501		GND	502	503		GND	504	505		GND	506	507		GND	508	509		GND	510	511		GND	512	513		GND	514	515		GND	516	517		GND	518	519		GND	520	521		GND	522	523		GND	524	525		GND	526	527		GND	528	529		GND	530	531		GND	532	533		GND	534	535		GND	536	537		GND	538	539		GND	540	541		GND	542	543		GND	544	545		GND	546	547		GND	548	549		GND	550	551		GND	552	553		GND	554	555		GND	556	557		GND	558	559		GND	560	561		GND	562	563		GND	564	565		GND	566	567		GND	568	569		GND	570	571		GND	572	573		GND	574	575		GND	576	577		GND	578	579		GND	580	581		GND	582	583		GND	584	585		GND	586	587		GND	588	589		GND	590	591		GND	592	593		GND	594	595		GND	596	597		GND	598	599		GND	600	601		GND	602	603		GND	604	605		GND	606	607		GND	608	609		GND	610	611		GND	612	613		GND	614	615		GND	616	617		GND	618	619		GND	620	621		GND	622	623		GND	624	625		GND	626	627		GND	628	629		GND	630	631		GND	632	633		GND	634	635		GND	636	637		GND	638	639		GND	640	641		GND	642	643		GND	644	645		GND	646	647		GND	648	649		GND	650	651		GND	652	653		GND	654	655		GND	656	657		GND	658	659		GND	660	661		GND	662	663		GND	664	665		GND	666	667		GND	668	669		GND	670	671		GND	672	673		GND	674	675		GND	676	677		GND	678	679		GND	680	681		GND	682	683		GND	684	685		GND	686	687		GND	688	689		GND	690	691		GND	692	693		GND	694	695		GND	696	697		GND	698	699		GND	700	701		GND	702	703		GND	704	705		GND	706	707		GND	708	709		GND	710	711		GND	712	713		GND	714	715		GND	716	717		GND	718	719		GND	720	721		GND	722	723		GND	724	725		GND	726	727		GND	728	729		GND	730	731		GND	732	733		GND	734	735		GND	736	737		GND	738	739		GND	740	741		GND	742	743		GND	744	745		GND	746	747		GND	748	749		GND	750	751		GND	752	753		GND	754	755		GND	756	757		GND	758	759		GND	760	761		GND	762	763		GND	764	765		GND	766	767		GND	768	769		GND	770	771		GND	772	773		GND	774	775		GND	776	777		GND	778	779		GND	780	781		GND	782	783		GND	784	785		GND	786	787		GND	788	789		GND	790	791		GND	792	793		GND	794	795		GND	796	797		GND	798	799		GND	800	801		GND	802	803		GND	804	805		GND	806	807		GND	808	809		GND	810	811		GND	812	813		GND	814	815		GND	816	817		GND	818	819		GND	820	821		GND	822	823		GND	824	825		GND	826	827		GND	828	829		GND	830	831		GND	832	833		GND	834	835		GND	836	837		GND	838	839		GND	840	841		GND	842	843		GND	844	845		GND	846	847		GND	848	849		GND	850	851		GND	852	853		GND	854	855		GND	856	857		GND	858	859		GND	
104	SO_LAA_TO_XCVR_LAT	GND	101																																																																																																																																																																																																																																																																																																																																																																																																																																																																																																																																																																																																																																																																																																																																																																																																																																																																																																																																																																																																																																																																																																																																																																																																																																																																																																																																																																																																																																																																																																																																																																																																																			
	GND	102	105																																																																																																																																																																																																																																																																																																																																																																																																																																																																																																																																																																																																																																																																																																																																																																																																																																																																																																																																																																																																																																																																																																																																																																																																																																																																																																																																																																																																																																																																																																																																																																																																																			
	GND	103	106																																																																																																																																																																																																																																																																																																																																																																																																																																																																																																																																																																																																																																																																																																																																																																																																																																																																																																																																																																																																																																																																																																																																																																																																																																																																																																																																																																																																																																																																																																																																																																																																																			
	GND	104	107																																																																																																																																																																																																																																																																																																																																																																																																																																																																																																																																																																																																																																																																																																																																																																																																																																																																																																																																																																																																																																																																																																																																																																																																																																																																																																																																																																																																																																																																																																																																																																																																																			
111	SO_WLAN_A_RX1_LAA	J_INT_T0P2	108																																																																																																																																																																																																																																																																																																																																																																																																																																																																																																																																																																																																																																																																																																																																																																																																																																																																																																																																																																																																																																																																																																																																																																																																																																																																																																																																																																																																																																																																																																																																																																																																																			
	GND	109	111																																																																																																																																																																																																																																																																																																																																																																																																																																																																																																																																																																																																																																																																																																																																																																																																																																																																																																																																																																																																																																																																																																																																																																																																																																																																																																																																																																																																																																																																																																																																																																																																																			
	GND	110	112																																																																																																																																																																																																																																																																																																																																																																																																																																																																																																																																																																																																																																																																																																																																																																																																																																																																																																																																																																																																																																																																																																																																																																																																																																																																																																																																																																																																																																																																																																																																																																																																																			
107	SO_WLAN_A_TX1	J_INT_T0P3	113																																																																																																																																																																																																																																																																																																																																																																																																																																																																																																																																																																																																																																																																																																																																																																																																																																																																																																																																																																																																																																																																																																																																																																																																																																																																																																																																																																																																																																																																																																																																																																																																																			
	GND	114	116																																																																																																																																																																																																																																																																																																																																																																																																																																																																																																																																																																																																																																																																																																																																																																																																																																																																																																																																																																																																																																																																																																																																																																																																																																																																																																																																																																																																																																																																																																																																																																																																																			
	GND	115	117																																																																																																																																																																																																																																																																																																																																																																																																																																																																																																																																																																																																																																																																																																																																																																																																																																																																																																																																																																																																																																																																																																																																																																																																																																																																																																																																																																																																																																																																																																																																																																																																																			
124	VPA_ET_UHB	J_INT_T0P7	118																																																																																																																																																																																																																																																																																																																																																																																																																																																																																																																																																																																																																																																																																																																																																																																																																																																																																																																																																																																																																																																																																																																																																																																																																																																																																																																																																																																																																																																																																																																																																																																																																			
	GND	119	120																																																																																																																																																																																																																																																																																																																																																																																																																																																																																																																																																																																																																																																																																																																																																																																																																																																																																																																																																																																																																																																																																																																																																																																																																																																																																																																																																																																																																																																																																																																																																																																																																			
122	VPA_ZG	J_INT_T0P13	121																																																																																																																																																																																																																																																																																																																																																																																																																																																																																																																																																																																																																																																																																																																																																																																																																																																																																																																																																																																																																																																																																																																																																																																																																																																																																																																																																																																																																																																																																																																																																																																																																			
	GND	122	123																																																																																																																																																																																																																																																																																																																																																																																																																																																																																																																																																																																																																																																																																																																																																																																																																																																																																																																																																																																																																																																																																																																																																																																																																																																																																																																																																																																																																																																																																																																																																																																																																			
127	VPA_ET_UHB	J_INT_T0P14	124																																																																																																																																																																																																																																																																																																																																																																																																																																																																																																																																																																																																																																																																																																																																																																																																																																																																																																																																																																																																																																																																																																																																																																																																																																																																																																																																																																																																																																																																																																																																																																																																																			
	GND	125	126																																																																																																																																																																																																																																																																																																																																																																																																																																																																																																																																																																																																																																																																																																																																																																																																																																																																																																																																																																																																																																																																																																																																																																																																																																																																																																																																																																																																																																																																																																																																																																																																																			
126	VPA_ZG	J_INT_T0P15	127																																																																																																																																																																																																																																																																																																																																																																																																																																																																																																																																																																																																																																																																																																																																																																																																																																																																																																																																																																																																																																																																																																																																																																																																																																																																																																																																																																																																																																																																																																																																																																																																																			
	GND	128	129																																																																																																																																																																																																																																																																																																																																																																																																																																																																																																																																																																																																																																																																																																																																																																																																																																																																																																																																																																																																																																																																																																																																																																																																																																																																																																																																																																																																																																																																																																																																																																																																																			
131	VPA_ET_UHB	J_INT_T0P16	130																																																																																																																																																																																																																																																																																																																																																																																																																																																																																																																																																																																																																																																																																																																																																																																																																																																																																																																																																																																																																																																																																																																																																																																																																																																																																																																																																																																																																																																																																																																																																																																																																			
	GND	131	132																																																																																																																																																																																																																																																																																																																																																																																																																																																																																																																																																																																																																																																																																																																																																																																																																																																																																																																																																																																																																																																																																																																																																																																																																																																																																																																																																																																																																																																																																																																																																																																																																			
130	VPA_ZG	J_INT_T0P17	133																																																																																																																																																																																																																																																																																																																																																																																																																																																																																																																																																																																																																																																																																																																																																																																																																																																																																																																																																																																																																																																																																																																																																																																																																																																																																																																																																																																																																																																																																																																																																																																																																			
	GND	134	135																																																																																																																																																																																																																																																																																																																																																																																																																																																																																																																																																																																																																																																																																																																																																																																																																																																																																																																																																																																																																																																																																																																																																																																																																																																																																																																																																																																																																																																																																																																																																																																																																			
140	VPA_ET_UHB	J_INT_T0P23	136																																																																																																																																																																																																																																																																																																																																																																																																																																																																																																																																																																																																																																																																																																																																																																																																																																																																																																																																																																																																																																																																																																																																																																																																																																																																																																																																																																																																																																																																																																																																																																																																																			
	GND	137	138																																																																																																																																																																																																																																																																																																																																																																																																																																																																																																																																																																																																																																																																																																																																																																																																																																																																																																																																																																																																																																																																																																																																																																																																																																																																																																																																																																																																																																																																																																																																																																																																																			
	GND	139	140																																																																																																																																																																																																																																																																																																																																																																																																																																																																																																																																																																																																																																																																																																																																																																																																																																																																																																																																																																																																																																																																																																																																																																																																																																																																																																																																																																																																																																																																																																																																																																																																																			
144	VPA_ET_UHB	J_INT_T0P24	141																																																																																																																																																																																																																																																																																																																																																																																																																																																																																																																																																																																																																																																																																																																																																																																																																																																																																																																																																																																																																																																																																																																																																																																																																																																																																																																																																																																																																																																																																																																																																																																																																			
	GND	142	143																																																																																																																																																																																																																																																																																																																																																																																																																																																																																																																																																																																																																																																																																																																																																																																																																																																																																																																																																																																																																																																																																																																																																																																																																																																																																																																																																																																																																																																																																																																																																																																																																			
143	VPA_ZG	J_INT_T0P25	144																																																																																																																																																																																																																																																																																																																																																																																																																																																																																																																																																																																																																																																																																																																																																																																																																																																																																																																																																																																																																																																																																																																																																																																																																																																																																																																																																																																																																																																																																																																																																																																																																			
	GND	145	146																																																																																																																																																																																																																																																																																																																																																																																																																																																																																																																																																																																																																																																																																																																																																																																																																																																																																																																																																																																																																																																																																																																																																																																																																																																																																																																																																																																																																																																																																																																																																																																																																			
157	VPA_ET_UHB	J_INT_T0P26	147																																																																																																																																																																																																																																																																																																																																																																																																																																																																																																																																																																																																																																																																																																																																																																																																																																																																																																																																																																																																																																																																																																																																																																																																																																																																																																																																																																																																																																																																																																																																																																																																																			
	GND	148	149																																																																																																																																																																																																																																																																																																																																																																																																																																																																																																																																																																																																																																																																																																																																																																																																																																																																																																																																																																																																																																																																																																																																																																																																																																																																																																																																																																																																																																																																																																																																																																																																																			
153	VPA_ET_UHB	J_INT_T0P27	150																																																																																																																																																																																																																																																																																																																																																																																																																																																																																																																																																																																																																																																																																																																																																																																																																																																																																																																																																																																																																																																																																																																																																																																																																																																																																																																																																																																																																																																																																																																																																																																																																			
	GND	151	152																																																																																																																																																																																																																																																																																																																																																																																																																																																																																																																																																																																																																																																																																																																																																																																																																																																																																																																																																																																																																																																																																																																																																																																																																																																																																																																																																																																																																																																																																																																																																																																																																			
	GND	153	154																																																																																																																																																																																																																																																																																																																																																																																																																																																																																																																																																																																																																																																																																																																																																																																																																																																																																																																																																																																																																																																																																																																																																																																																																																																																																																																																																																																																																																																																																																																																																																																																																			
	GND	155	156																																																																																																																																																																																																																																																																																																																																																																																																																																																																																																																																																																																																																																																																																																																																																																																																																																																																																																																																																																																																																																																																																																																																																																																																																																																																																																																																																																																																																																																																																																																																																																																																																			
169	GPIO_AP_CANARY1	J_INT_T0P30	157																																																																																																																																																																																																																																																																																																																																																																																																																																																																																																																																																																																																																																																																																																																																																																																																																																																																																																																																																																																																																																																																																																																																																																																																																																																																																																																																																																																																																																																																																																																																																																																																																			
	GND	158	159																																																																																																																																																																																																																																																																																																																																																																																																																																																																																																																																																																																																																																																																																																																																																																																																																																																																																																																																																																																																																																																																																																																																																																																																																																																																																																																																																																																																																																																																																																																																																																																																																			
	GND	160	161																																																																																																																																																																																																																																																																																																																																																																																																																																																																																																																																																																																																																																																																																																																																																																																																																																																																																																																																																																																																																																																																																																																																																																																																																																																																																																																																																																																																																																																																																																																																																																																																																			
	GND	162	163																																																																																																																																																																																																																																																																																																																																																																																																																																																																																																																																																																																																																																																																																																																																																																																																																																																																																																																																																																																																																																																																																																																																																																																																																																																																																																																																																																																																																																																																																																																																																																																																																			
	GND	164	165																																																																																																																																																																																																																																																																																																																																																																																																																																																																																																																																																																																																																																																																																																																																																																																																																																																																																																																																																																																																																																																																																																																																																																																																																																																																																																																																																																																																																																																																																																																																																																																																																			
	GND	166	167																																																																																																																																																																																																																																																																																																																																																																																																																																																																																																																																																																																																																																																																																																																																																																																																																																																																																																																																																																																																																																																																																																																																																																																																																																																																																																																																																																																																																																																																																																																																																																																																																			
	GND	168	169																																																																																																																																																																																																																																																																																																																																																																																																																																																																																																																																																																																																																																																																																																																																																																																																																																																																																																																																																																																																																																																																																																																																																																																																																																																																																																																																																																																																																																																																																																																																																																																																																			
	GND	170	171																																																																																																																																																																																																																																																																																																																																																																																																																																																																																																																																																																																																																																																																																																																																																																																																																																																																																																																																																																																																																																																																																																																																																																																																																																																																																																																																																																																																																																																																																																																																																																																																																			
	GND	172	173																																																																																																																																																																																																																																																																																																																																																																																																																																																																																																																																																																																																																																																																																																																																																																																																																																																																																																																																																																																																																																																																																																																																																																																																																																																																																																																																																																																																																																																																																																																																																																																																																			
	GND	174	175																																																																																																																																																																																																																																																																																																																																																																																																																																																																																																																																																																																																																																																																																																																																																																																																																																																																																																																																																																																																																																																																																																																																																																																																																																																																																																																																																																																																																																																																																																																																																																																																																			
	GND	176	177																																																																																																																																																																																																																																																																																																																																																																																																																																																																																																																																																																																																																																																																																																																																																																																																																																																																																																																																																																																																																																																																																																																																																																																																																																																																																																																																																																																																																																																																																																																																																																																																																			
	GND	178	179																																																																																																																																																																																																																																																																																																																																																																																																																																																																																																																																																																																																																																																																																																																																																																																																																																																																																																																																																																																																																																																																																																																																																																																																																																																																																																																																																																																																																																																																																																																																																																																																																			
	GND	180	181																																																																																																																																																																																																																																																																																																																																																																																																																																																																																																																																																																																																																																																																																																																																																																																																																																																																																																																																																																																																																																																																																																																																																																																																																																																																																																																																																																																																																																																																																																																																																																																																																			
	GND	182	183																																																																																																																																																																																																																																																																																																																																																																																																																																																																																																																																																																																																																																																																																																																																																																																																																																																																																																																																																																																																																																																																																																																																																																																																																																																																																																																																																																																																																																																																																																																																																																																																																			
	GND	184	185																																																																																																																																																																																																																																																																																																																																																																																																																																																																																																																																																																																																																																																																																																																																																																																																																																																																																																																																																																																																																																																																																																																																																																																																																																																																																																																																																																																																																																																																																																																																																																																																																			
	GND	186	187																																																																																																																																																																																																																																																																																																																																																																																																																																																																																																																																																																																																																																																																																																																																																																																																																																																																																																																																																																																																																																																																																																																																																																																																																																																																																																																																																																																																																																																																																																																																																																																																																			
	GND	188	189																																																																																																																																																																																																																																																																																																																																																																																																																																																																																																																																																																																																																																																																																																																																																																																																																																																																																																																																																																																																																																																																																																																																																																																																																																																																																																																																																																																																																																																																																																																																																																																																																			
	GND	190	191																																																																																																																																																																																																																																																																																																																																																																																																																																																																																																																																																																																																																																																																																																																																																																																																																																																																																																																																																																																																																																																																																																																																																																																																																																																																																																																																																																																																																																																																																																																																																																																																																			
	GND	192	193																																																																																																																																																																																																																																																																																																																																																																																																																																																																																																																																																																																																																																																																																																																																																																																																																																																																																																																																																																																																																																																																																																																																																																																																																																																																																																																																																																																																																																																																																																																																																																																																																			
	GND	194	195																																																																																																																																																																																																																																																																																																																																																																																																																																																																																																																																																																																																																																																																																																																																																																																																																																																																																																																																																																																																																																																																																																																																																																																																																																																																																																																																																																																																																																																																																																																																																																																																																			
	GND	196	197																																																																																																																																																																																																																																																																																																																																																																																																																																																																																																																																																																																																																																																																																																																																																																																																																																																																																																																																																																																																																																																																																																																																																																																																																																																																																																																																																																																																																																																																																																																																																																																																																			
	GND	198	199																																																																																																																																																																																																																																																																																																																																																																																																																																																																																																																																																																																																																																																																																																																																																																																																																																																																																																																																																																																																																																																																																																																																																																																																																																																																																																																																																																																																																																																																																																																																																																																																																			
	GND	200	201																																																																																																																																																																																																																																																																																																																																																																																																																																																																																																																																																																																																																																																																																																																																																																																																																																																																																																																																																																																																																																																																																																																																																																																																																																																																																																																																																																																																																																																																																																																																																																																																																			
	GND	202	203																																																																																																																																																																																																																																																																																																																																																																																																																																																																																																																																																																																																																																																																																																																																																																																																																																																																																																																																																																																																																																																																																																																																																																																																																																																																																																																																																																																																																																																																																																																																																																																																																			
	GND	204	205																																																																																																																																																																																																																																																																																																																																																																																																																																																																																																																																																																																																																																																																																																																																																																																																																																																																																																																																																																																																																																																																																																																																																																																																																																																																																																																																																																																																																																																																																																																																																																																																																			
	GND	206	207																																																																																																																																																																																																																																																																																																																																																																																																																																																																																																																																																																																																																																																																																																																																																																																																																																																																																																																																																																																																																																																																																																																																																																																																																																																																																																																																																																																																																																																																																																																																																																																																																			
	GND	208	209																																																																																																																																																																																																																																																																																																																																																																																																																																																																																																																																																																																																																																																																																																																																																																																																																																																																																																																																																																																																																																																																																																																																																																																																																																																																																																																																																																																																																																																																																																																																																																																																																			
	GND	210	211																																																																																																																																																																																																																																																																																																																																																																																																																																																																																																																																																																																																																																																																																																																																																																																																																																																																																																																																																																																																																																																																																																																																																																																																																																																																																																																																																																																																																																																																																																																																																																																																																			
	GND	212	213																																																																																																																																																																																																																																																																																																																																																																																																																																																																																																																																																																																																																																																																																																																																																																																																																																																																																																																																																																																																																																																																																																																																																																																																																																																																																																																																																																																																																																																																																																																																																																																																																			
	GND	214	215																																																																																																																																																																																																																																																																																																																																																																																																																																																																																																																																																																																																																																																																																																																																																																																																																																																																																																																																																																																																																																																																																																																																																																																																																																																																																																																																																																																																																																																																																																																																																																																																																			
	GND	216	217																																																																																																																																																																																																																																																																																																																																																																																																																																																																																																																																																																																																																																																																																																																																																																																																																																																																																																																																																																																																																																																																																																																																																																																																																																																																																																																																																																																																																																																																																																																																																																																																																			
	GND	218	219																																																																																																																																																																																																																																																																																																																																																																																																																																																																																																																																																																																																																																																																																																																																																																																																																																																																																																																																																																																																																																																																																																																																																																																																																																																																																																																																																																																																																																																																																																																																																																																																																			
	GND	220	221																																																																																																																																																																																																																																																																																																																																																																																																																																																																																																																																																																																																																																																																																																																																																																																																																																																																																																																																																																																																																																																																																																																																																																																																																																																																																																																																																																																																																																																																																																																																																																																																																			
	GND	222	223																																																																																																																																																																																																																																																																																																																																																																																																																																																																																																																																																																																																																																																																																																																																																																																																																																																																																																																																																																																																																																																																																																																																																																																																																																																																																																																																																																																																																																																																																																																																																																																																																			
	GND	224	225																																																																																																																																																																																																																																																																																																																																																																																																																																																																																																																																																																																																																																																																																																																																																																																																																																																																																																																																																																																																																																																																																																																																																																																																																																																																																																																																																																																																																																																																																																																																																																																																																			
	GND	226	227																																																																																																																																																																																																																																																																																																																																																																																																																																																																																																																																																																																																																																																																																																																																																																																																																																																																																																																																																																																																																																																																																																																																																																																																																																																																																																																																																																																																																																																																																																																																																																																																																			
	GND	228	229																																																																																																																																																																																																																																																																																																																																																																																																																																																																																																																																																																																																																																																																																																																																																																																																																																																																																																																																																																																																																																																																																																																																																																																																																																																																																																																																																																																																																																																																																																																																																																																																																			
	GND	230	231																																																																																																																																																																																																																																																																																																																																																																																																																																																																																																																																																																																																																																																																																																																																																																																																																																																																																																																																																																																																																																																																																																																																																																																																																																																																																																																																																																																																																																																																																																																																																																																																																			
	GND	232	233																																																																																																																																																																																																																																																																																																																																																																																																																																																																																																																																																																																																																																																																																																																																																																																																																																																																																																																																																																																																																																																																																																																																																																																																																																																																																																																																																																																																																																																																																																																																																																																																																			
	GND	234	235																																																																																																																																																																																																																																																																																																																																																																																																																																																																																																																																																																																																																																																																																																																																																																																																																																																																																																																																																																																																																																																																																																																																																																																																																																																																																																																																																																																																																																																																																																																																																																																																																			
	GND	236	237																																																																																																																																																																																																																																																																																																																																																																																																																																																																																																																																																																																																																																																																																																																																																																																																																																																																																																																																																																																																																																																																																																																																																																																																																																																																																																																																																																																																																																																																																																																																																																																																																			
	GND	238	239																																																																																																																																																																																																																																																																																																																																																																																																																																																																																																																																																																																																																																																																																																																																																																																																																																																																																																																																																																																																																																																																																																																																																																																																																																																																																																																																																																																																																																																																																																																																																																																																																			
	GND	240	241																																																																																																																																																																																																																																																																																																																																																																																																																																																																																																																																																																																																																																																																																																																																																																																																																																																																																																																																																																																																																																																																																																																																																																																																																																																																																																																																																																																																																																																																																																																																																																																																																			
	GND	242	243																																																																																																																																																																																																																																																																																																																																																																																																																																																																																																																																																																																																																																																																																																																																																																																																																																																																																																																																																																																																																																																																																																																																																																																																																																																																																																																																																																																																																																																																																																																																																																																																																			
	GND	244	245																																																																																																																																																																																																																																																																																																																																																																																																																																																																																																																																																																																																																																																																																																																																																																																																																																																																																																																																																																																																																																																																																																																																																																																																																																																																																																																																																																																																																																																																																																																																																																																																																			
	GND	246	247																																																																																																																																																																																																																																																																																																																																																																																																																																																																																																																																																																																																																																																																																																																																																																																																																																																																																																																																																																																																																																																																																																																																																																																																																																																																																																																																																																																																																																																																																																																																																																																																																			
	GND	248	249																																																																																																																																																																																																																																																																																																																																																																																																																																																																																																																																																																																																																																																																																																																																																																																																																																																																																																																																																																																																																																																																																																																																																																																																																																																																																																																																																																																																																																																																																																																																																																																																																			
	GND	250	251																																																																																																																																																																																																																																																																																																																																																																																																																																																																																																																																																																																																																																																																																																																																																																																																																																																																																																																																																																																																																																																																																																																																																																																																																																																																																																																																																																																																																																																																																																																																																																																																																			
	GND	252	253																																																																																																																																																																																																																																																																																																																																																																																																																																																																																																																																																																																																																																																																																																																																																																																																																																																																																																																																																																																																																																																																																																																																																																																																																																																																																																																																																																																																																																																																																																																																																																																																																			
	GND	254	255																																																																																																																																																																																																																																																																																																																																																																																																																																																																																																																																																																																																																																																																																																																																																																																																																																																																																																																																																																																																																																																																																																																																																																																																																																																																																																																																																																																																																																																																																																																																																																																																																			
	GND	256	257																																																																																																																																																																																																																																																																																																																																																																																																																																																																																																																																																																																																																																																																																																																																																																																																																																																																																																																																																																																																																																																																																																																																																																																																																																																																																																																																																																																																																																																																																																																																																																																																																			
	GND	258	259																																																																																																																																																																																																																																																																																																																																																																																																																																																																																																																																																																																																																																																																																																																																																																																																																																																																																																																																																																																																																																																																																																																																																																																																																																																																																																																																																																																																																																																																																																																																																																																																																			
	GND	260	261																																																																																																																																																																																																																																																																																																																																																																																																																																																																																																																																																																																																																																																																																																																																																																																																																																																																																																																																																																																																																																																																																																																																																																																																																																																																																																																																																																																																																																																																																																																																																																																																																			
	GND	262	263																																																																																																																																																																																																																																																																																																																																																																																																																																																																																																																																																																																																																																																																																																																																																																																																																																																																																																																																																																																																																																																																																																																																																																																																																																																																																																																																																																																																																																																																																																																																																																																																																			
	GND	264	265																																																																																																																																																																																																																																																																																																																																																																																																																																																																																																																																																																																																																																																																																																																																																																																																																																																																																																																																																																																																																																																																																																																																																																																																																																																																																																																																																																																																																																																																																																																																																																																																																			
	GND	266	267																																																																																																																																																																																																																																																																																																																																																																																																																																																																																																																																																																																																																																																																																																																																																																																																																																																																																																																																																																																																																																																																																																																																																																																																																																																																																																																																																																																																																																																																																																																																																																																																																			
	GND	268	269																																																																																																																																																																																																																																																																																																																																																																																																																																																																																																																																																																																																																																																																																																																																																																																																																																																																																																																																																																																																																																																																																																																																																																																																																																																																																																																																																																																																																																																																																																																																																																																																																			
	GND	270	271																																																																																																																																																																																																																																																																																																																																																																																																																																																																																																																																																																																																																																																																																																																																																																																																																																																																																																																																																																																																																																																																																																																																																																																																																																																																																																																																																																																																																																																																																																																																																																																																																			
	GND	272	273																																																																																																																																																																																																																																																																																																																																																																																																																																																																																																																																																																																																																																																																																																																																																																																																																																																																																																																																																																																																																																																																																																																																																																																																																																																																																																																																																																																																																																																																																																																																																																																																																			
	GND	274	275																																																																																																																																																																																																																																																																																																																																																																																																																																																																																																																																																																																																																																																																																																																																																																																																																																																																																																																																																																																																																																																																																																																																																																																																																																																																																																																																																																																																																																																																																																																																																																																																																			
	GND	276	277																																																																																																																																																																																																																																																																																																																																																																																																																																																																																																																																																																																																																																																																																																																																																																																																																																																																																																																																																																																																																																																																																																																																																																																																																																																																																																																																																																																																																																																																																																																																																																																																																			
	GND	278	279																																																																																																																																																																																																																																																																																																																																																																																																																																																																																																																																																																																																																																																																																																																																																																																																																																																																																																																																																																																																																																																																																																																																																																																																																																																																																																																																																																																																																																																																																																																																																																																																																			
	GND	280	281																																																																																																																																																																																																																																																																																																																																																																																																																																																																																																																																																																																																																																																																																																																																																																																																																																																																																																																																																																																																																																																																																																																																																																																																																																																																																																																																																																																																																																																																																																																																																																																																																			
	GND	282	283																																																																																																																																																																																																																																																																																																																																																																																																																																																																																																																																																																																																																																																																																																																																																																																																																																																																																																																																																																																																																																																																																																																																																																																																																																																																																																																																																																																																																																																																																																																																																																																																																			
	GND	284	285																																																																																																																																																																																																																																																																																																																																																																																																																																																																																																																																																																																																																																																																																																																																																																																																																																																																																																																																																																																																																																																																																																																																																																																																																																																																																																																																																																																																																																																																																																																																																																																																																			
	GND	286	287																																																																																																																																																																																																																																																																																																																																																																																																																																																																																																																																																																																																																																																																																																																																																																																																																																																																																																																																																																																																																																																																																																																																																																																																																																																																																																																																																																																																																																																																																																																																																																																																																			
	GND	288	289																																																																																																																																																																																																																																																																																																																																																																																																																																																																																																																																																																																																																																																																																																																																																																																																																																																																																																																																																																																																																																																																																																																																																																																																																																																																																																																																																																																																																																																																																																																																																																																																																			
	GND	290	291																																																																																																																																																																																																																																																																																																																																																																																																																																																																																																																																																																																																																																																																																																																																																																																																																																																																																																																																																																																																																																																																																																																																																																																																																																																																																																																																																																																																																																																																																																																																																																																																																			
	GND	292	293																																																																																																																																																																																																																																																																																																																																																																																																																																																																																																																																																																																																																																																																																																																																																																																																																																																																																																																																																																																																																																																																																																																																																																																																																																																																																																																																																																																																																																																																																																																																																																																																																			
	GND	294	295																																																																																																																																																																																																																																																																																																																																																																																																																																																																																																																																																																																																																																																																																																																																																																																																																																																																																																																																																																																																																																																																																																																																																																																																																																																																																																																																																																																																																																																																																																																																																																																																																			
	GND	296	297																																																																																																																																																																																																																																																																																																																																																																																																																																																																																																																																																																																																																																																																																																																																																																																																																																																																																																																																																																																																																																																																																																																																																																																																																																																																																																																																																																																																																																																																																																																																																																																																																			
	GND	298	299																																																																																																																																																																																																																																																																																																																																																																																																																																																																																																																																																																																																																																																																																																																																																																																																																																																																																																																																																																																																																																																																																																																																																																																																																																																																																																																																																																																																																																																																																																																																																																																																																			
	GND	300	301																																																																																																																																																																																																																																																																																																																																																																																																																																																																																																																																																																																																																																																																																																																																																																																																																																																																																																																																																																																																																																																																																																																																																																																																																																																																																																																																																																																																																																																																																																																																																																																																																			
	GND	302	303																																																																																																																																																																																																																																																																																																																																																																																																																																																																																																																																																																																																																																																																																																																																																																																																																																																																																																																																																																																																																																																																																																																																																																																																																																																																																																																																																																																																																																																																																																																																																																																																																			
	GND	304	305																																																																																																																																																																																																																																																																																																																																																																																																																																																																																																																																																																																																																																																																																																																																																																																																																																																																																																																																																																																																																																																																																																																																																																																																																																																																																																																																																																																																																																																																																																																																																																																																																			
	GND	306	307																																																																																																																																																																																																																																																																																																																																																																																																																																																																																																																																																																																																																																																																																																																																																																																																																																																																																																																																																																																																																																																																																																																																																																																																																																																																																																																																																																																																																																																																																																																																																																																																																			
	GND	308	309																																																																																																																																																																																																																																																																																																																																																																																																																																																																																																																																																																																																																																																																																																																																																																																																																																																																																																																																																																																																																																																																																																																																																																																																																																																																																																																																																																																																																																																																																																																																																																																																																			
	GND	310	311																																																																																																																																																																																																																																																																																																																																																																																																																																																																																																																																																																																																																																																																																																																																																																																																																																																																																																																																																																																																																																																																																																																																																																																																																																																																																																																																																																																																																																																																																																																																																																																																																			
	GND	312	313																																																																																																																																																																																																																																																																																																																																																																																																																																																																																																																																																																																																																																																																																																																																																																																																																																																																																																																																																																																																																																																																																																																																																																																																																																																																																																																																																																																																																																																																																																																																																																																																																			
	GND	314	315																																																																																																																																																																																																																																																																																																																																																																																																																																																																																																																																																																																																																																																																																																																																																																																																																																																																																																																																																																																																																																																																																																																																																																																																																																																																																																																																																																																																																																																																																																																																																																																																																			
	GND	316	317																																																																																																																																																																																																																																																																																																																																																																																																																																																																																																																																																																																																																																																																																																																																																																																																																																																																																																																																																																																																																																																																																																																																																																																																																																																																																																																																																																																																																																																																																																																																																																																																																			
	GND	318	319																																																																																																																																																																																																																																																																																																																																																																																																																																																																																																																																																																																																																																																																																																																																																																																																																																																																																																																																																																																																																																																																																																																																																																																																																																																																																																																																																																																																																																																																																																																																																																																																																			
	GND	320	321																																																																																																																																																																																																																																																																																																																																																																																																																																																																																																																																																																																																																																																																																																																																																																																																																																																																																																																																																																																																																																																																																																																																																																																																																																																																																																																																																																																																																																																																																																																																																																																																																			
	GND	322	323																																																																																																																																																																																																																																																																																																																																																																																																																																																																																																																																																																																																																																																																																																																																																																																																																																																																																																																																																																																																																																																																																																																																																																																																																																																																																																																																																																																																																																																																																																																																																																																																																			
	GND	324	325																																																																																																																																																																																																																																																																																																																																																																																																																																																																																																																																																																																																																																																																																																																																																																																																																																																																																																																																																																																																																																																																																																																																																																																																																																																																																																																																																																																																																																																																																																																																																																																																																			
	GND	326	327																																																																																																																																																																																																																																																																																																																																																																																																																																																																																																																																																																																																																																																																																																																																																																																																																																																																																																																																																																																																																																																																																																																																																																																																																																																																																																																																																																																																																																																																																																																																																																																																																			
	GND	328	329																																																																																																																																																																																																																																																																																																																																																																																																																																																																																																																																																																																																																																																																																																																																																																																																																																																																																																																																																																																																																																																																																																																																																																																																																																																																																																																																																																																																																																																																																																																																																																																																																			
	GND	330	331																																																																																																																																																																																																																																																																																																																																																																																																																																																																																																																																																																																																																																																																																																																																																																																																																																																																																																																																																																																																																																																																																																																																																																																																																																																																																																																																																																																																																																																																																																																																																																																																																			
	GND	332	333																																																																																																																																																																																																																																																																																																																																																																																																																																																																																																																																																																																																																																																																																																																																																																																																																																																																																																																																																																																																																																																																																																																																																																																																																																																																																																																																																																																																																																																																																																																																																																																																																			
	GND	334	335																																																																																																																																																																																																																																																																																																																																																																																																																																																																																																																																																																																																																																																																																																																																																																																																																																																																																																																																																																																																																																																																																																																																																																																																																																																																																																																																																																																																																																																																																																																																																																																																																			
	GND	336	337																																																																																																																																																																																																																																																																																																																																																																																																																																																																																																																																																																																																																																																																																																																																																																																																																																																																																																																																																																																																																																																																																																																																																																																																																																																																																																																																																																																																																																																																																																																																																																																																																			
	GND	338	339																																																																																																																																																																																																																																																																																																																																																																																																																																																																																																																																																																																																																																																																																																																																																																																																																																																																																																																																																																																																																																																																																																																																																																																																																																																																																																																																																																																																																																																																																																																																																																																																																			
	GND	340	341																																																																																																																																																																																																																																																																																																																																																																																																																																																																																																																																																																																																																																																																																																																																																																																																																																																																																																																																																																																																																																																																																																																																																																																																																																																																																																																																																																																																																																																																																																																																																																																																																			
	GND	342	343																																																																																																																																																																																																																																																																																																																																																																																																																																																																																																																																																																																																																																																																																																																																																																																																																																																																																																																																																																																																																																																																																																																																																																																																																																																																																																																																																																																																																																																																																																																																																																																																																			
	GND	344	345																																																																																																																																																																																																																																																																																																																																																																																																																																																																																																																																																																																																																																																																																																																																																																																																																																																																																																																																																																																																																																																																																																																																																																																																																																																																																																																																																																																																																																																																																																																																																																																																																			
	GND	346	347																																																																																																																																																																																																																																																																																																																																																																																																																																																																																																																																																																																																																																																																																																																																																																																																																																																																																																																																																																																																																																																																																																																																																																																																																																																																																																																																																																																																																																																																																																																																																																																																																			
	GND	348	349																																																																																																																																																																																																																																																																																																																																																																																																																																																																																																																																																																																																																																																																																																																																																																																																																																																																																																																																																																																																																																																																																																																																																																																																																																																																																																																																																																																																																																																																																																																																																																																																																			
	GND	350	351																																																																																																																																																																																																																																																																																																																																																																																																																																																																																																																																																																																																																																																																																																																																																																																																																																																																																																																																																																																																																																																																																																																																																																																																																																																																																																																																																																																																																																																																																																																																																																																																																			
	GND	352	353																																																																																																																																																																																																																																																																																																																																																																																																																																																																																																																																																																																																																																																																																																																																																																																																																																																																																																																																																																																																																																																																																																																																																																																																																																																																																																																																																																																																																																																																																																																																																																																																																			
	GND	354	355																																																																																																																																																																																																																																																																																																																																																																																																																																																																																																																																																																																																																																																																																																																																																																																																																																																																																																																																																																																																																																																																																																																																																																																																																																																																																																																																																																																																																																																																																																																																																																																																																			
	GND	356	357																																																																																																																																																																																																																																																																																																																																																																																																																																																																																																																																																																																																																																																																																																																																																																																																																																																																																																																																																																																																																																																																																																																																																																																																																																																																																																																																																																																																																																																																																																																																																																																																																			
	GND	358	359																																																																																																																																																																																																																																																																																																																																																																																																																																																																																																																																																																																																																																																																																																																																																																																																																																																																																																																																																																																																																																																																																																																																																																																																																																																																																																																																																																																																																																																																																																																																																																																																																			
	GND	360	361																																																																																																																																																																																																																																																																																																																																																																																																																																																																																																																																																																																																																																																																																																																																																																																																																																																																																																																																																																																																																																																																																																																																																																																																																																																																																																																																																																																																																																																																																																																																																																																																																			
	GND	362	363																																																																																																																																																																																																																																																																																																																																																																																																																																																																																																																																																																																																																																																																																																																																																																																																																																																																																																																																																																																																																																																																																																																																																																																																																																																																																																																																																																																																																																																																																																																																																																																																																			
	GND	364	365																																																																																																																																																																																																																																																																																																																																																																																																																																																																																																																																																																																																																																																																																																																																																																																																																																																																																																																																																																																																																																																																																																																																																																																																																																																																																																																																																																																																																																																																																																																																																																																																																			
	GND	366	367																																																																																																																																																																																																																																																																																																																																																																																																																																																																																																																																																																																																																																																																																																																																																																																																																																																																																																																																																																																																																																																																																																																																																																																																																																																																																																																																																																																																																																																																																																																																																																																																																			
	GND	368	369																																																																																																																																																																																																																																																																																																																																																																																																																																																																																																																																																																																																																																																																																																																																																																																																																																																																																																																																																																																																																																																																																																																																																																																																																																																																																																																																																																																																																																																																																																																																																																																																																			
	GND	370	371																																																																																																																																																																																																																																																																																																																																																																																																																																																																																																																																																																																																																																																																																																																																																																																																																																																																																																																																																																																																																																																																																																																																																																																																																																																																																																																																																																																																																																																																																																																																																																																																																			
	GND	372	373																																																																																																																																																																																																																																																																																																																																																																																																																																																																																																																																																																																																																																																																																																																																																																																																																																																																																																																																																																																																																																																																																																																																																																																																																																																																																																																																																																																																																																																																																																																																																																																																																			
	GND	374	375																																																																																																																																																																																																																																																																																																																																																																																																																																																																																																																																																																																																																																																																																																																																																																																																																																																																																																																																																																																																																																																																																																																																																																																																																																																																																																																																																																																																																																																																																																																																																																																																																			
	GND	376	377																																																																																																																																																																																																																																																																																																																																																																																																																																																																																																																																																																																																																																																																																																																																																																																																																																																																																																																																																																																																																																																																																																																																																																																																																																																																																																																																																																																																																																																																																																																																																																																																																			
	GND	378	379																																																																																																																																																																																																																																																																																																																																																																																																																																																																																																																																																																																																																																																																																																																																																																																																																																																																																																																																																																																																																																																																																																																																																																																																																																																																																																																																																																																																																																																																																																																																																																																																																			
	GND	380	381																																																																																																																																																																																																																																																																																																																																																																																																																																																																																																																																																																																																																																																																																																																																																																																																																																																																																																																																																																																																																																																																																																																																																																																																																																																																																																																																																																																																																																																																																																																																																																																																																			
	GND	382	383																																																																																																																																																																																																																																																																																																																																																																																																																																																																																																																																																																																																																																																																																																																																																																																																																																																																																																																																																																																																																																																																																																																																																																																																																																																																																																																																																																																																																																																																																																																																																																																																																			
	GND	384	385																																																																																																																																																																																																																																																																																																																																																																																																																																																																																																																																																																																																																																																																																																																																																																																																																																																																																																																																																																																																																																																																																																																																																																																																																																																																																																																																																																																																																																																																																																																																																																																																																			
	GND	386	387																																																																																																																																																																																																																																																																																																																																																																																																																																																																																																																																																																																																																																																																																																																																																																																																																																																																																																																																																																																																																																																																																																																																																																																																																																																																																																																																																																																																																																																																																																																																																																																																																			
	GND	388	389																																																																																																																																																																																																																																																																																																																																																																																																																																																																																																																																																																																																																																																																																																																																																																																																																																																																																																																																																																																																																																																																																																																																																																																																																																																																																																																																																																																																																																																																																																																																																																																																																			
	GND	390	391																																																																																																																																																																																																																																																																																																																																																																																																																																																																																																																																																																																																																																																																																																																																																																																																																																																																																																																																																																																																																																																																																																																																																																																																																																																																																																																																																																																																																																																																																																																																																																																																																			
	GND	392	393																																																																																																																																																																																																																																																																																																																																																																																																																																																																																																																																																																																																																																																																																																																																																																																																																																																																																																																																																																																																																																																																																																																																																																																																																																																																																																																																																																																																																																																																																																																																																																																																																			
	GND	394	395																																																																																																																																																																																																																																																																																																																																																																																																																																																																																																																																																																																																																																																																																																																																																																																																																																																																																																																																																																																																																																																																																																																																																																																																																																																																																																																																																																																																																																																																																																																																																																																																																			
	GND	396	397																																																																																																																																																																																																																																																																																																																																																																																																																																																																																																																																																																																																																																																																																																																																																																																																																																																																																																																																																																																																																																																																																																																																																																																																																																																																																																																																																																																																																																																																																																																																																																																																																			
	GND	398	399																																																																																																																																																																																																																																																																																																																																																																																																																																																																																																																																																																																																																																																																																																																																																																																																																																																																																																																																																																																																																																																																																																																																																																																																																																																																																																																																																																																																																																																																																																																																																																																																																			
	GND	400	401																																																																																																																																																																																																																																																																																																																																																																																																																																																																																																																																																																																																																																																																																																																																																																																																																																																																																																																																																																																																																																																																																																																																																																																																																																																																																																																																																																																																																																																																																																																																																																																																																			
	GND	402	403																																																																																																																																																																																																																																																																																																																																																																																																																																																																																																																																																																																																																																																																																																																																																																																																																																																																																																																																																																																																																																																																																																																																																																																																																																																																																																																																																																																																																																																																																																																																																																																																																			
	GND	404	405																																																																																																																																																																																																																																																																																																																																																																																																																																																																																																																																																																																																																																																																																																																																																																																																																																																																																																																																																																																																																																																																																																																																																																																																																																																																																																																																																																																																																																																																																																																																																																																																																			
	GND	406	407																																																																																																																																																																																																																																																																																																																																																																																																																																																																																																																																																																																																																																																																																																																																																																																																																																																																																																																																																																																																																																																																																																																																																																																																																																																																																																																																																																																																																																																																																																																																																																																																																			
	GND	408	409																																																																																																																																																																																																																																																																																																																																																																																																																																																																																																																																																																																																																																																																																																																																																																																																																																																																																																																																																																																																																																																																																																																																																																																																																																																																																																																																																																																																																																																																																																																																																																																																																			
	GND	410	411																																																																																																																																																																																																																																																																																																																																																																																																																																																																																																																																																																																																																																																																																																																																																																																																																																																																																																																																																																																																																																																																																																																																																																																																																																																																																																																																																																																																																																																																																																																																																																																																																			
	GND	412	413																																																																																																																																																																																																																																																																																																																																																																																																																																																																																																																																																																																																																																																																																																																																																																																																																																																																																																																																																																																																																																																																																																																																																																																																																																																																																																																																																																																																																																																																																																																																																																																																																			
	GND	414	415																																																																																																																																																																																																																																																																																																																																																																																																																																																																																																																																																																																																																																																																																																																																																																																																																																																																																																																																																																																																																																																																																																																																																																																																																																																																																																																																																																																																																																																																																																																																																																																																																			
	GND	416	417																																																																																																																																																																																																																																																																																																																																																																																																																																																																																																																																																																																																																																																																																																																																																																																																																																																																																																																																																																																																																																																																																																																																																																																																																																																																																																																																																																																																																																																																																																																																																																																																																			
	GND	418	419																																																																																																																																																																																																																																																																																																																																																																																																																																																																																																																																																																																																																																																																																																																																																																																																																																																																																																																																																																																																																																																																																																																																																																																																																																																																																																																																																																																																																																																																																																																																																																																																																			
	GND	420	421																																																																																																																																																																																																																																																																																																																																																																																																																																																																																																																																																																																																																																																																																																																																																																																																																																																																																																																																																																																																																																																																																																																																																																																																																																																																																																																																																																																																																																																																																																																																																																																																																			
	GND	422	423																																																																																																																																																																																																																																																																																																																																																																																																																																																																																																																																																																																																																																																																																																																																																																																																																																																																																																																																																																																																																																																																																																																																																																																																																																																																																																																																																																																																																																																																																																																																																																																																																			
	GND	424	425																																																																																																																																																																																																																																																																																																																																																																																																																																																																																																																																																																																																																																																																																																																																																																																																																																																																																																																																																																																																																																																																																																																																																																																																																																																																																																																																																																																																																																																																																																																																																																																																																			
	GND	426	427																																																																																																																																																																																																																																																																																																																																																																																																																																																																																																																																																																																																																																																																																																																																																																																																																																																																																																																																																																																																																																																																																																																																																																																																																																																																																																																																																																																																																																																																																																																																																																																																																			
	GND	428	429																																																																																																																																																																																																																																																																																																																																																																																																																																																																																																																																																																																																																																																																																																																																																																																																																																																																																																																																																																																																																																																																																																																																																																																																																																																																																																																																																																																																																																																																																																																																																																																																																			
	GND	430	431																																																																																																																																																																																																																																																																																																																																																																																																																																																																																																																																																																																																																																																																																																																																																																																																																																																																																																																																																																																																																																																																																																																																																																																																																																																																																																																																																																																																																																																																																																																																																																																																																			
	GND	432	433																																																																																																																																																																																																																																																																																																																																																																																																																																																																																																																																																																																																																																																																																																																																																																																																																																																																																																																																																																																																																																																																																																																																																																																																																																																																																																																																																																																																																																																																																																																																																																																																																			
	GND	434	435																																																																																																																																																																																																																																																																																																																																																																																																																																																																																																																																																																																																																																																																																																																																																																																																																																																																																																																																																																																																																																																																																																																																																																																																																																																																																																																																																																																																																																																																																																																																																																																																																			
	GND	436	437																																																																																																																																																																																																																																																																																																																																																																																																																																																																																																																																																																																																																																																																																																																																																																																																																																																																																																																																																																																																																																																																																																																																																																																																																																																																																																																																																																																																																																																																																																																																																																																																																			
	GND	438	439																																																																																																																																																																																																																																																																																																																																																																																																																																																																																																																																																																																																																																																																																																																																																																																																																																																																																																																																																																																																																																																																																																																																																																																																																																																																																																																																																																																																																																																																																																																																																																																																																			
	GND	440	441																																																																																																																																																																																																																																																																																																																																																																																																																																																																																																																																																																																																																																																																																																																																																																																																																																																																																																																																																																																																																																																																																																																																																																																																																																																																																																																																																																																																																																																																																																																																																																																																																			
	GND	442	443																																																																																																																																																																																																																																																																																																																																																																																																																																																																																																																																																																																																																																																																																																																																																																																																																																																																																																																																																																																																																																																																																																																																																																																																																																																																																																																																																																																																																																																																																																																																																																																																																			
	GND	444	445																																																																																																																																																																																																																																																																																																																																																																																																																																																																																																																																																																																																																																																																																																																																																																																																																																																																																																																																																																																																																																																																																																																																																																																																																																																																																																																																																																																																																																																																																																																																																																																																																			
	GND	446	447																																																																																																																																																																																																																																																																																																																																																																																																																																																																																																																																																																																																																																																																																																																																																																																																																																																																																																																																																																																																																																																																																																																																																																																																																																																																																																																																																																																																																																																																																																																																																																																																																			
	GND	448	449																																																																																																																																																																																																																																																																																																																																																																																																																																																																																																																																																																																																																																																																																																																																																																																																																																																																																																																																																																																																																																																																																																																																																																																																																																																																																																																																																																																																																																																																																																																																																																																																																			
	GND	450	451																																																																																																																																																																																																																																																																																																																																																																																																																																																																																																																																																																																																																																																																																																																																																																																																																																																																																																																																																																																																																																																																																																																																																																																																																																																																																																																																																																																																																																																																																																																																																																																																																			
	GND	452	453																																																																																																																																																																																																																																																																																																																																																																																																																																																																																																																																																																																																																																																																																																																																																																																																																																																																																																																																																																																																																																																																																																																																																																																																																																																																																																																																																																																																																																																																																																																																																																																																																			
	GND	454	455																																																																																																																																																																																																																																																																																																																																																																																																																																																																																																																																																																																																																																																																																																																																																																																																																																																																																																																																																																																																																																																																																																																																																																																																																																																																																																																																																																																																																																																																																																																																																																																																																			
	GND	456	457																																																																																																																																																																																																																																																																																																																																																																																																																																																																																																																																																																																																																																																																																																																																																																																																																																																																																																																																																																																																																																																																																																																																																																																																																																																																																																																																																																																																																																																																																																																																																																																																																			
	GND	458	459																																																																																																																																																																																																																																																																																																																																																																																																																																																																																																																																																																																																																																																																																																																																																																																																																																																																																																																																																																																																																																																																																																																																																																																																																																																																																																																																																																																																																																																																																																																																																																																																																			
	GND	460	461																																																																																																																																																																																																																																																																																																																																																																																																																																																																																																																																																																																																																																																																																																																																																																																																																																																																																																																																																																																																																																																																																																																																																																																																																																																																																																																																																																																																																																																																																																																																																																																																																			
	GND	462	463																																																																																																																																																																																																																																																																																																																																																																																																																																																																																																																																																																																																																																																																																																																																																																																																																																																																																																																																																																																																																																																																																																																																																																																																																																																																																																																																																																																																																																																																																																																																																																																																																			
	GND	464	465																																																																																																																																																																																																																																																																																																																																																																																																																																																																																																																																																																																																																																																																																																																																																																																																																																																																																																																																																																																																																																																																																																																																																																																																																																																																																																																																																																																																																																																																																																																																																																																																																			
	GND	466	467																																																																																																																																																																																																																																																																																																																																																																																																																																																																																																																																																																																																																																																																																																																																																																																																																																																																																																																																																																																																																																																																																																																																																																																																																																																																																																																																																																																																																																																																																																																																																																																																																			
	GND	468	469																																																																																																																																																																																																																																																																																																																																																																																																																																																																																																																																																																																																																																																																																																																																																																																																																																																																																																																																																																																																																																																																																																																																																																																																																																																																																																																																																																																																																																																																																																																																																																																																																			
	GND	470	471																																																																																																																																																																																																																																																																																																																																																																																																																																																																																																																																																																																																																																																																																																																																																																																																																																																																																																																																																																																																																																																																																																																																																																																																																																																																																																																																																																																																																																																																																																																																																																																																																			
	GND	472	473																																																																																																																																																																																																																																																																																																																																																																																																																																																																																																																																																																																																																																																																																																																																																																																																																																																																																																																																																																																																																																																																																																																																																																																																																																																																																																																																																																																																																																																																																																																																																																																																																			
	GND	474	475																																																																																																																																																																																																																																																																																																																																																																																																																																																																																																																																																																																																																																																																																																																																																																																																																																																																																																																																																																																																																																																																																																																																																																																																																																																																																																																																																																																																																																																																																																																																																																																																																			
	GND	476	477																																																																																																																																																																																																																																																																																																																																																																																																																																																																																																																																																																																																																																																																																																																																																																																																																																																																																																																																																																																																																																																																																																																																																																																																																																																																																																																																																																																																																																																																																																																																																																																																																			
	GND	478	479																																																																																																																																																																																																																																																																																																																																																																																																																																																																																																																																																																																																																																																																																																																																																																																																																																																																																																																																																																																																																																																																																																																																																																																																																																																																																																																																																																																																																																																																																																																																																																																																																			
	GND	480	481																																																																																																																																																																																																																																																																																																																																																																																																																																																																																																																																																																																																																																																																																																																																																																																																																																																																																																																																																																																																																																																																																																																																																																																																																																																																																																																																																																																																																																																																																																																																																																																																																			
	GND	482	483																																																																																																																																																																																																																																																																																																																																																																																																																																																																																																																																																																																																																																																																																																																																																																																																																																																																																																																																																																																																																																																																																																																																																																																																																																																																																																																																																																																																																																																																																																																																																																																																																			
	GND	484	485																																																																																																																																																																																																																																																																																																																																																																																																																																																																																																																																																																																																																																																																																																																																																																																																																																																																																																																																																																																																																																																																																																																																																																																																																																																																																																																																																																																																																																																																																																																																																																																																																			
	GND	486	487																																																																																																																																																																																																																																																																																																																																																																																																																																																																																																																																																																																																																																																																																																																																																																																																																																																																																																																																																																																																																																																																																																																																																																																																																																																																																																																																																																																																																																																																																																																																																																																																																			
	GND	488	489																																																																																																																																																																																																																																																																																																																																																																																																																																																																																																																																																																																																																																																																																																																																																																																																																																																																																																																																																																																																																																																																																																																																																																																																																																																																																																																																																																																																																																																																																																																																																																																																																			
	GND	490	491																																																																																																																																																																																																																																																																																																																																																																																																																																																																																																																																																																																																																																																																																																																																																																																																																																																																																																																																																																																																																																																																																																																																																																																																																																																																																																																																																																																																																																																																																																																																																																																																																			
	GND	492	493																																																																																																																																																																																																																																																																																																																																																																																																																																																																																																																																																																																																																																																																																																																																																																																																																																																																																																																																																																																																																																																																																																																																																																																																																																																																																																																																																																																																																																																																																																																																																																																																																			
	GND	494	495																																																																																																																																																																																																																																																																																																																																																																																																																																																																																																																																																																																																																																																																																																																																																																																																																																																																																																																																																																																																																																																																																																																																																																																																																																																																																																																																																																																																																																																																																																																																																																																																																			
	GND	496	497																																																																																																																																																																																																																																																																																																																																																																																																																																																																																																																																																																																																																																																																																																																																																																																																																																																																																																																																																																																																																																																																																																																																																																																																																																																																																																																																																																																																																																																																																																																																																																																																																			
	GND	498	499																																																																																																																																																																																																																																																																																																																																																																																																																																																																																																																																																																																																																																																																																																																																																																																																																																																																																																																																																																																																																																																																																																																																																																																																																																																																																																																																																																																																																																																																																																																																																																																																																			
	GND	500	501																																																																																																																																																																																																																																																																																																																																																																																																																																																																																																																																																																																																																																																																																																																																																																																																																																																																																																																																																																																																																																																																																																																																																																																																																																																																																																																																																																																																																																																																																																																																																																																																																			
	GND	502	503																																																																																																																																																																																																																																																																																																																																																																																																																																																																																																																																																																																																																																																																																																																																																																																																																																																																																																																																																																																																																																																																																																																																																																																																																																																																																																																																																																																																																																																																																																																																																																																																																			
	GND	504	505																																																																																																																																																																																																																																																																																																																																																																																																																																																																																																																																																																																																																																																																																																																																																																																																																																																																																																																																																																																																																																																																																																																																																																																																																																																																																																																																																																																																																																																																																																																																																																																																																			
	GND	506	507																																																																																																																																																																																																																																																																																																																																																																																																																																																																																																																																																																																																																																																																																																																																																																																																																																																																																																																																																																																																																																																																																																																																																																																																																																																																																																																																																																																																																																																																																																																																																																																																																			
	GND	508	509																																																																																																																																																																																																																																																																																																																																																																																																																																																																																																																																																																																																																																																																																																																																																																																																																																																																																																																																																																																																																																																																																																																																																																																																																																																																																																																																																																																																																																																																																																																																																																																																																			
	GND	510	511																																																																																																																																																																																																																																																																																																																																																																																																																																																																																																																																																																																																																																																																																																																																																																																																																																																																																																																																																																																																																																																																																																																																																																																																																																																																																																																																																																																																																																																																																																																																																																																																																			
	GND	512	513																																																																																																																																																																																																																																																																																																																																																																																																																																																																																																																																																																																																																																																																																																																																																																																																																																																																																																																																																																																																																																																																																																																																																																																																																																																																																																																																																																																																																																																																																																																																																																																																																			
	GND	514	515																																																																																																																																																																																																																																																																																																																																																																																																																																																																																																																																																																																																																																																																																																																																																																																																																																																																																																																																																																																																																																																																																																																																																																																																																																																																																																																																																																																																																																																																																																																																																																																																																			
	GND	516	517																																																																																																																																																																																																																																																																																																																																																																																																																																																																																																																																																																																																																																																																																																																																																																																																																																																																																																																																																																																																																																																																																																																																																																																																																																																																																																																																																																																																																																																																																																																																																																																																																			
	GND	518	519																																																																																																																																																																																																																																																																																																																																																																																																																																																																																																																																																																																																																																																																																																																																																																																																																																																																																																																																																																																																																																																																																																																																																																																																																																																																																																																																																																																																																																																																																																																																																																																																																			
	GND	520	521																																																																																																																																																																																																																																																																																																																																																																																																																																																																																																																																																																																																																																																																																																																																																																																																																																																																																																																																																																																																																																																																																																																																																																																																																																																																																																																																																																																																																																																																																																																																																																																																																			
	GND	522	523																																																																																																																																																																																																																																																																																																																																																																																																																																																																																																																																																																																																																																																																																																																																																																																																																																																																																																																																																																																																																																																																																																																																																																																																																																																																																																																																																																																																																																																																																																																																																																																																																			
	GND	524	525																																																																																																																																																																																																																																																																																																																																																																																																																																																																																																																																																																																																																																																																																																																																																																																																																																																																																																																																																																																																																																																																																																																																																																																																																																																																																																																																																																																																																																																																																																																																																																																																																			
	GND	526	527																																																																																																																																																																																																																																																																																																																																																																																																																																																																																																																																																																																																																																																																																																																																																																																																																																																																																																																																																																																																																																																																																																																																																																																																																																																																																																																																																																																																																																																																																																																																																																																																																			
	GND	528	529																																																																																																																																																																																																																																																																																																																																																																																																																																																																																																																																																																																																																																																																																																																																																																																																																																																																																																																																																																																																																																																																																																																																																																																																																																																																																																																																																																																																																																																																																																																																																																																																																			
	GND	530	531																																																																																																																																																																																																																																																																																																																																																																																																																																																																																																																																																																																																																																																																																																																																																																																																																																																																																																																																																																																																																																																																																																																																																																																																																																																																																																																																																																																																																																																																																																																																																																																																																			
	GND	532	533																																																																																																																																																																																																																																																																																																																																																																																																																																																																																																																																																																																																																																																																																																																																																																																																																																																																																																																																																																																																																																																																																																																																																																																																																																																																																																																																																																																																																																																																																																																																																																																																																			
	GND	534	535																																																																																																																																																																																																																																																																																																																																																																																																																																																																																																																																																																																																																																																																																																																																																																																																																																																																																																																																																																																																																																																																																																																																																																																																																																																																																																																																																																																																																																																																																																																																																																																																																			
	GND	536	537																																																																																																																																																																																																																																																																																																																																																																																																																																																																																																																																																																																																																																																																																																																																																																																																																																																																																																																																																																																																																																																																																																																																																																																																																																																																																																																																																																																																																																																																																																																																																																																																																			
	GND	538	539																																																																																																																																																																																																																																																																																																																																																																																																																																																																																																																																																																																																																																																																																																																																																																																																																																																																																																																																																																																																																																																																																																																																																																																																																																																																																																																																																																																																																																																																																																																																																																																																																			
	GND	540	541																																																																																																																																																																																																																																																																																																																																																																																																																																																																																																																																																																																																																																																																																																																																																																																																																																																																																																																																																																																																																																																																																																																																																																																																																																																																																																																																																																																																																																																																																																																																																																																																																			
	GND	542	543																																																																																																																																																																																																																																																																																																																																																																																																																																																																																																																																																																																																																																																																																																																																																																																																																																																																																																																																																																																																																																																																																																																																																																																																																																																																																																																																																																																																																																																																																																																																																																																																																			
	GND	544	545																																																																																																																																																																																																																																																																																																																																																																																																																																																																																																																																																																																																																																																																																																																																																																																																																																																																																																																																																																																																																																																																																																																																																																																																																																																																																																																																																																																																																																																																																																																																																																																																																			
	GND	546	547																																																																																																																																																																																																																																																																																																																																																																																																																																																																																																																																																																																																																																																																																																																																																																																																																																																																																																																																																																																																																																																																																																																																																																																																																																																																																																																																																																																																																																																																																																																																																																																																																			
	GND	548	549																																																																																																																																																																																																																																																																																																																																																																																																																																																																																																																																																																																																																																																																																																																																																																																																																																																																																																																																																																																																																																																																																																																																																																																																																																																																																																																																																																																																																																																																																																																																																																																																																			
	GND	550	551																																																																																																																																																																																																																																																																																																																																																																																																																																																																																																																																																																																																																																																																																																																																																																																																																																																																																																																																																																																																																																																																																																																																																																																																																																																																																																																																																																																																																																																																																																																																																																																																																			
	GND	552	553																																																																																																																																																																																																																																																																																																																																																																																																																																																																																																																																																																																																																																																																																																																																																																																																																																																																																																																																																																																																																																																																																																																																																																																																																																																																																																																																																																																																																																																																																																																																																																																																																			
	GND	554	555																																																																																																																																																																																																																																																																																																																																																																																																																																																																																																																																																																																																																																																																																																																																																																																																																																																																																																																																																																																																																																																																																																																																																																																																																																																																																																																																																																																																																																																																																																																																																																																																																			
	GND	556	557																																																																																																																																																																																																																																																																																																																																																																																																																																																																																																																																																																																																																																																																																																																																																																																																																																																																																																																																																																																																																																																																																																																																																																																																																																																																																																																																																																																																																																																																																																																																																																																																																			
	GND	558	559																																																																																																																																																																																																																																																																																																																																																																																																																																																																																																																																																																																																																																																																																																																																																																																																																																																																																																																																																																																																																																																																																																																																																																																																																																																																																																																																																																																																																																																																																																																																																																																																																			
	GND	560	561																																																																																																																																																																																																																																																																																																																																																																																																																																																																																																																																																																																																																																																																																																																																																																																																																																																																																																																																																																																																																																																																																																																																																																																																																																																																																																																																																																																																																																																																																																																																																																																																																			
	GND	562	563																																																																																																																																																																																																																																																																																																																																																																																																																																																																																																																																																																																																																																																																																																																																																																																																																																																																																																																																																																																																																																																																																																																																																																																																																																																																																																																																																																																																																																																																																																																																																																																																																			
	GND	564	565																																																																																																																																																																																																																																																																																																																																																																																																																																																																																																																																																																																																																																																																																																																																																																																																																																																																																																																																																																																																																																																																																																																																																																																																																																																																																																																																																																																																																																																																																																																																																																																																																			
	GND	566	567																																																																																																																																																																																																																																																																																																																																																																																																																																																																																																																																																																																																																																																																																																																																																																																																																																																																																																																																																																																																																																																																																																																																																																																																																																																																																																																																																																																																																																																																																																																																																																																																																			
	GND	568	569																																																																																																																																																																																																																																																																																																																																																																																																																																																																																																																																																																																																																																																																																																																																																																																																																																																																																																																																																																																																																																																																																																																																																																																																																																																																																																																																																																																																																																																																																																																																																																																																																			
	GND	570	571																																																																																																																																																																																																																																																																																																																																																																																																																																																																																																																																																																																																																																																																																																																																																																																																																																																																																																																																																																																																																																																																																																																																																																																																																																																																																																																																																																																																																																																																																																																																																																																																																			
	GND	572	573																																																																																																																																																																																																																																																																																																																																																																																																																																																																																																																																																																																																																																																																																																																																																																																																																																																																																																																																																																																																																																																																																																																																																																																																																																																																																																																																																																																																																																																																																																																																																																																																																			
	GND	574	575																																																																																																																																																																																																																																																																																																																																																																																																																																																																																																																																																																																																																																																																																																																																																																																																																																																																																																																																																																																																																																																																																																																																																																																																																																																																																																																																																																																																																																																																																																																																																																																																																			
	GND	576	577																																																																																																																																																																																																																																																																																																																																																																																																																																																																																																																																																																																																																																																																																																																																																																																																																																																																																																																																																																																																																																																																																																																																																																																																																																																																																																																																																																																																																																																																																																																																																																																																																			
	GND	578	579																																																																																																																																																																																																																																																																																																																																																																																																																																																																																																																																																																																																																																																																																																																																																																																																																																																																																																																																																																																																																																																																																																																																																																																																																																																																																																																																																																																																																																																																																																																																																																																																																			
	GND	580	581																																																																																																																																																																																																																																																																																																																																																																																																																																																																																																																																																																																																																																																																																																																																																																																																																																																																																																																																																																																																																																																																																																																																																																																																																																																																																																																																																																																																																																																																																																																																																																																																																			
	GND	582	583																																																																																																																																																																																																																																																																																																																																																																																																																																																																																																																																																																																																																																																																																																																																																																																																																																																																																																																																																																																																																																																																																																																																																																																																																																																																																																																																																																																																																																																																																																																																																																																																																			
	GND	584	585																																																																																																																																																																																																																																																																																																																																																																																																																																																																																																																																																																																																																																																																																																																																																																																																																																																																																																																																																																																																																																																																																																																																																																																																																																																																																																																																																																																																																																																																																																																																																																																																																			
	GND	586	587																																																																																																																																																																																																																																																																																																																																																																																																																																																																																																																																																																																																																																																																																																																																																																																																																																																																																																																																																																																																																																																																																																																																																																																																																																																																																																																																																																																																																																																																																																																																																																																																																			
	GND	588	589																																																																																																																																																																																																																																																																																																																																																																																																																																																																																																																																																																																																																																																																																																																																																																																																																																																																																																																																																																																																																																																																																																																																																																																																																																																																																																																																																																																																																																																																																																																																																																																																																			
	GND	590	591																																																																																																																																																																																																																																																																																																																																																																																																																																																																																																																																																																																																																																																																																																																																																																																																																																																																																																																																																																																																																																																																																																																																																																																																																																																																																																																																																																																																																																																																																																																																																																																																																			
	GND	592	593																																																																																																																																																																																																																																																																																																																																																																																																																																																																																																																																																																																																																																																																																																																																																																																																																																																																																																																																																																																																																																																																																																																																																																																																																																																																																																																																																																																																																																																																																																																																																																																																																			
	GND	594	595																																																																																																																																																																																																																																																																																																																																																																																																																																																																																																																																																																																																																																																																																																																																																																																																																																																																																																																																																																																																																																																																																																																																																																																																																																																																																																																																																																																																																																																																																																																																																																																																																			
	GND	596	597																																																																																																																																																																																																																																																																																																																																																																																																																																																																																																																																																																																																																																																																																																																																																																																																																																																																																																																																																																																																																																																																																																																																																																																																																																																																																																																																																																																																																																																																																																																																																																																																																			
	GND	598	599																																																																																																																																																																																																																																																																																																																																																																																																																																																																																																																																																																																																																																																																																																																																																																																																																																																																																																																																																																																																																																																																																																																																																																																																																																																																																																																																																																																																																																																																																																																																																																																																																			
	GND	600	601																																																																																																																																																																																																																																																																																																																																																																																																																																																																																																																																																																																																																																																																																																																																																																																																																																																																																																																																																																																																																																																																																																																																																																																																																																																																																																																																																																																																																																																																																																																																																																																																																			
	GND	602	603																																																																																																																																																																																																																																																																																																																																																																																																																																																																																																																																																																																																																																																																																																																																																																																																																																																																																																																																																																																																																																																																																																																																																																																																																																																																																																																																																																																																																																																																																																																																																																																																																			
	GND	604	605																																																																																																																																																																																																																																																																																																																																																																																																																																																																																																																																																																																																																																																																																																																																																																																																																																																																																																																																																																																																																																																																																																																																																																																																																																																																																																																																																																																																																																																																																																																																																																																																																			
	GND	606	607																																																																																																																																																																																																																																																																																																																																																																																																																																																																																																																																																																																																																																																																																																																																																																																																																																																																																																																																																																																																																																																																																																																																																																																																																																																																																																																																																																																																																																																																																																																																																																																																																			
	GND	608	609																																																																																																																																																																																																																																																																																																																																																																																																																																																																																																																																																																																																																																																																																																																																																																																																																																																																																																																																																																																																																																																																																																																																																																																																																																																																																																																																																																																																																																																																																																																																																																																																																			
	GND	610	611																																																																																																																																																																																																																																																																																																																																																																																																																																																																																																																																																																																																																																																																																																																																																																																																																																																																																																																																																																																																																																																																																																																																																																																																																																																																																																																																																																																																																																																																																																																																																																																																																			
	GND	612	613																																																																																																																																																																																																																																																																																																																																																																																																																																																																																																																																																																																																																																																																																																																																																																																																																																																																																																																																																																																																																																																																																																																																																																																																																																																																																																																																																																																																																																																																																																																																																																																																																			
	GND	614	615																																																																																																																																																																																																																																																																																																																																																																																																																																																																																																																																																																																																																																																																																																																																																																																																																																																																																																																																																																																																																																																																																																																																																																																																																																																																																																																																																																																																																																																																																																																																																																																																																			
	GND	616	617																																																																																																																																																																																																																																																																																																																																																																																																																																																																																																																																																																																																																																																																																																																																																																																																																																																																																																																																																																																																																																																																																																																																																																																																																																																																																																																																																																																																																																																																																																																																																																																																																			
	GND	618	619																																																																																																																																																																																																																																																																																																																																																																																																																																																																																																																																																																																																																																																																																																																																																																																																																																																																																																																																																																																																																																																																																																																																																																																																																																																																																																																																																																																																																																																																																																																																																																																																																			
	GND	620	621																																																																																																																																																																																																																																																																																																																																																																																																																																																																																																																																																																																																																																																																																																																																																																																																																																																																																																																																																																																																																																																																																																																																																																																																																																																																																																																																																																																																																																																																																																																																																																																																																			
	GND	622	623																																																																																																																																																																																																																																																																																																																																																																																																																																																																																																																																																																																																																																																																																																																																																																																																																																																																																																																																																																																																																																																																																																																																																																																																																																																																																																																																																																																																																																																																																																																																																																																																																			
	GND	624	625																																																																																																																																																																																																																																																																																																																																																																																																																																																																																																																																																																																																																																																																																																																																																																																																																																																																																																																																																																																																																																																																																																																																																																																																																																																																																																																																																																																																																																																																																																																																																																																																																			
	GND	626	627																																																																																																																																																																																																																																																																																																																																																																																																																																																																																																																																																																																																																																																																																																																																																																																																																																																																																																																																																																																																																																																																																																																																																																																																																																																																																																																																																																																																																																																																																																																																																																																																																			
	GND	628	629																																																																																																																																																																																																																																																																																																																																																																																																																																																																																																																																																																																																																																																																																																																																																																																																																																																																																																																																																																																																																																																																																																																																																																																																																																																																																																																																																																																																																																																																																																																																																																																																																			
	GND	630	631																																																																																																																																																																																																																																																																																																																																																																																																																																																																																																																																																																																																																																																																																																																																																																																																																																																																																																																																																																																																																																																																																																																																																																																																																																																																																																																																																																																																																																																																																																																																																																																																																			
	GND	632	633																																																																																																																																																																																																																																																																																																																																																																																																																																																																																																																																																																																																																																																																																																																																																																																																																																																																																																																																																																																																																																																																																																																																																																																																																																																																																																																																																																																																																																																																																																																																																																																																																			
	GND	634	635																																																																																																																																																																																																																																																																																																																																																																																																																																																																																																																																																																																																																																																																																																																																																																																																																																																																																																																																																																																																																																																																																																																																																																																																																																																																																																																																																																																																																																																																																																																																																																																																																			
	GND	636	637																																																																																																																																																																																																																																																																																																																																																																																																																																																																																																																																																																																																																																																																																																																																																																																																																																																																																																																																																																																																																																																																																																																																																																																																																																																																																																																																																																																																																																																																																																																																																																																																																			
	GND	638	639																																																																																																																																																																																																																																																																																																																																																																																																																																																																																																																																																																																																																																																																																																																																																																																																																																																																																																																																																																																																																																																																																																																																																																																																																																																																																																																																																																																																																																																																																																																																																																																																																			
	GND	640	641																																																																																																																																																																																																																																																																																																																																																																																																																																																																																																																																																																																																																																																																																																																																																																																																																																																																																																																																																																																																																																																																																																																																																																																																																																																																																																																																																																																																																																																																																																																																																																																																																			
	GND	642	643																																																																																																																																																																																																																																																																																																																																																																																																																																																																																																																																																																																																																																																																																																																																																																																																																																																																																																																																																																																																																																																																																																																																																																																																																																																																																																																																																																																																																																																																																																																																																																																																																			
	GND	644	645																																																																																																																																																																																																																																																																																																																																																																																																																																																																																																																																																																																																																																																																																																																																																																																																																																																																																																																																																																																																																																																																																																																																																																																																																																																																																																																																																																																																																																																																																																																																																																																																																			
	GND	646	647																																																																																																																																																																																																																																																																																																																																																																																																																																																																																																																																																																																																																																																																																																																																																																																																																																																																																																																																																																																																																																																																																																																																																																																																																																																																																																																																																																																																																																																																																																																																																																																																																			
	GND	648	649																																																																																																																																																																																																																																																																																																																																																																																																																																																																																																																																																																																																																																																																																																																																																																																																																																																																																																																																																																																																																																																																																																																																																																																																																																																																																																																																																																																																																																																																																																																																																																																																																			
	GND	650	651																																																																																																																																																																																																																																																																																																																																																																																																																																																																																																																																																																																																																																																																																																																																																																																																																																																																																																																																																																																																																																																																																																																																																																																																																																																																																																																																																																																																																																																																																																																																																																																																																			
	GND	652	653																																																																																																																																																																																																																																																																																																																																																																																																																																																																																																																																																																																																																																																																																																																																																																																																																																																																																																																																																																																																																																																																																																																																																																																																																																																																																																																																																																																																																																																																																																																																																																																																																			
	GND	654	655																																																																																																																																																																																																																																																																																																																																																																																																																																																																																																																																																																																																																																																																																																																																																																																																																																																																																																																																																																																																																																																																																																																																																																																																																																																																																																																																																																																																																																																																																																																																																																																																																			
	GND	656	657																																																																																																																																																																																																																																																																																																																																																																																																																																																																																																																																																																																																																																																																																																																																																																																																																																																																																																																																																																																																																																																																																																																																																																																																																																																																																																																																																																																																																																																																																																																																																																																																																			
	GND	658	659																																																																																																																																																																																																																																																																																																																																																																																																																																																																																																																																																																																																																																																																																																																																																																																																																																																																																																																																																																																																																																																																																																																																																																																																																																																																																																																																																																																																																																																																																																																																																																																																																			
	GND	660	661																																																																																																																																																																																																																																																																																																																																																																																																																																																																																																																																																																																																																																																																																																																																																																																																																																																																																																																																																																																																																																																																																																																																																																																																																																																																																																																																																																																																																																																																																																																																																																																																																			
	GND	662	663																																																																																																																																																																																																																																																																																																																																																																																																																																																																																																																																																																																																																																																																																																																																																																																																																																																																																																																																																																																																																																																																																																																																																																																																																																																																																																																																																																																																																																																																																																																																																																																																																			
	GND	664	665																																																																																																																																																																																																																																																																																																																																																																																																																																																																																																																																																																																																																																																																																																																																																																																																																																																																																																																																																																																																																																																																																																																																																																																																																																																																																																																																																																																																																																																																																																																																																																																																																			
	GND	666	667																																																																																																																																																																																																																																																																																																																																																																																																																																																																																																																																																																																																																																																																																																																																																																																																																																																																																																																																																																																																																																																																																																																																																																																																																																																																																																																																																																																																																																																																																																																																																																																																																			
	GND	668	669																																																																																																																																																																																																																																																																																																																																																																																																																																																																																																																																																																																																																																																																																																																																																																																																																																																																																																																																																																																																																																																																																																																																																																																																																																																																																																																																																																																																																																																																																																																																																																																																																			
	GND	670	671																																																																																																																																																																																																																																																																																																																																																																																																																																																																																																																																																																																																																																																																																																																																																																																																																																																																																																																																																																																																																																																																																																																																																																																																																																																																																																																																																																																																																																																																																																																																																																																																																			
	GND	672	673																																																																																																																																																																																																																																																																																																																																																																																																																																																																																																																																																																																																																																																																																																																																																																																																																																																																																																																																																																																																																																																																																																																																																																																																																																																																																																																																																																																																																																																																																																																																																																																																																			
	GND	674	675																																																																																																																																																																																																																																																																																																																																																																																																																																																																																																																																																																																																																																																																																																																																																																																																																																																																																																																																																																																																																																																																																																																																																																																																																																																																																																																																																																																																																																																																																																																																																																																																																			
	GND	676	677																																																																																																																																																																																																																																																																																																																																																																																																																																																																																																																																																																																																																																																																																																																																																																																																																																																																																																																																																																																																																																																																																																																																																																																																																																																																																																																																																																																																																																																																																																																																																																																																																			
	GND	678	679																																																																																																																																																																																																																																																																																																																																																																																																																																																																																																																																																																																																																																																																																																																																																																																																																																																																																																																																																																																																																																																																																																																																																																																																																																																																																																																																																																																																																																																																																																																																																																																																																			
	GND	680	681																																																																																																																																																																																																																																																																																																																																																																																																																																																																																																																																																																																																																																																																																																																																																																																																																																																																																																																																																																																																																																																																																																																																																																																																																																																																																																																																																																																																																																																																																																																																																																																																																			
	GND	682	683																																																																																																																																																																																																																																																																																																																																																																																																																																																																																																																																																																																																																																																																																																																																																																																																																																																																																																																																																																																																																																																																																																																																																																																																																																																																																																																																																																																																																																																																																																																																																																																																																			
	GND	684	685																																																																																																																																																																																																																																																																																																																																																																																																																																																																																																																																																																																																																																																																																																																																																																																																																																																																																																																																																																																																																																																																																																																																																																																																																																																																																																																																																																																																																																																																																																																																																																																																																			
	GND	686	687																																																																																																																																																																																																																																																																																																																																																																																																																																																																																																																																																																																																																																																																																																																																																																																																																																																																																																																																																																																																																																																																																																																																																																																																																																																																																																																																																																																																																																																																																																																																																																																																																			
	GND	688	689																																																																																																																																																																																																																																																																																																																																																																																																																																																																																																																																																																																																																																																																																																																																																																																																																																																																																																																																																																																																																																																																																																																																																																																																																																																																																																																																																																																																																																																																																																																																																																																																																			
	GND	690	691																																																																																																																																																																																																																																																																																																																																																																																																																																																																																																																																																																																																																																																																																																																																																																																																																																																																																																																																																																																																																																																																																																																																																																																																																																																																																																																																																																																																																																																																																																																																																																																																																			
	GND	692	693																																																																																																																																																																																																																																																																																																																																																																																																																																																																																																																																																																																																																																																																																																																																																																																																																																																																																																																																																																																																																																																																																																																																																																																																																																																																																																																																																																																																																																																																																																																																																																																																																			
	GND	694	695																																																																																																																																																																																																																																																																																																																																																																																																																																																																																																																																																																																																																																																																																																																																																																																																																																																																																																																																																																																																																																																																																																																																																																																																																																																																																																																																																																																																																																																																																																																																																																																																																			
	GND	696	697																																																																																																																																																																																																																																																																																																																																																																																																																																																																																																																																																																																																																																																																																																																																																																																																																																																																																																																																																																																																																																																																																																																																																																																																																																																																																																																																																																																																																																																																																																																																																																																																																			
	GND	698	699																																																																																																																																																																																																																																																																																																																																																																																																																																																																																																																																																																																																																																																																																																																																																																																																																																																																																																																																																																																																																																																																																																																																																																																																																																																																																																																																																																																																																																																																																																																																																																																																																			
	GND	700	701																																																																																																																																																																																																																																																																																																																																																																																																																																																																																																																																																																																																																																																																																																																																																																																																																																																																																																																																																																																																																																																																																																																																																																																																																																																																																																																																																																																																																																																																																																																																																																																																																			
	GND	702	703																																																																																																																																																																																																																																																																																																																																																																																																																																																																																																																																																																																																																																																																																																																																																																																																																																																																																																																																																																																																																																																																																																																																																																																																																																																																																																																																																																																																																																																																																																																																																																																																																			
	GND	704	705																																																																																																																																																																																																																																																																																																																																																																																																																																																																																																																																																																																																																																																																																																																																																																																																																																																																																																																																																																																																																																																																																																																																																																																																																																																																																																																																																																																																																																																																																																																																																																																																																			
	GND	706	707																																																																																																																																																																																																																																																																																																																																																																																																																																																																																																																																																																																																																																																																																																																																																																																																																																																																																																																																																																																																																																																																																																																																																																																																																																																																																																																																																																																																																																																																																																																																																																																																																			
	GND	708	709																																																																																																																																																																																																																																																																																																																																																																																																																																																																																																																																																																																																																																																																																																																																																																																																																																																																																																																																																																																																																																																																																																																																																																																																																																																																																																																																																																																																																																																																																																																																																																																																																			
	GND	710	711																																																																																																																																																																																																																																																																																																																																																																																																																																																																																																																																																																																																																																																																																																																																																																																																																																																																																																																																																																																																																																																																																																																																																																																																																																																																																																																																																																																																																																																																																																																																																																																																																			
	GND	712	713																																																																																																																																																																																																																																																																																																																																																																																																																																																																																																																																																																																																																																																																																																																																																																																																																																																																																																																																																																																																																																																																																																																																																																																																																																																																																																																																																																																																																																																																																																																																																																																																																			
	GND	714	715																																																																																																																																																																																																																																																																																																																																																																																																																																																																																																																																																																																																																																																																																																																																																																																																																																																																																																																																																																																																																																																																																																																																																																																																																																																																																																																																																																																																																																																																																																																																																																																																																			
	GND	716	717																																																																																																																																																																																																																																																																																																																																																																																																																																																																																																																																																																																																																																																																																																																																																																																																																																																																																																																																																																																																																																																																																																																																																																																																																																																																																																																																																																																																																																																																																																																																																																																																																			
	GND	718	719																																																																																																																																																																																																																																																																																																																																																																																																																																																																																																																																																																																																																																																																																																																																																																																																																																																																																																																																																																																																																																																																																																																																																																																																																																																																																																																																																																																																																																																																																																																																																																																																																			
	GND	720	721																																																																																																																																																																																																																																																																																																																																																																																																																																																																																																																																																																																																																																																																																																																																																																																																																																																																																																																																																																																																																																																																																																																																																																																																																																																																																																																																																																																																																																																																																																																																																																																																																			
	GND	722	723																																																																																																																																																																																																																																																																																																																																																																																																																																																																																																																																																																																																																																																																																																																																																																																																																																																																																																																																																																																																																																																																																																																																																																																																																																																																																																																																																																																																																																																																																																																																																																																																																			
	GND	724	725																																																																																																																																																																																																																																																																																																																																																																																																																																																																																																																																																																																																																																																																																																																																																																																																																																																																																																																																																																																																																																																																																																																																																																																																																																																																																																																																																																																																																																																																																																																																																																																																																			
	GND	726	727																																																																																																																																																																																																																																																																																																																																																																																																																																																																																																																																																																																																																																																																																																																																																																																																																																																																																																																																																																																																																																																																																																																																																																																																																																																																																																																																																																																																																																																																																																																																																																																																																			
	GND	728	729																																																																																																																																																																																																																																																																																																																																																																																																																																																																																																																																																																																																																																																																																																																																																																																																																																																																																																																																																																																																																																																																																																																																																																																																																																																																																																																																																																																																																																																																																																																																																																																																																			
	GND	730	731																																																																																																																																																																																																																																																																																																																																																																																																																																																																																																																																																																																																																																																																																																																																																																																																																																																																																																																																																																																																																																																																																																																																																																																																																																																																																																																																																																																																																																																																																																																																																																																																																			
	GND	732	733																																																																																																																																																																																																																																																																																																																																																																																																																																																																																																																																																																																																																																																																																																																																																																																																																																																																																																																																																																																																																																																																																																																																																																																																																																																																																																																																																																																																																																																																																																																																																																																																																			
	GND	734	735																																																																																																																																																																																																																																																																																																																																																																																																																																																																																																																																																																																																																																																																																																																																																																																																																																																																																																																																																																																																																																																																																																																																																																																																																																																																																																																																																																																																																																																																																																																																																																																																																			
	GND	736	737																																																																																																																																																																																																																																																																																																																																																																																																																																																																																																																																																																																																																																																																																																																																																																																																																																																																																																																																																																																																																																																																																																																																																																																																																																																																																																																																																																																																																																																																																																																																																																																																																			
	GND	738	739																																																																																																																																																																																																																																																																																																																																																																																																																																																																																																																																																																																																																																																																																																																																																																																																																																																																																																																																																																																																																																																																																																																																																																																																																																																																																																																																																																																																																																																																																																																																																																																																																			
	GND	740	741																																																																																																																																																																																																																																																																																																																																																																																																																																																																																																																																																																																																																																																																																																																																																																																																																																																																																																																																																																																																																																																																																																																																																																																																																																																																																																																																																																																																																																																																																																																																																																																																																			
	GND	742	743																																																																																																																																																																																																																																																																																																																																																																																																																																																																																																																																																																																																																																																																																																																																																																																																																																																																																																																																																																																																																																																																																																																																																																																																																																																																																																																																																																																																																																																																																																																																																																																																																			
	GND	744	745																																																																																																																																																																																																																																																																																																																																																																																																																																																																																																																																																																																																																																																																																																																																																																																																																																																																																																																																																																																																																																																																																																																																																																																																																																																																																																																																																																																																																																																																																																																																																																																																																			
	GND	746	747																																																																																																																																																																																																																																																																																																																																																																																																																																																																																																																																																																																																																																																																																																																																																																																																																																																																																																																																																																																																																																																																																																																																																																																																																																																																																																																																																																																																																																																																																																																																																																																																																			
	GND	748	749																																																																																																																																																																																																																																																																																																																																																																																																																																																																																																																																																																																																																																																																																																																																																																																																																																																																																																																																																																																																																																																																																																																																																																																																																																																																																																																																																																																																																																																																																																																																																																																																																			
	GND	750	751																																																																																																																																																																																																																																																																																																																																																																																																																																																																																																																																																																																																																																																																																																																																																																																																																																																																																																																																																																																																																																																																																																																																																																																																																																																																																																																																																																																																																																																																																																																																																																																																																			
	GND	752	753																																																																																																																																																																																																																																																																																																																																																																																																																																																																																																																																																																																																																																																																																																																																																																																																																																																																																																																																																																																																																																																																																																																																																																																																																																																																																																																																																																																																																																																																																																																																																																																																																			
	GND	754	755																																																																																																																																																																																																																																																																																																																																																																																																																																																																																																																																																																																																																																																																																																																																																																																																																																																																																																																																																																																																																																																																																																																																																																																																																																																																																																																																																																																																																																																																																																																																																																																																																			
	GND	756	757																																																																																																																																																																																																																																																																																																																																																																																																																																																																																																																																																																																																																																																																																																																																																																																																																																																																																																																																																																																																																																																																																																																																																																																																																																																																																																																																																																																																																																																																																																																																																																																																																			
	GND	758	759																																																																																																																																																																																																																																																																																																																																																																																																																																																																																																																																																																																																																																																																																																																																																																																																																																																																																																																																																																																																																																																																																																																																																																																																																																																																																																																																																																																																																																																																																																																																																																																																																			
	GND	760	761																																																																																																																																																																																																																																																																																																																																																																																																																																																																																																																																																																																																																																																																																																																																																																																																																																																																																																																																																																																																																																																																																																																																																																																																																																																																																																																																																																																																																																																																																																																																																																																																																			
	GND	762	763																																																																																																																																																																																																																																																																																																																																																																																																																																																																																																																																																																																																																																																																																																																																																																																																																																																																																																																																																																																																																																																																																																																																																																																																																																																																																																																																																																																																																																																																																																																																																																																																																			
	GND	764	765																																																																																																																																																																																																																																																																																																																																																																																																																																																																																																																																																																																																																																																																																																																																																																																																																																																																																																																																																																																																																																																																																																																																																																																																																																																																																																																																																																																																																																																																																																																																																																																																																			
	GND	766	767																																																																																																																																																																																																																																																																																																																																																																																																																																																																																																																																																																																																																																																																																																																																																																																																																																																																																																																																																																																																																																																																																																																																																																																																																																																																																																																																																																																																																																																																																																																																																																																																																			
	GND	768	769																																																																																																																																																																																																																																																																																																																																																																																																																																																																																																																																																																																																																																																																																																																																																																																																																																																																																																																																																																																																																																																																																																																																																																																																																																																																																																																																																																																																																																																																																																																																																																																																																			
	GND	770	771																																																																																																																																																																																																																																																																																																																																																																																																																																																																																																																																																																																																																																																																																																																																																																																																																																																																																																																																																																																																																																																																																																																																																																																																																																																																																																																																																																																																																																																																																																																																																																																																																			
	GND	772	773																																																																																																																																																																																																																																																																																																																																																																																																																																																																																																																																																																																																																																																																																																																																																																																																																																																																																																																																																																																																																																																																																																																																																																																																																																																																																																																																																																																																																																																																																																																																																																																																																			
	GND	774	775																																																																																																																																																																																																																																																																																																																																																																																																																																																																																																																																																																																																																																																																																																																																																																																																																																																																																																																																																																																																																																																																																																																																																																																																																																																																																																																																																																																																																																																																																																																																																																																																																			
	GND	776	777																																																																																																																																																																																																																																																																																																																																																																																																																																																																																																																																																																																																																																																																																																																																																																																																																																																																																																																																																																																																																																																																																																																																																																																																																																																																																																																																																																																																																																																																																																																																																																																																																			
	GND	778	779																																																																																																																																																																																																																																																																																																																																																																																																																																																																																																																																																																																																																																																																																																																																																																																																																																																																																																																																																																																																																																																																																																																																																																																																																																																																																																																																																																																																																																																																																																																																																																																																																			
	GND	780	781																																																																																																																																																																																																																																																																																																																																																																																																																																																																																																																																																																																																																																																																																																																																																																																																																																																																																																																																																																																																																																																																																																																																																																																																																																																																																																																																																																																																																																																																																																																																																																																																																			
	GND	782	783																																																																																																																																																																																																																																																																																																																																																																																																																																																																																																																																																																																																																																																																																																																																																																																																																																																																																																																																																																																																																																																																																																																																																																																																																																																																																																																																																																																																																																																																																																																																																																																																																			
	GND	784	785																																																																																																																																																																																																																																																																																																																																																																																																																																																																																																																																																																																																																																																																																																																																																																																																																																																																																																																																																																																																																																																																																																																																																																																																																																																																																																																																																																																																																																																																																																																																																																																																																			
	GND	786	787																																																																																																																																																																																																																																																																																																																																																																																																																																																																																																																																																																																																																																																																																																																																																																																																																																																																																																																																																																																																																																																																																																																																																																																																																																																																																																																																																																																																																																																																																																																																																																																																																			
	GND	788	789																																																																																																																																																																																																																																																																																																																																																																																																																																																																																																																																																																																																																																																																																																																																																																																																																																																																																																																																																																																																																																																																																																																																																																																																																																																																																																																																																																																																																																																																																																																																																																																																																			
	GND	790	791																																																																																																																																																																																																																																																																																																																																																																																																																																																																																																																																																																																																																																																																																																																																																																																																																																																																																																																																																																																																																																																																																																																																																																																																																																																																																																																																																																																																																																																																																																																																																																																																																			
	GND	792	793																																																																																																																																																																																																																																																																																																																																																																																																																																																																																																																																																																																																																																																																																																																																																																																																																																																																																																																																																																																																																																																																																																																																																																																																																																																																																																																																																																																																																																																																																																																																																																																																																			
	GND	794	795																																																																																																																																																																																																																																																																																																																																																																																																																																																																																																																																																																																																																																																																																																																																																																																																																																																																																																																																																																																																																																																																																																																																																																																																																																																																																																																																																																																																																																																																																																																																																																																																																			
	GND	796	797																																																																																																																																																																																																																																																																																																																																																																																																																																																																																																																																																																																																																																																																																																																																																																																																																																																																																																																																																																																																																																																																																																																																																																																																																																																																																																																																																																																																																																																																																																																																																																																																																			
	GND	798	799																																																																																																																																																																																																																																																																																																																																																																																																																																																																																																																																																																																																																																																																																																																																																																																																																																																																																																																																																																																																																																																																																																																																																																																																																																																																																																																																																																																																																																																																																																																																																																																																																			
	GND	800	801																																																																																																																																																																																																																																																																																																																																																																																																																																																																																																																																																																																																																																																																																																																																																																																																																																																																																																																																																																																																																																																																																																																																																																																																																																																																																																																																																																																																																																																																																																																																																																																																																			
	GND	802	803																																																																																																																																																																																																																																																																																																																																																																																																																																																																																																																																																																																																																																																																																																																																																																																																																																																																																																																																																																																																																																																																																																																																																																																																																																																																																																																																																																																																																																																																																																																																																																																																																			
	GND	804	805																																																																																																																																																																																																																																																																																																																																																																																																																																																																																																																																																																																																																																																																																																																																																																																																																																																																																																																																																																																																																																																																																																																																																																																																																																																																																																																																																																																																																																																																																																																																																																																																																			
	GND	806	807																																																																																																																																																																																																																																																																																																																																																																																																																																																																																																																																																																																																																																																																																																																																																																																																																																																																																																																																																																																																																																																																																																																																																																																																																																																																																																																																																																																																																																																																																																																																																																																																																			
	GND	808	809																																																																																																																																																																																																																																																																																																																																																																																																																																																																																																																																																																																																																																																																																																																																																																																																																																																																																																																																																																																																																																																																																																																																																																																																																																																																																																																																																																																																																																																																																																																																																																																																																			
	GND	810	811																																																																																																																																																																																																																																																																																																																																																																																																																																																																																																																																																																																																																																																																																																																																																																																																																																																																																																																																																																																																																																																																																																																																																																																																																																																																																																																																																																																																																																																																																																																																																																																																																			
	GND	812	813																																																																																																																																																																																																																																																																																																																																																																																																																																																																																																																																																																																																																																																																																																																																																																																																																																																																																																																																																																																																																																																																																																																																																																																																																																																																																																																																																																																																																																																																																																																																																																																																																			
	GND	814	815																																																																																																																																																																																																																																																																																																																																																																																																																																																																																																																																																																																																																																																																																																																																																																																																																																																																																																																																																																																																																																																																																																																																																																																																																																																																																																																																																																																																																																																																																																																																																																																																																			
	GND	816	817																																																																																																																																																																																																																																																																																																																																																																																																																																																																																																																																																																																																																																																																																																																																																																																																																																																																																																																																																																																																																																																																																																																																																																																																																																																																																																																																																																																																																																																																																																																																																																																																																			
	GND	818	819																																																																																																																																																																																																																																																																																																																																																																																																																																																																																																																																																																																																																																																																																																																																																																																																																																																																																																																																																																																																																																																																																																																																																																																																																																																																																																																																																																																																																																																																																																																																																																																																																			
	GND	820	821																																																																																																																																																																																																																																																																																																																																																																																																																																																																																																																																																																																																																																																																																																																																																																																																																																																																																																																																																																																																																																																																																																																																																																																																																																																																																																																																																																																																																																																																																																																																																																																																																			
	GND	822	823																																																																																																																																																																																																																																																																																																																																																																																																																																																																																																																																																																																																																																																																																																																																																																																																																																																																																																																																																																																																																																																																																																																																																																																																																																																																																																																																																																																																																																																																																																																																																																																																																			
	GND	824	825																																																																																																																																																																																																																																																																																																																																																																																																																																																																																																																																																																																																																																																																																																																																																																																																																																																																																																																																																																																																																																																																																																																																																																																																																																																																																																																																																																																																																																																																																																																																																																																																																			
	GND	826	827																																																																																																																																																																																																																																																																																																																																																																																																																																																																																																																																																																																																																																																																																																																																																																																																																																																																																																																																																																																																																																																																																																																																																																																																																																																																																																																																																																																																																																																																																																																																																																																																																			
	GND	828	829																																																																																																																																																																																																																																																																																																																																																																																																																																																																																																																																																																																																																																																																																																																																																																																																																																																																																																																																																																																																																																																																																																																																																																																																																																																																																																																																																																																																																																																																																																																																																																																																																			
	GND	830	831																																																																																																																																																																																																																																																																																																																																																																																																																																																																																																																																																																																																																																																																																																																																																																																																																																																																																																																																																																																																																																																																																																																																																																																																																																																																																																																																																																																																																																																																																																																																																																																																																			
	GND	832	833																																																																																																																																																																																																																																																																																																																																																																																																																																																																																																																																																																																																																																																																																																																																																																																																																																																																																																																																																																																																																																																																																																																																																																																																																																																																																																																																																																																																																																																																																																																																																																																																																			
	GND	834	835																																																																																																																																																																																																																																																																																																																																																																																																																																																																																																																																																																																																																																																																																																																																																																																																																																																																																																																																																																																																																																																																																																																																																																																																																																																																																																																																																																																																																																																																																																																																																																																																																			
	GND	836	837																																																																																																																																																																																																																																																																																																																																																																																																																																																																																																																																																																																																																																																																																																																																																																																																																																																																																																																																																																																																																																																																																																																																																																																																																																																																																																																																																																																																																																																																																																																																																																																																																			
	GND	838	839																																																																																																																																																																																																																																																																																																																																																																																																																																																																																																																																																																																																																																																																																																																																																																																																																																																																																																																																																																																																																																																																																																																																																																																																																																																																																																																																																																																																																																																																																																																																																																																																																			
	GND	840	841																																																																																																																																																																																																																																																																																																																																																																																																																																																																																																																																																																																																																																																																																																																																																																																																																																																																																																																																																																																																																																																																																																																																																																																																																																																																																																																																																																																																																																																																																																																																																																																																																			
	GND	842	843																																																																																																																																																																																																																																																																																																																																																																																																																																																																																																																																																																																																																																																																																																																																																																																																																																																																																																																																																																																																																																																																																																																																																																																																																																																																																																																																																																																																																																																																																																																																																																																																																			
	GND	844	845																																																																																																																																																																																																																																																																																																																																																																																																																																																																																																																																																																																																																																																																																																																																																																																																																																																																																																																																																																																																																																																																																																																																																																																																																																																																																																																																																																																																																																																																																																																																																																																																																			
	GND	846	847																																																																																																																																																																																																																																																																																																																																																																																																																																																																																																																																																																																																																																																																																																																																																																																																																																																																																																																																																																																																																																																																																																																																																																																																																																																																																																																																																																																																																																																																																																																																																																																																																			
	GND	848	849																																																																																																																																																																																																																																																																																																																																																																																																																																																																																																																																																																																																																																																																																																																																																																																																																																																																																																																																																																																																																																																																																																																																																																																																																																																																																																																																																																																																																																																																																																																																																																																																																			
	GND	850	851																																																																																																																																																																																																																																																																																																																																																																																																																																																																																																																																																																																																																																																																																																																																																																																																																																																																																																																																																																																																																																																																																																																																																																																																																																																																																																																																																																																																																																																																																																																																																																																																																			
	GND	852	853																																																																																																																																																																																																																																																																																																																																																																																																																																																																																																																																																																																																																																																																																																																																																																																																																																																																																																																																																																																																																																																																																																																																																																																																																																																																																																																																																																																																																																																																																																																																																																																																																			
	GND	854	855																																																																																																																																																																																																																																																																																																																																																																																																																																																																																																																																																																																																																																																																																																																																																																																																																																																																																																																																																																																																																																																																																																																																																																																																																																																																																																																																																																																																																																																																																																																																																																																																																			
	GND	856	857																																																																																																																																																																																																																																																																																																																																																																																																																																																																																																																																																																																																																																																																																																																																																																																																																																																																																																																																																																																																																																																																																																																																																																																																																																																																																																																																																																																																																																																																																																																																																																																																																			
	GND	858	859																																																																																																																																																																																																																																																																																																																																																																																																																																																																																																																																																																																																																																																																																																																																																																																																																																																																																																																																																																																																																																																																																																																																																																																																																																																																																																																																																																																																																																																																																																																																																																																																																			
	GND																																																																																																																																																																																																																																																																																																																																																																																																																																																																																																																																																																																																																																																																																																																																																																																																																																																																																																																																																																																																																																																																																																																																																																																																																																																																																																																																																																																																																																																																																																																																																																																																																					

BATTERY CONNECTOR

电池连接器

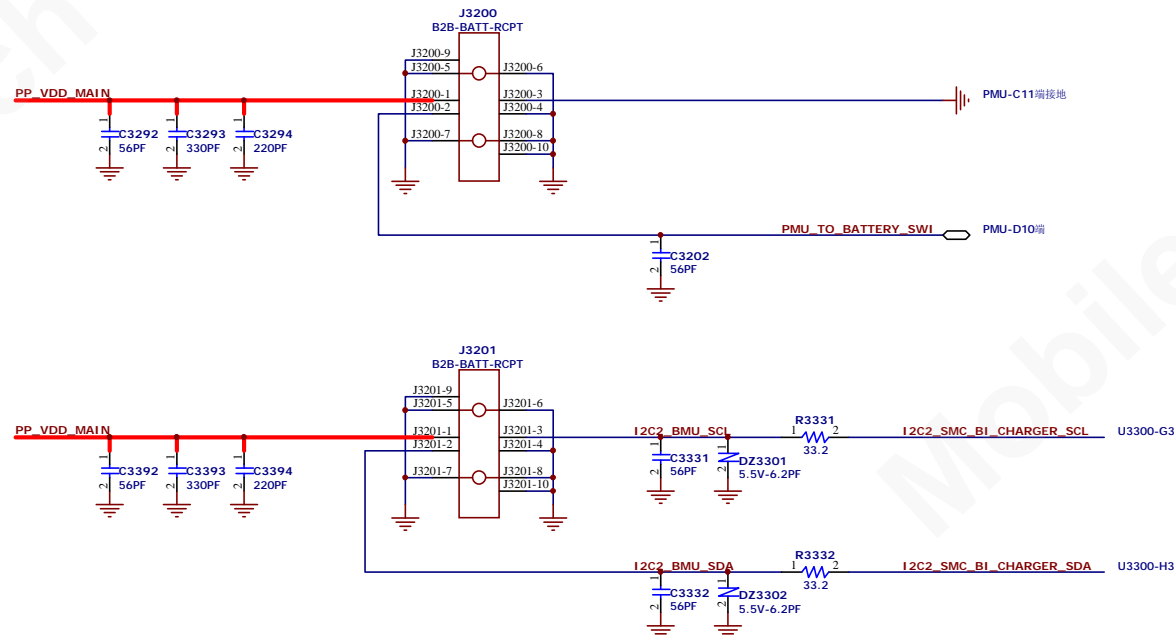

Cyclone + Button Connector 按键连接器

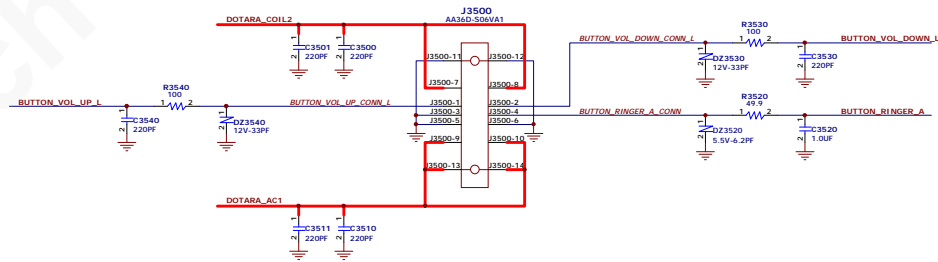

Wide Camera Connector 广角相机连接器

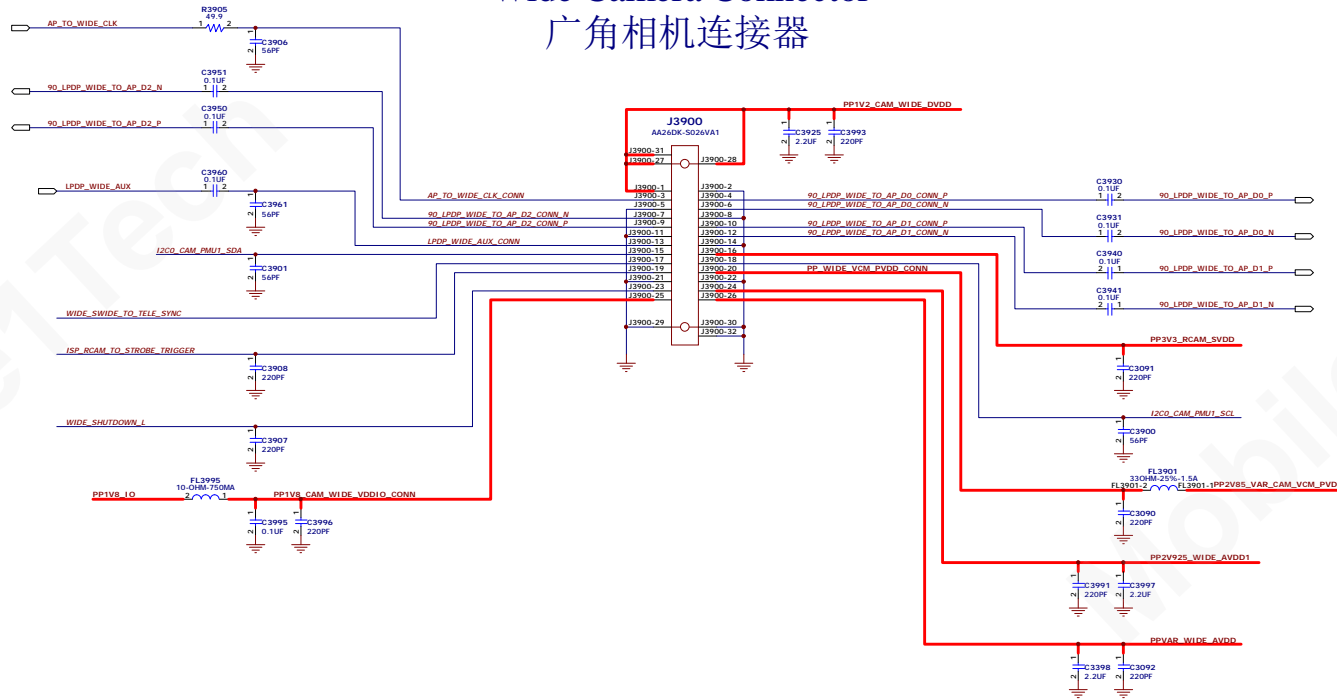

SWide Camera Connector 超广角相机连接器

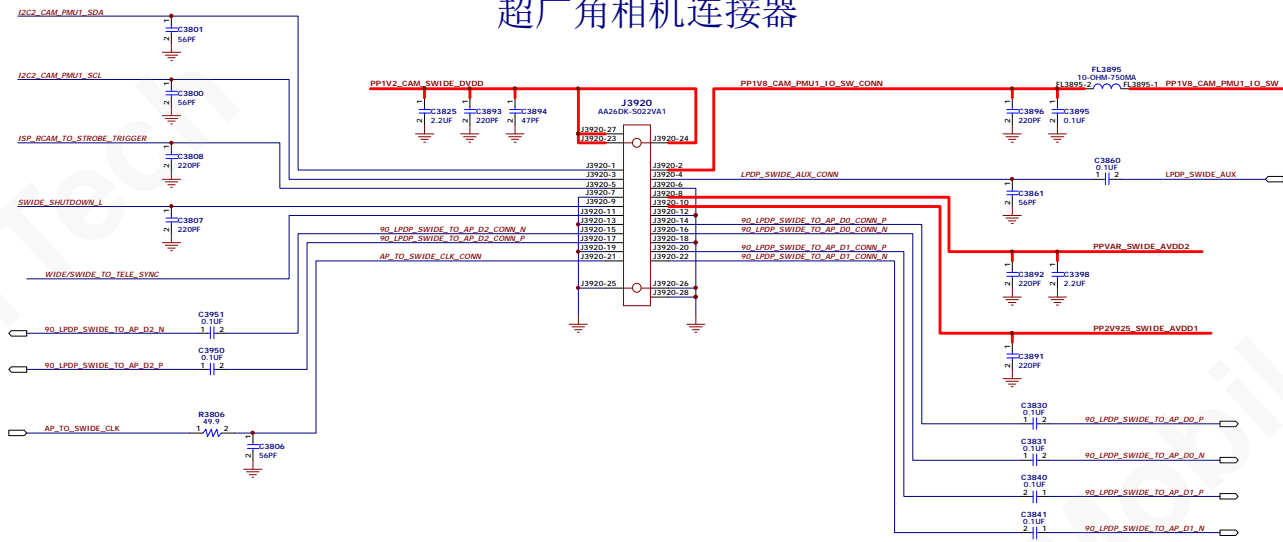

Tele Cam Connector 长焦相机连接器

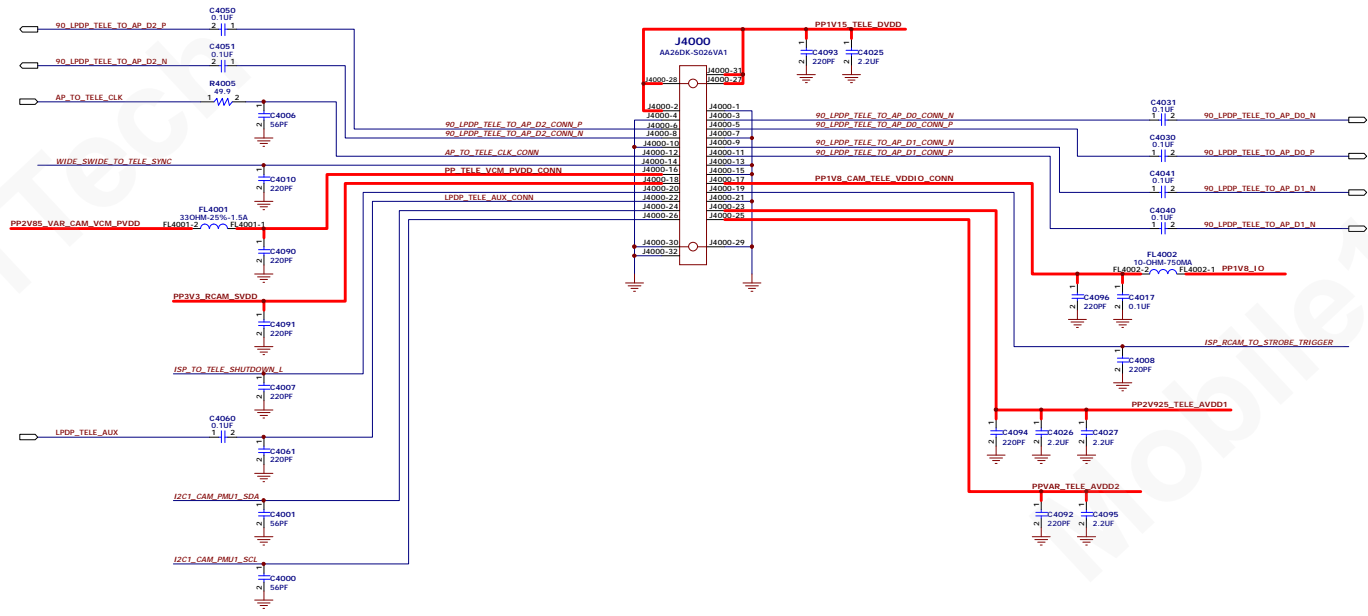

FCAM Connector 前置相机连接器

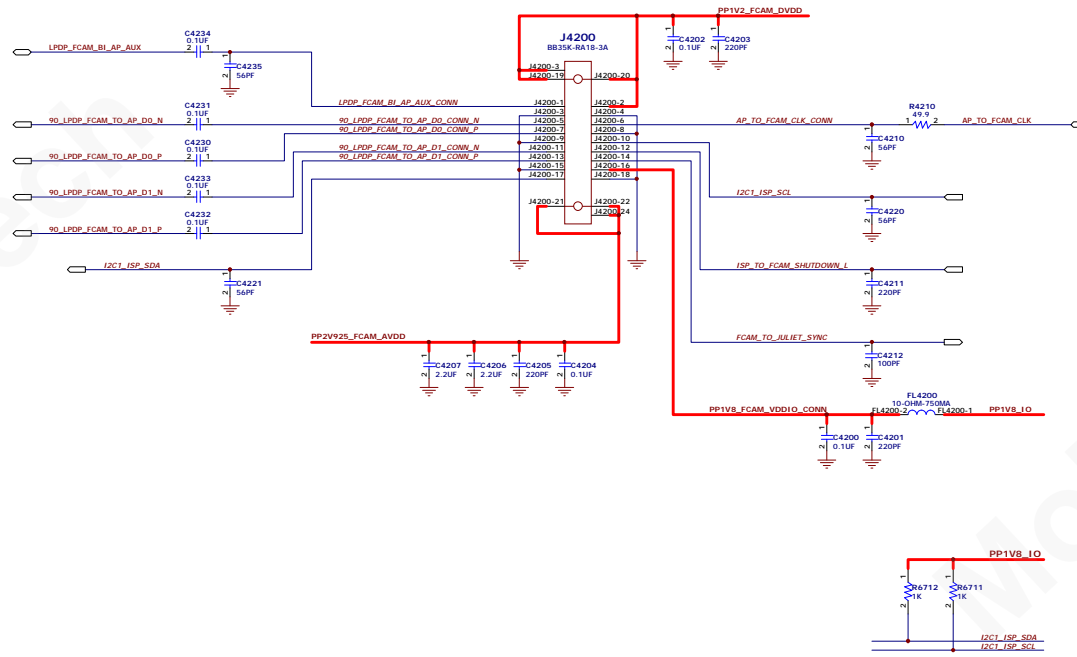

Strobe + Button Connector 闪光灯及开机键连接器

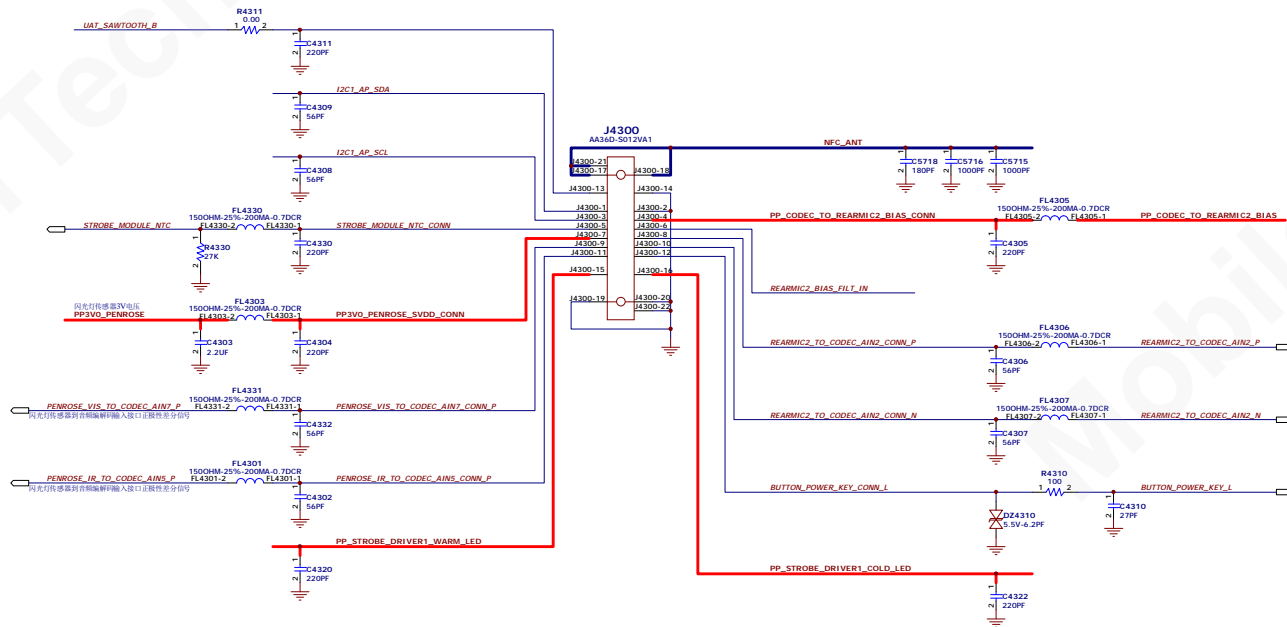

PEARL: B2B Romeo + Juliet
Romeo Connector
点阵投射连接器

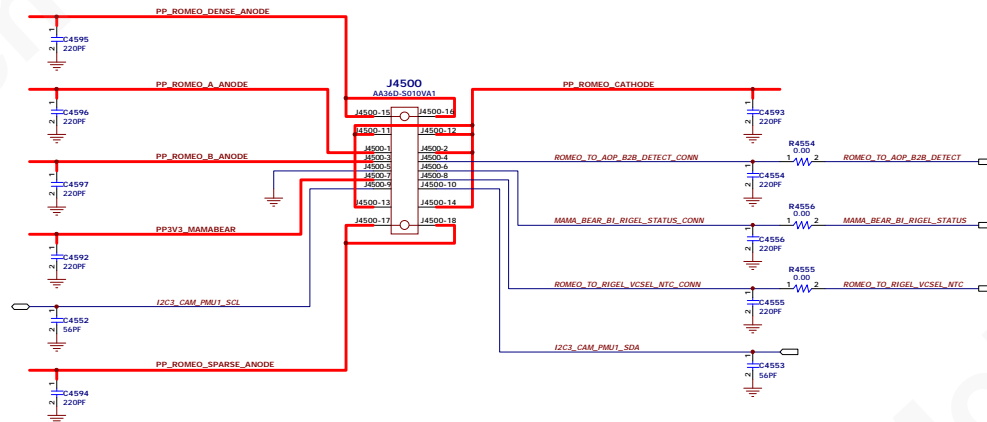

IRCAM Connector

PEARL: B2B Juliet

面容红外相机连接器

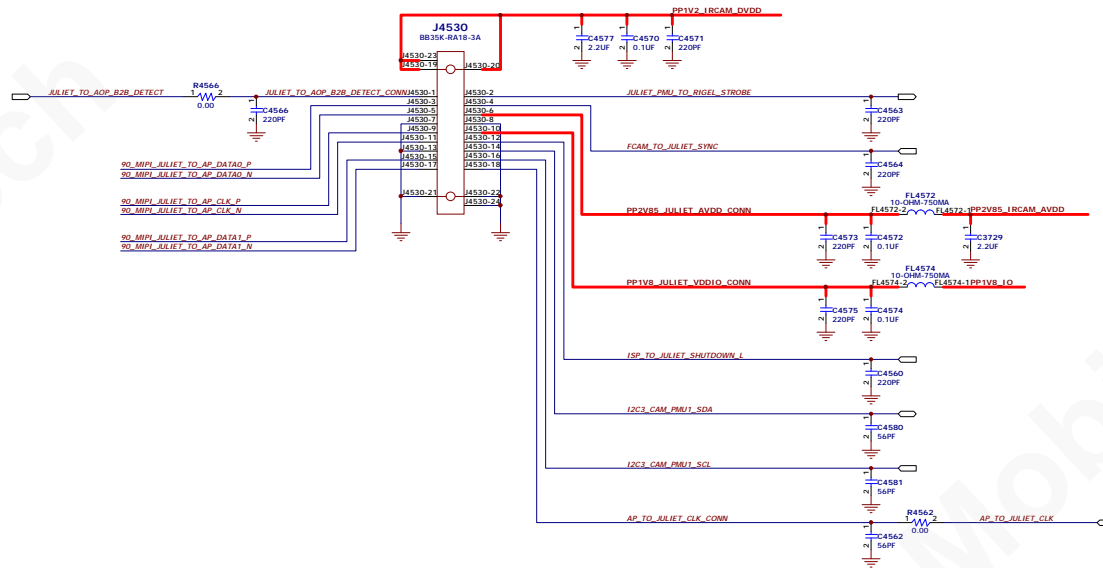

Rosaline + Sensor Connector

泛光照射器和传感器的连接器

PEARL: B2B Rosaline + Sensor

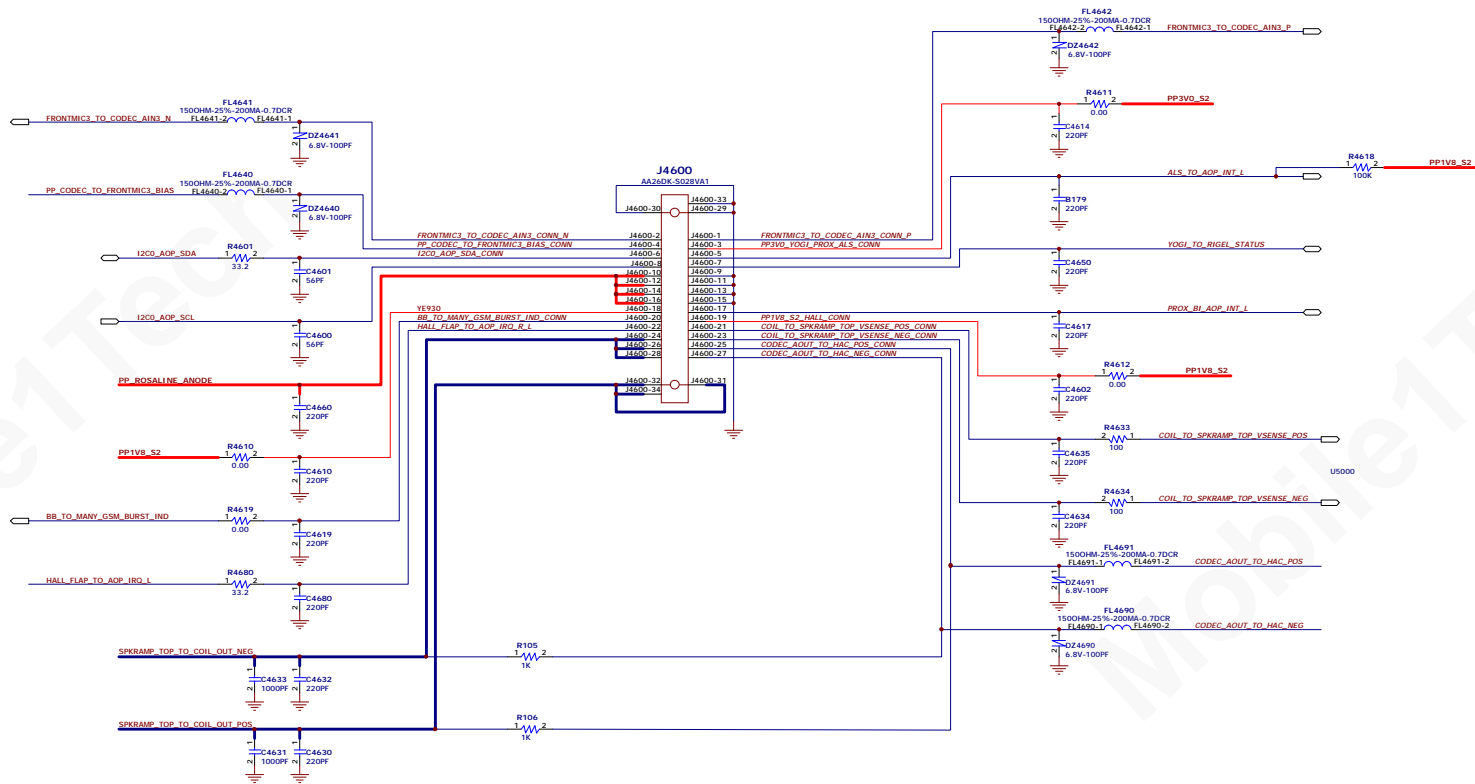

Display Flex Connector 显示屏连接器

CG: B2B Display

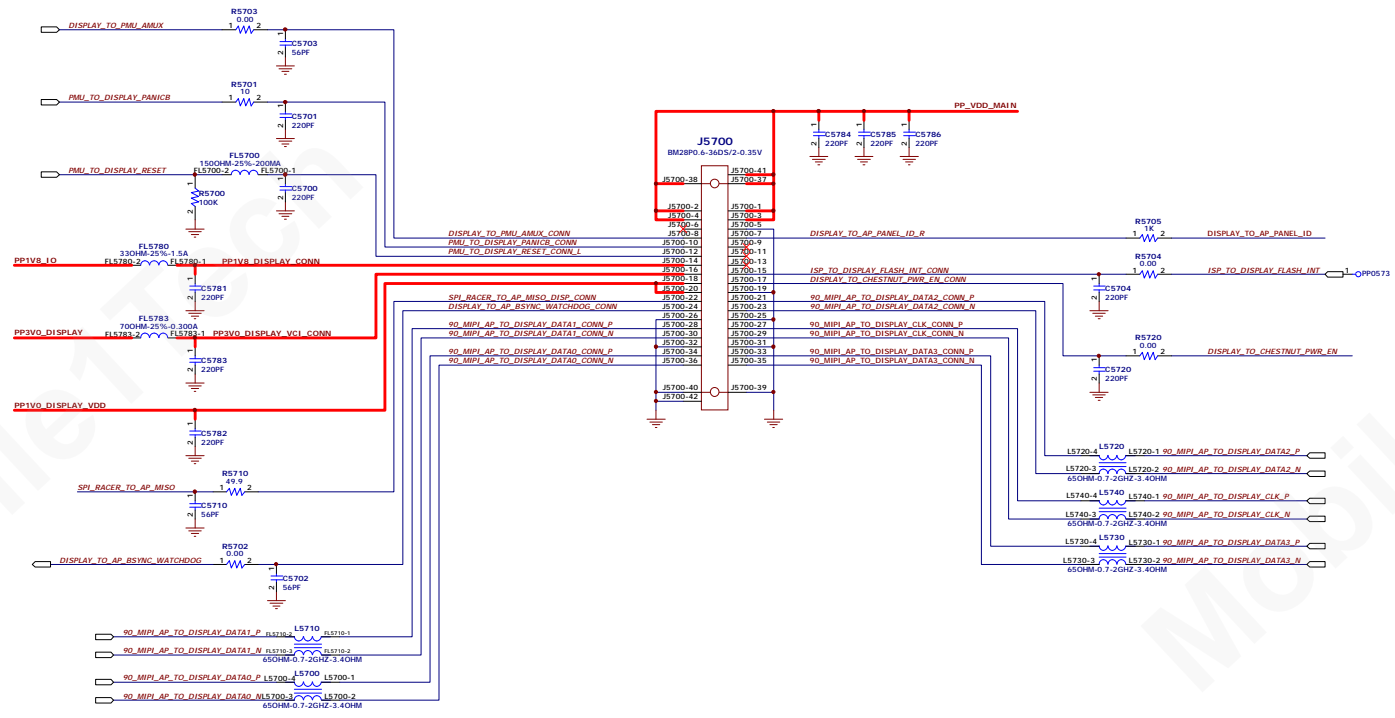

Luna + Touch Connector

CG: B2B Luna & Touch
触控单元

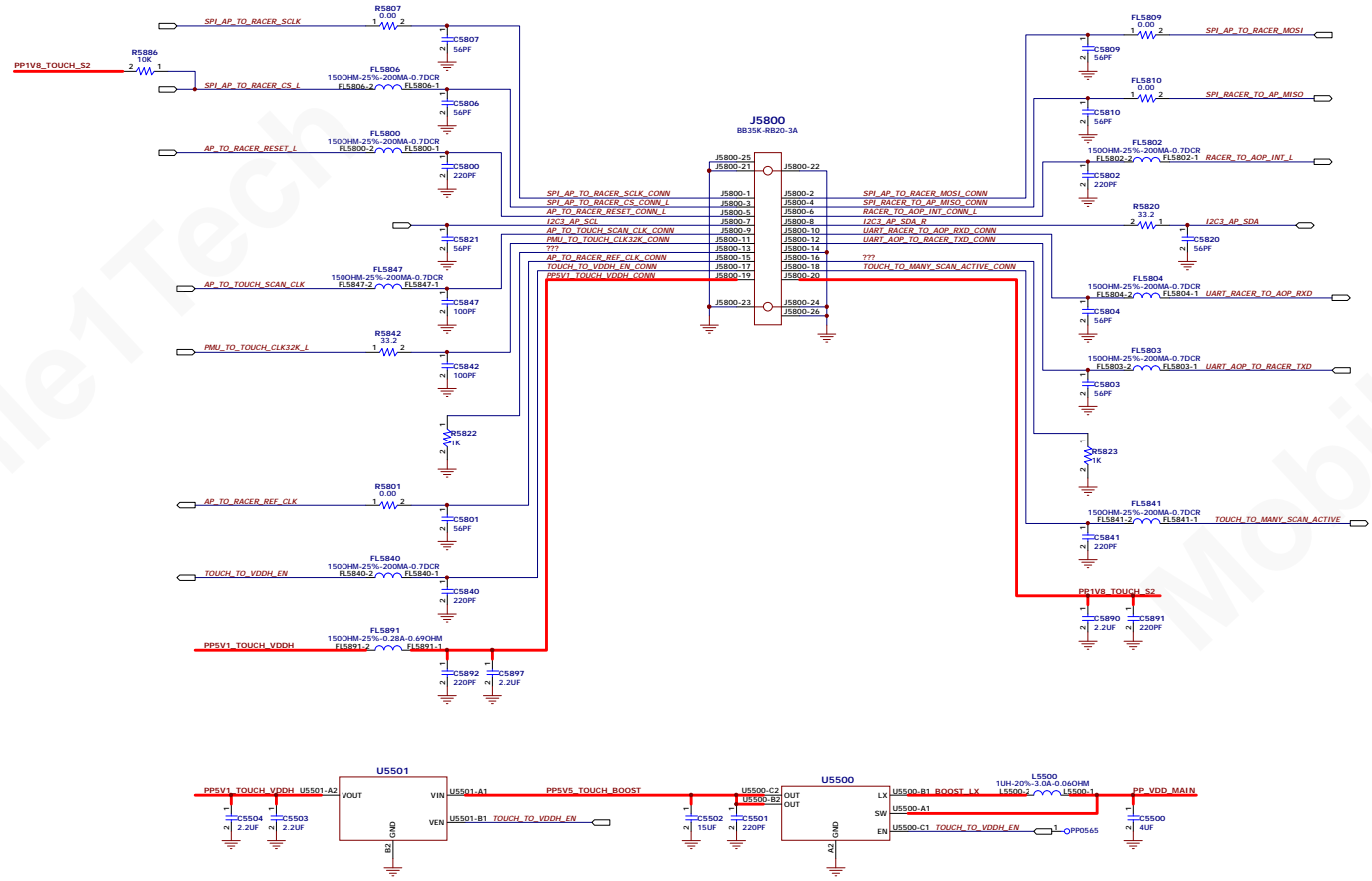

ARC & BOT SPK 震动器 & 扬声器

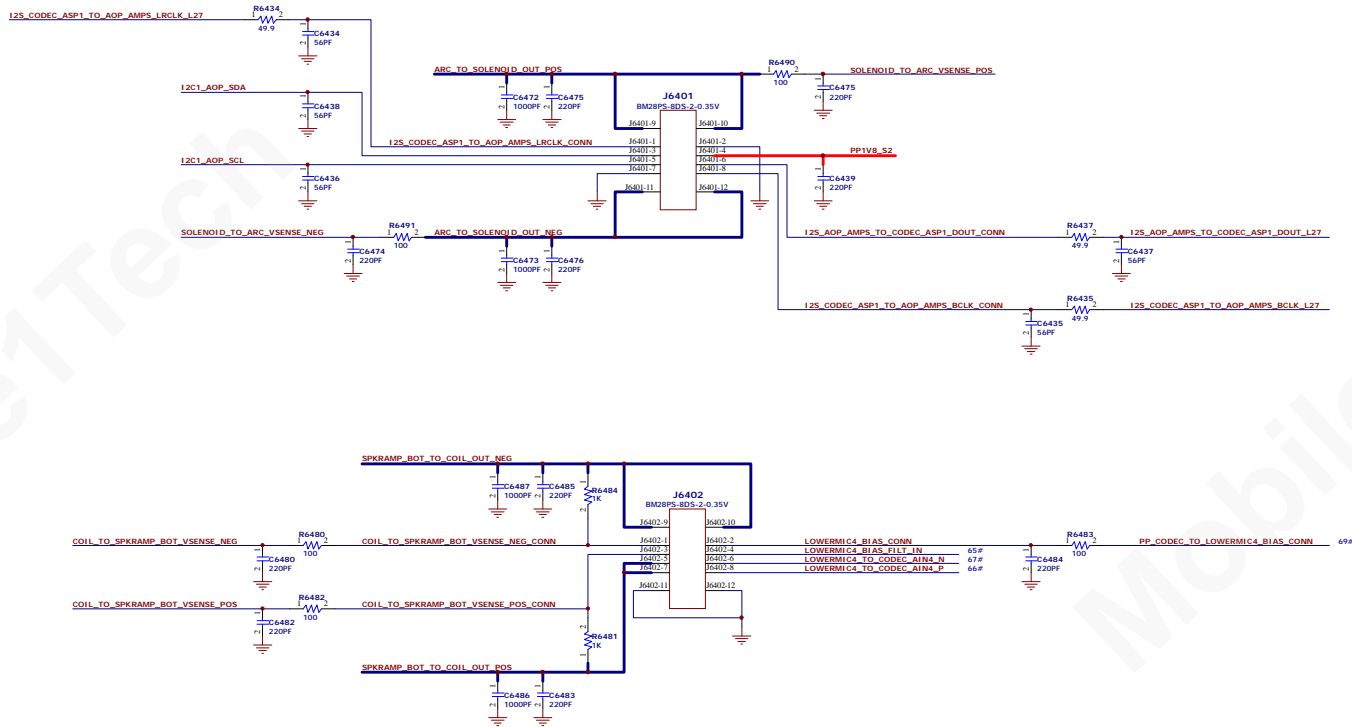

S4E NAND 硬盘

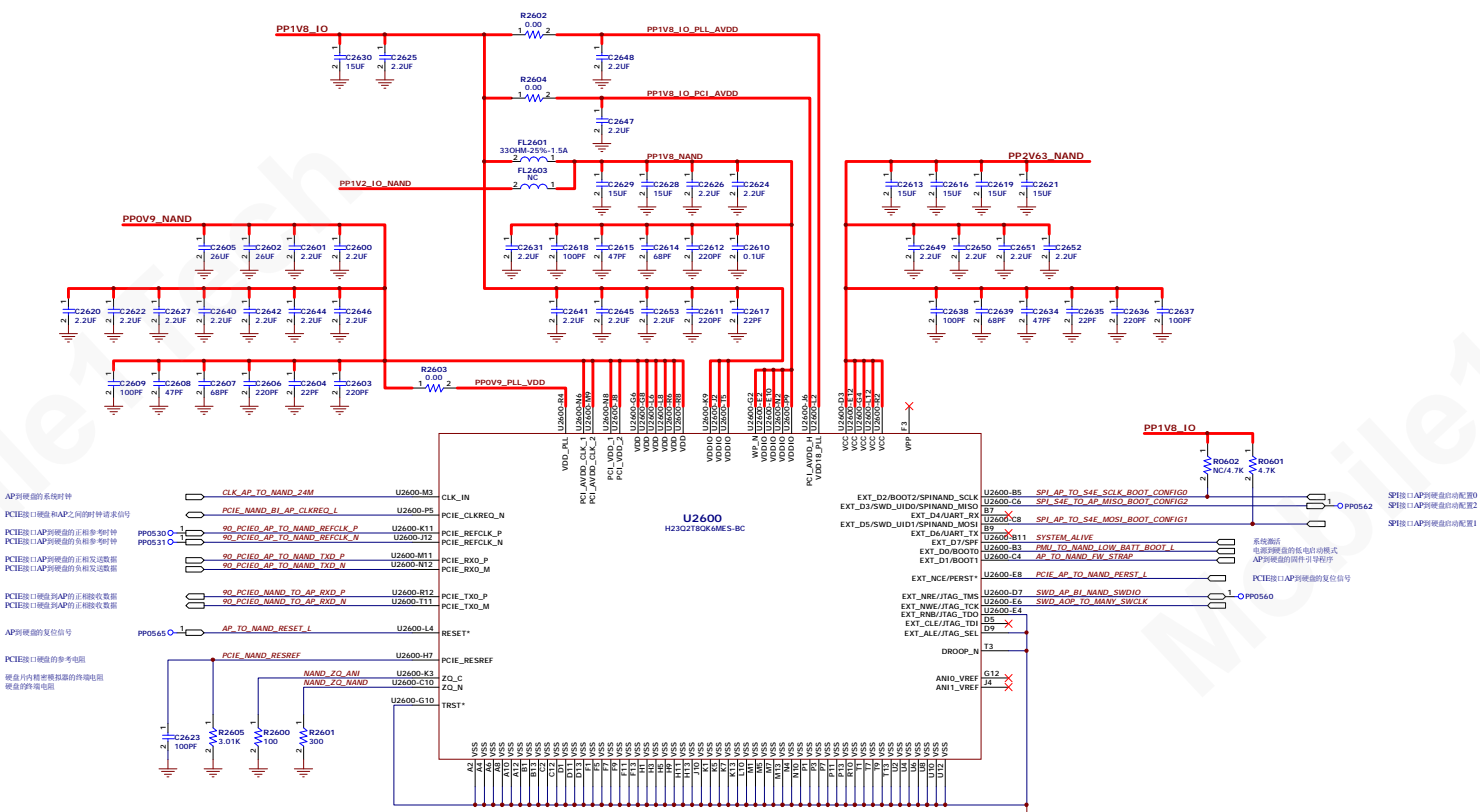

AP到硬盘的时钟信号	CLK_IN	U2600-M3	CLK_AP_TO_NAND_24M
PCIe接口硬盘和AP之间的时钟信号	PCIE_CLKREQ_N	U2600-P8	PCIE_NAND_BI_AP_CLKREQ_L
PCIe接口AP到硬盘的正相时钟信号	PCIE_REFCLK_P	U2600-K11	90_PCTEG_AP_TO_NAND_REFCLK_P
PCIe接口AP到硬盘的负相时钟信号	PCIE_REFCLK_N	U2600-T12	90_PCTEG_AP_TO_NAND_REFCLK_N
PCIe接口AP到硬盘的正相数据信号	PCIE_RX0_P	U2600-M11	90_PCTEG_AP_TO_NAND_TX0_P
PCIe接口AP到硬盘的负相数据信号	PCIE_RX0_M	U2600-N12	90_PCTEG_AP_TO_NAND_TX0_M
PCIe接口硬盘到AP的正相数据信号	PCIE_TX0_P	U2600-B12	90_PCTEG_NAND_TO_AP_RXD_P
PCIe接口硬盘到AP的负相数据信号	PCIE_TX0_M	U2600-T13	90_PCTEG_NAND_TO_AP_RXD_M
AP到硬盘的复位信号	RESET*	U2600-L4	AP_TO_NAND_RESET_L
PCIe接口硬盘的参考电压	PCIE_RESREF	U2600-H7	PCIE_NAND_RESREF
硬盘片内精密电阻的片端电压	Z0_C	U2600-K3	NAND_Z0_AW
硬盘的片端电压	Z0_N	U2600-C13	NAND_Z0_NAND
	TRST*	U2600-G10	

CALLAN AUDIO CODEC (ANALOG INPUTS & OUTPUTS)

语音编解码 1

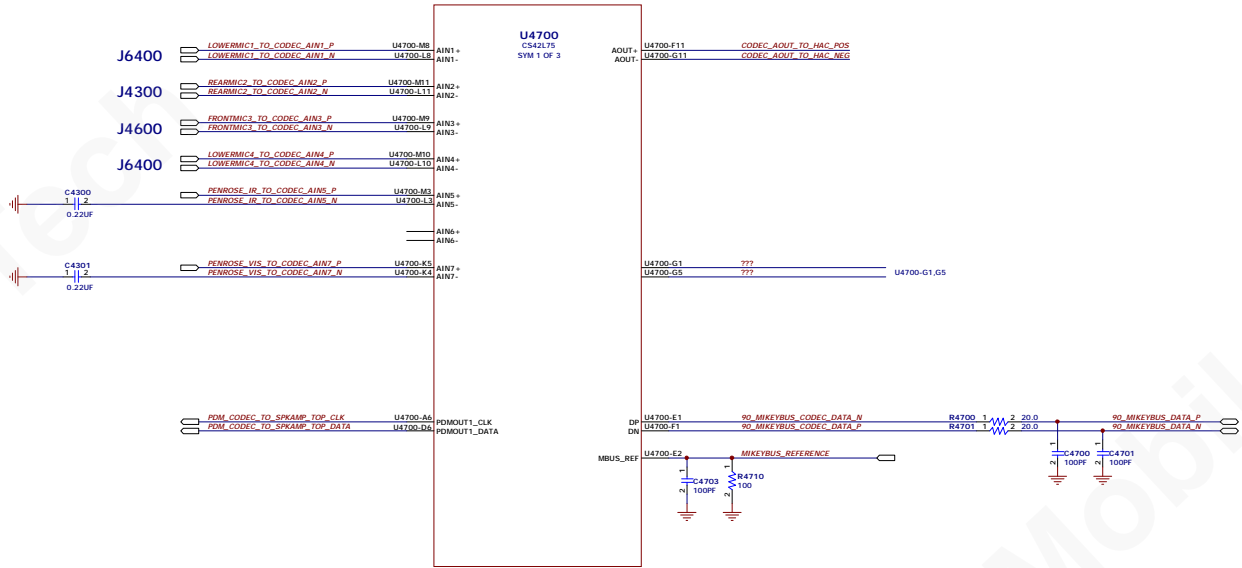

CALLAN AUDIO CODEC (POWER & I/O)

语音编解码 2

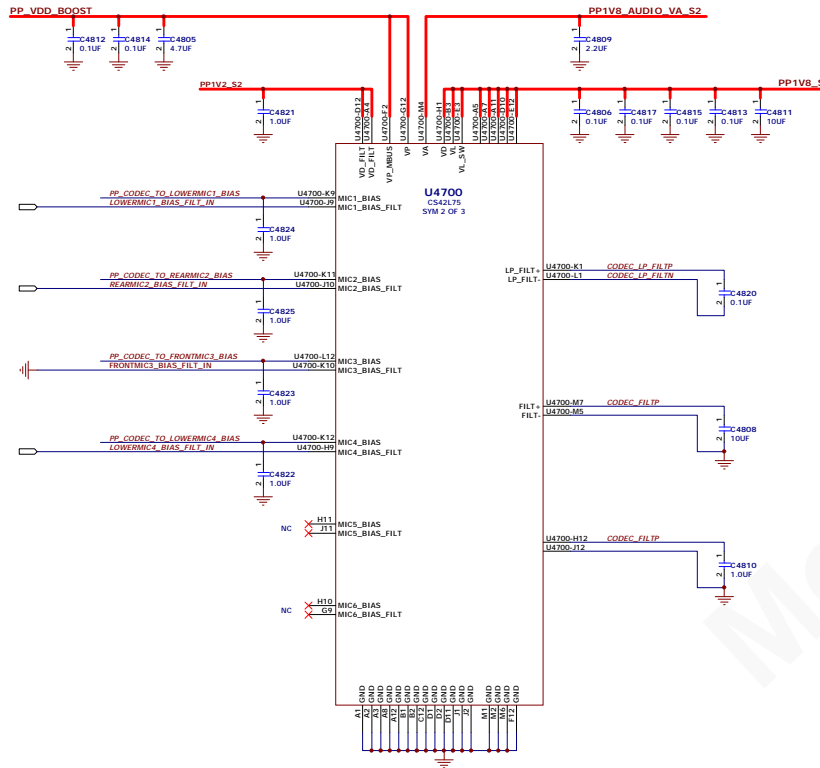

CALLAN AUDIO CODEC (POWER & I/O)

语音编解码 3

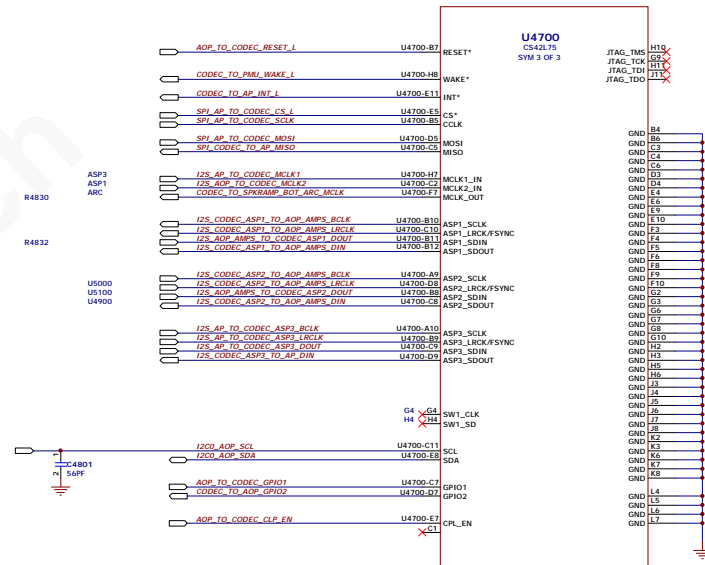

TOP SPKAMP 听筒音频放大器

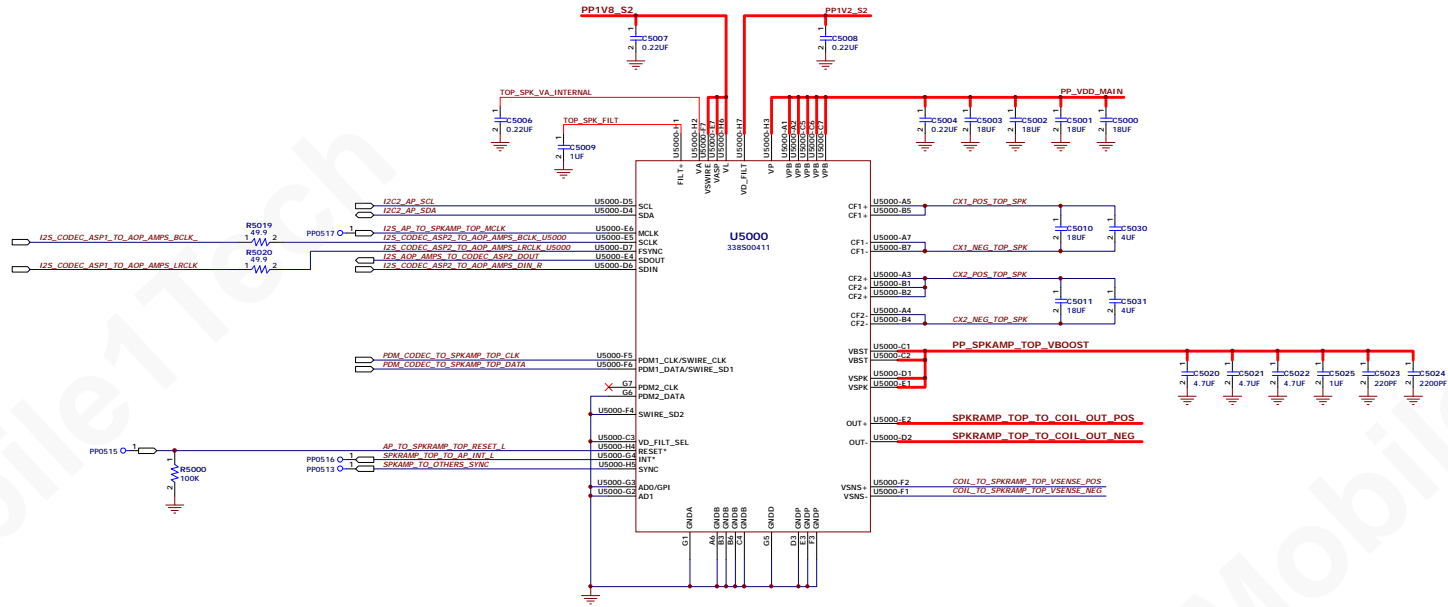

BOT SPKAMP

底部扬声器功放

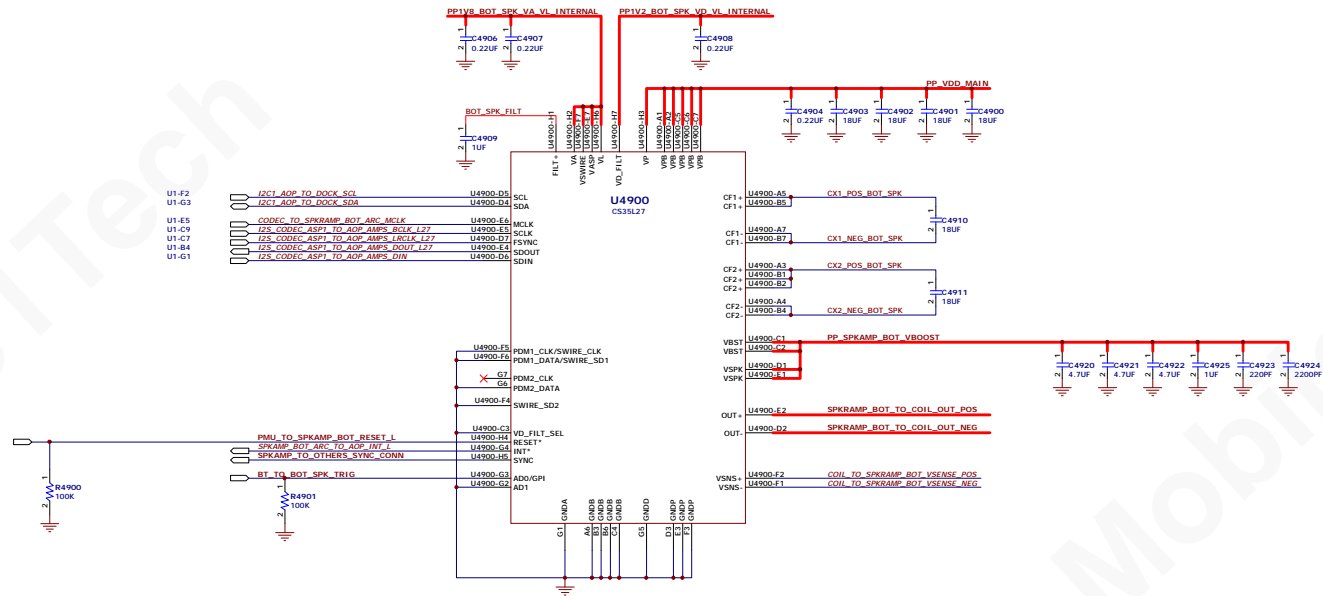

ARC: AMP 震动驱动器

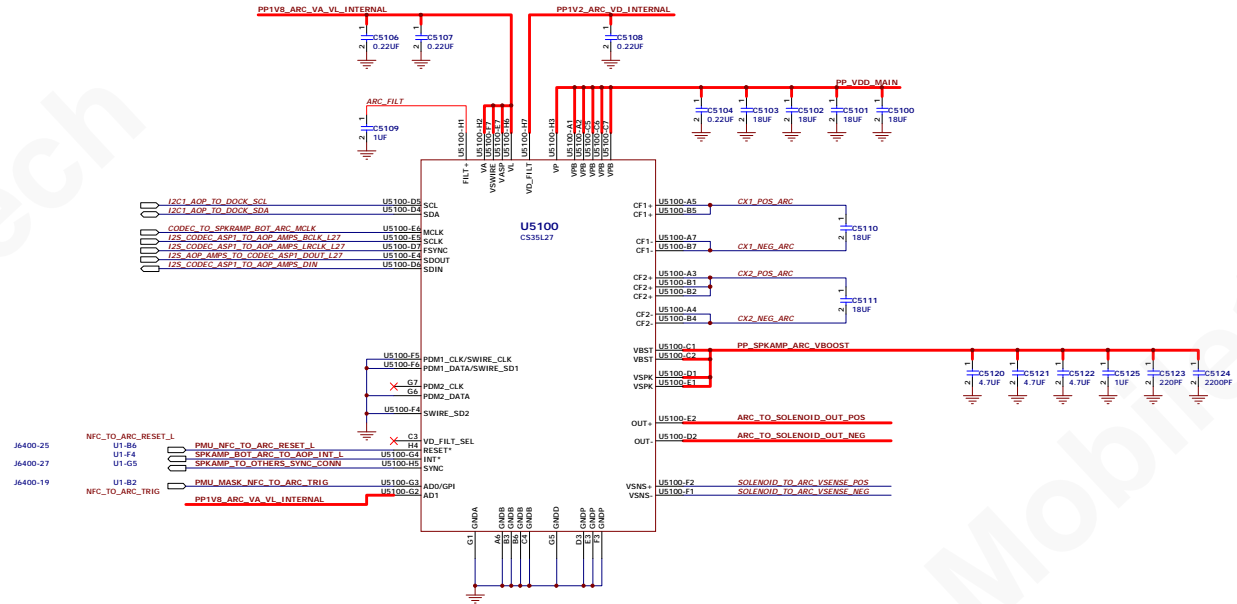

Rigel Driver 红外电源

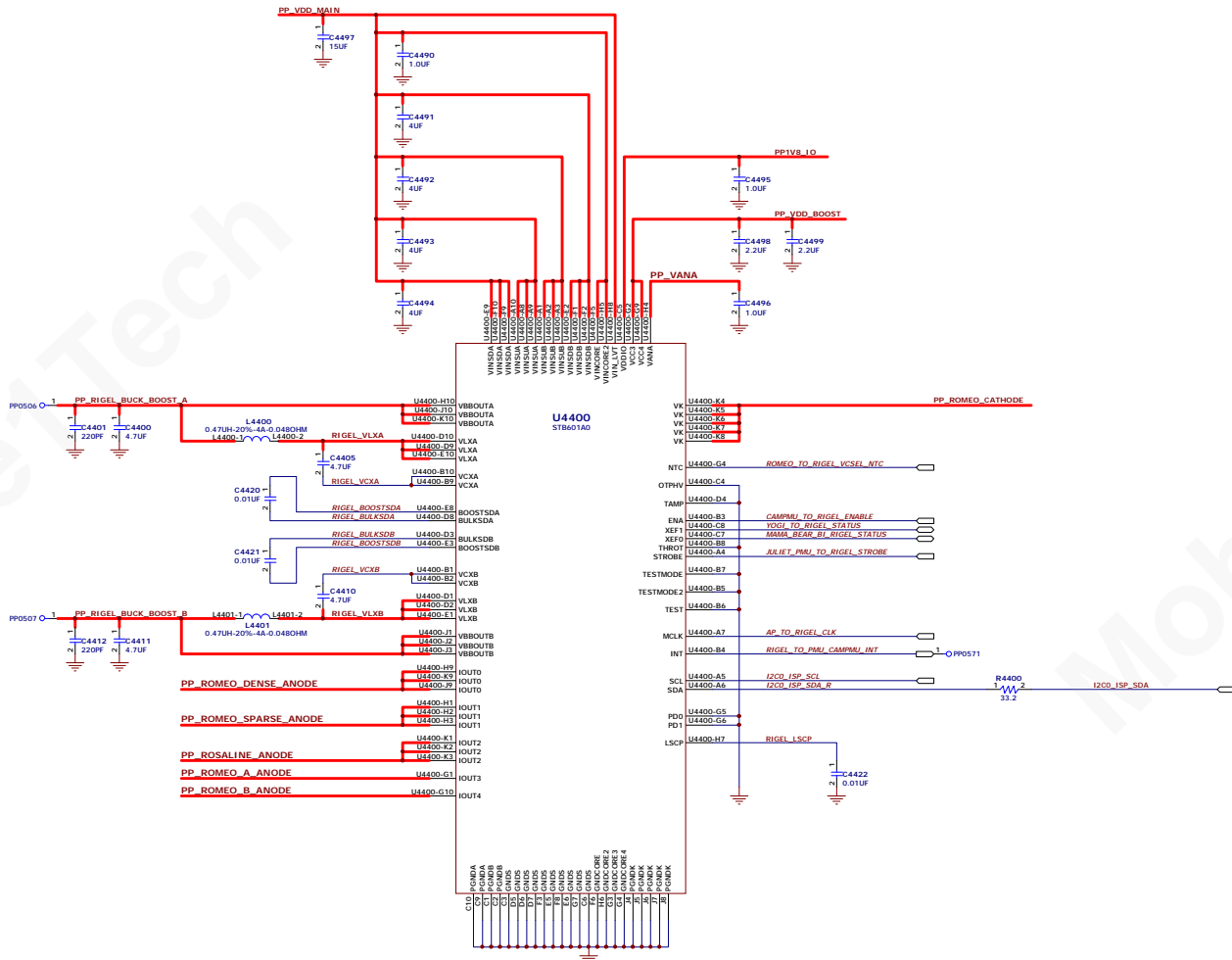

CAMERA: PMU

相机电源

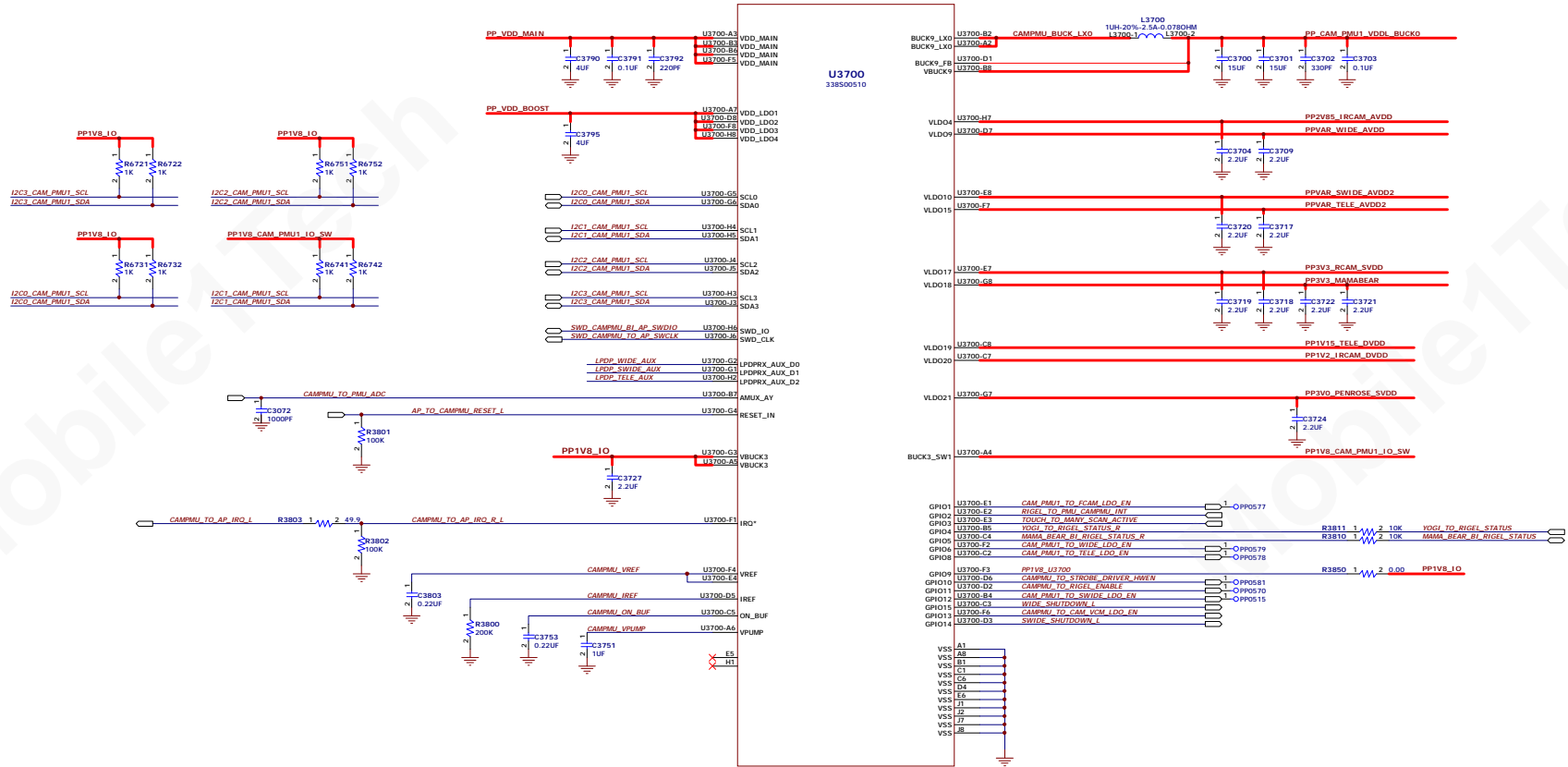

HALL

霍尔传感器 (开关)

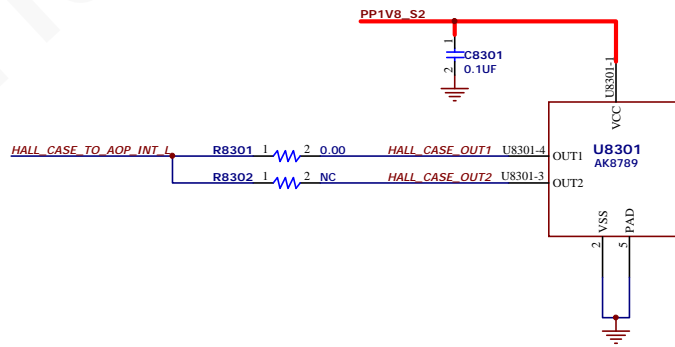

STOCKHOLM

近场通讯 (NFC)

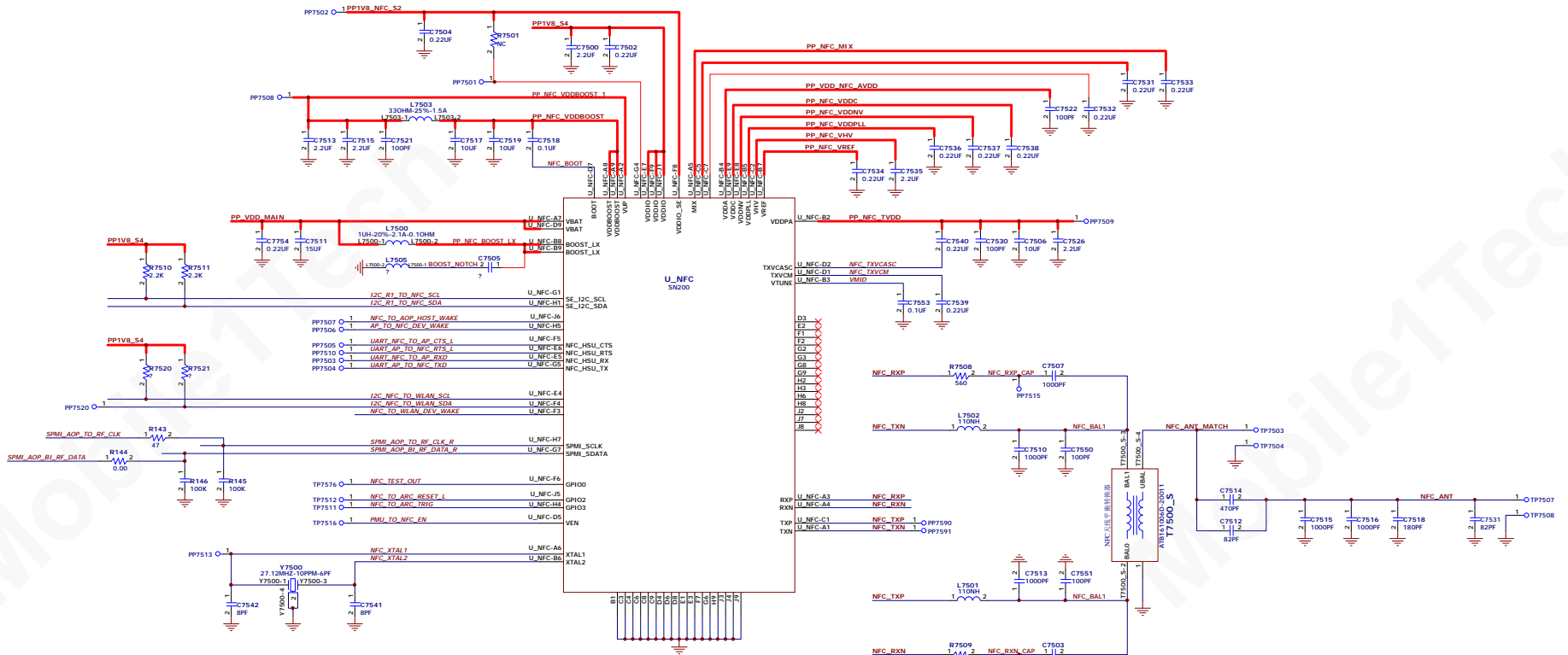

U_ROSE 微定位模组

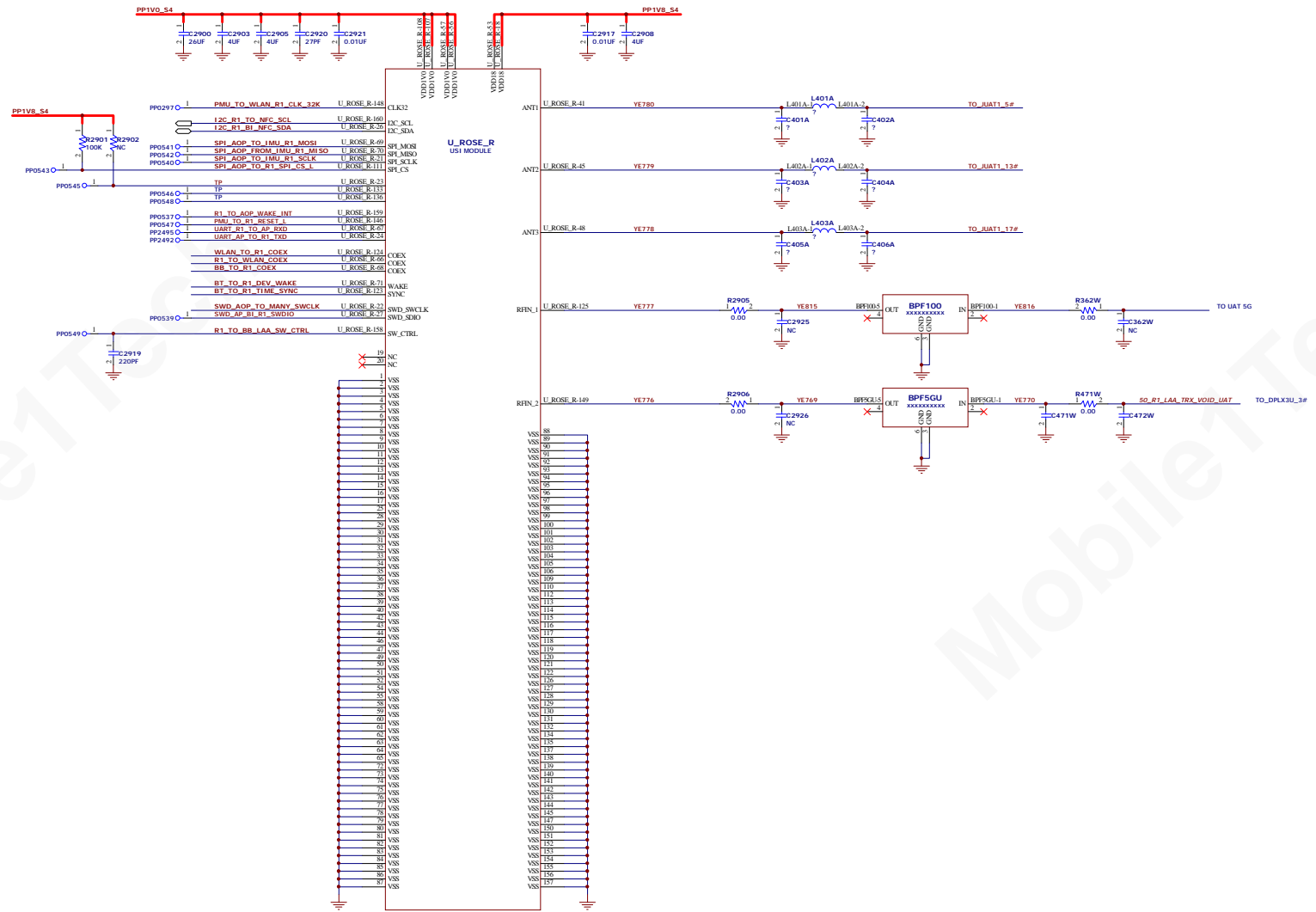

U3900//U3920//U3940 直流变换器

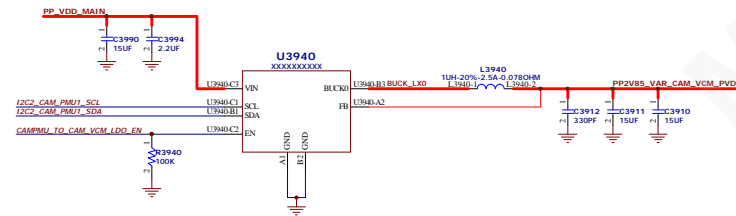
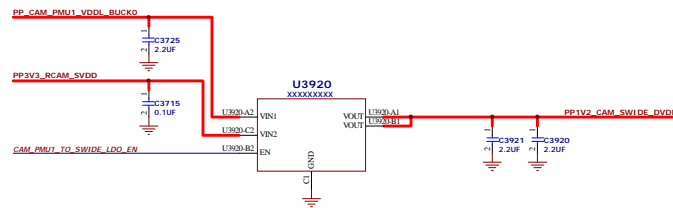
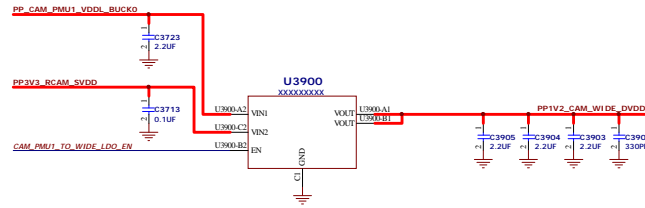

U4100/U4110/U4120/U4130/U4140 直流变换器

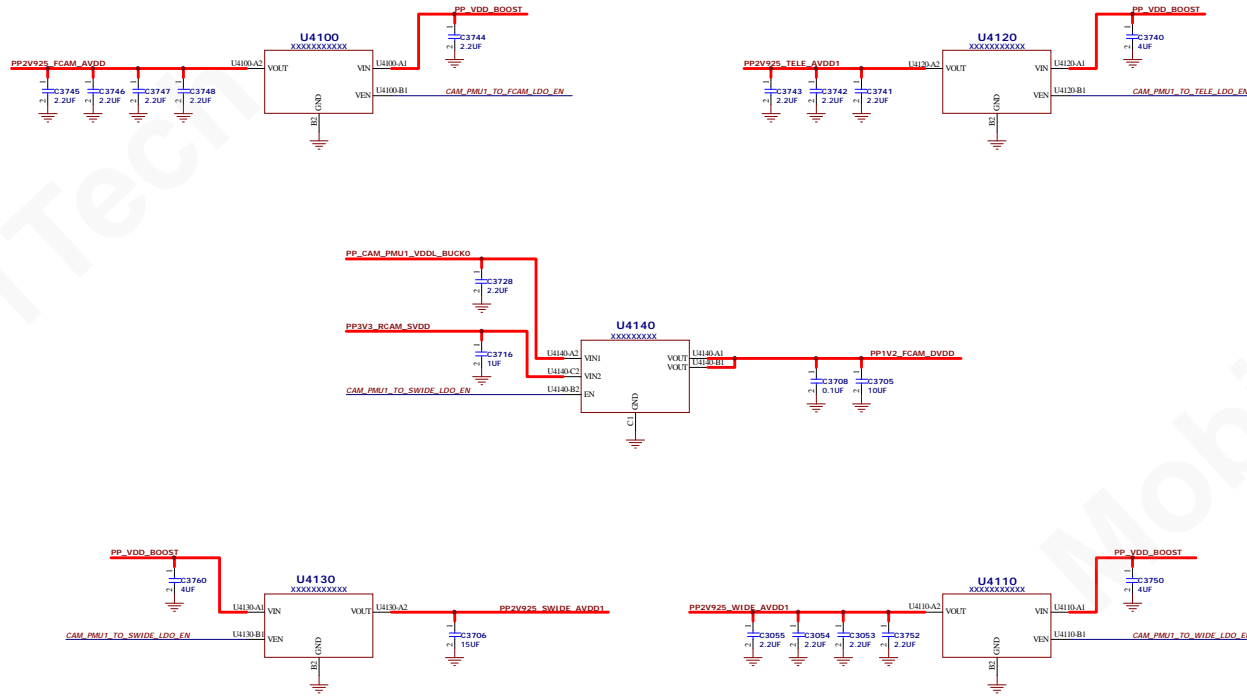

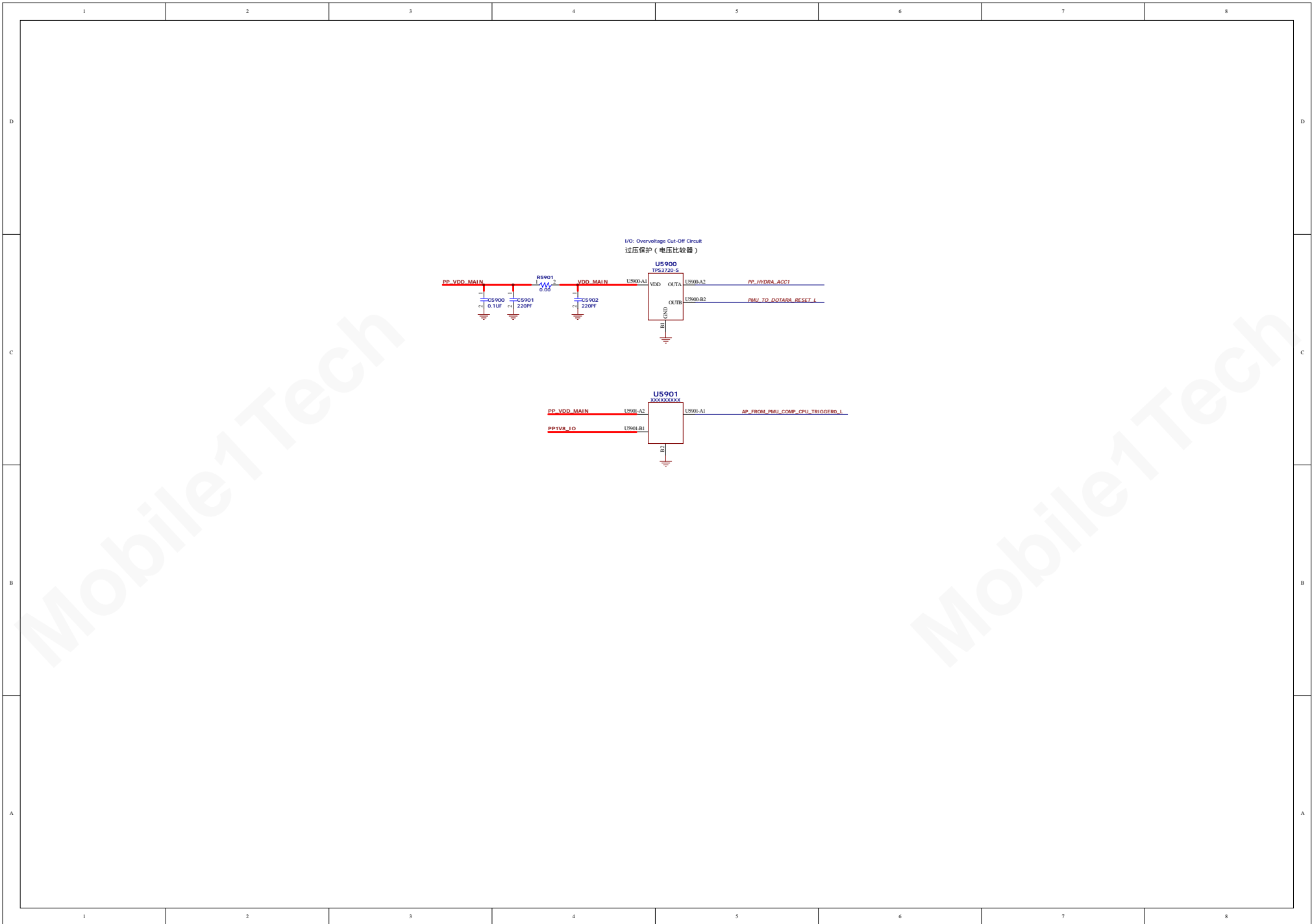

BOOST
SYSTEM POWER: Boost

主系统电源升压 3.4V to 3.4V

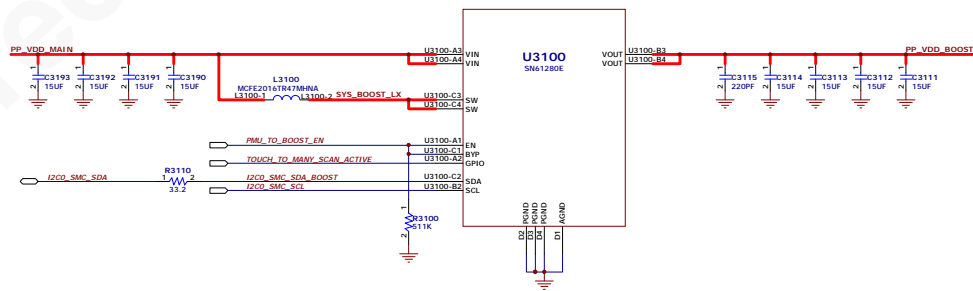

CHARGER 充电芯片

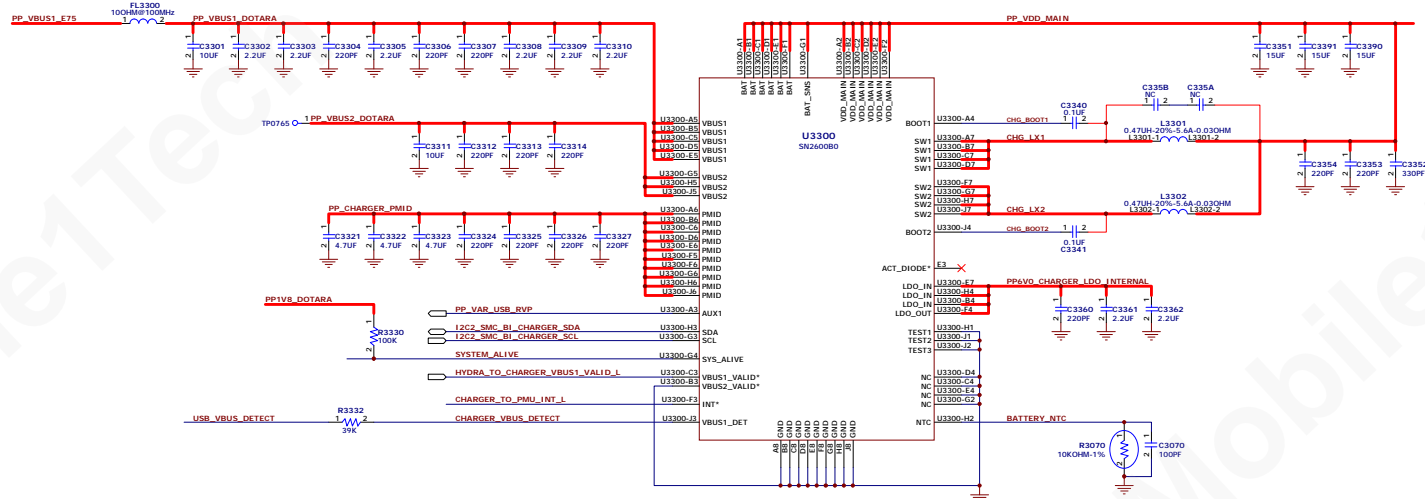

附件通道供电 Gecko

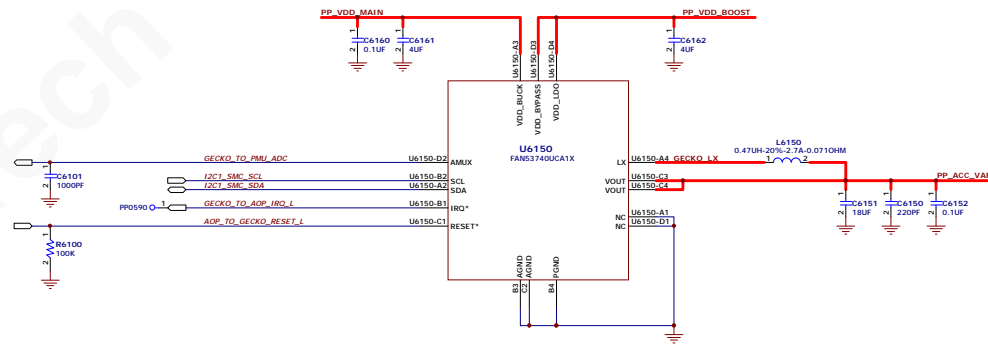

USB-PD PD快充控制器

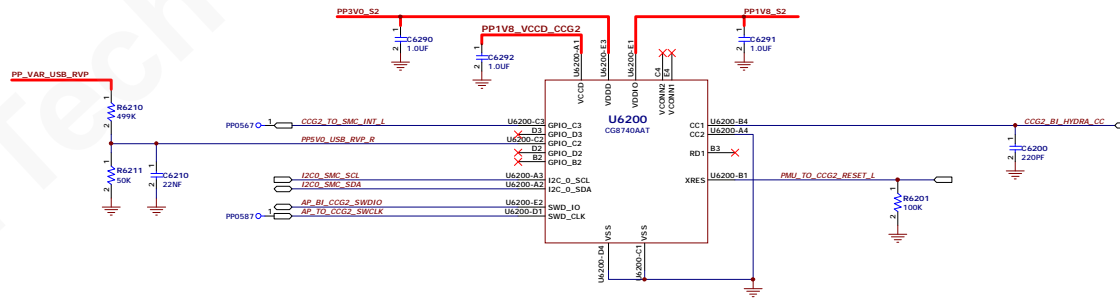

UPPER ANTENNA AND COUPLER

副天线耦合器

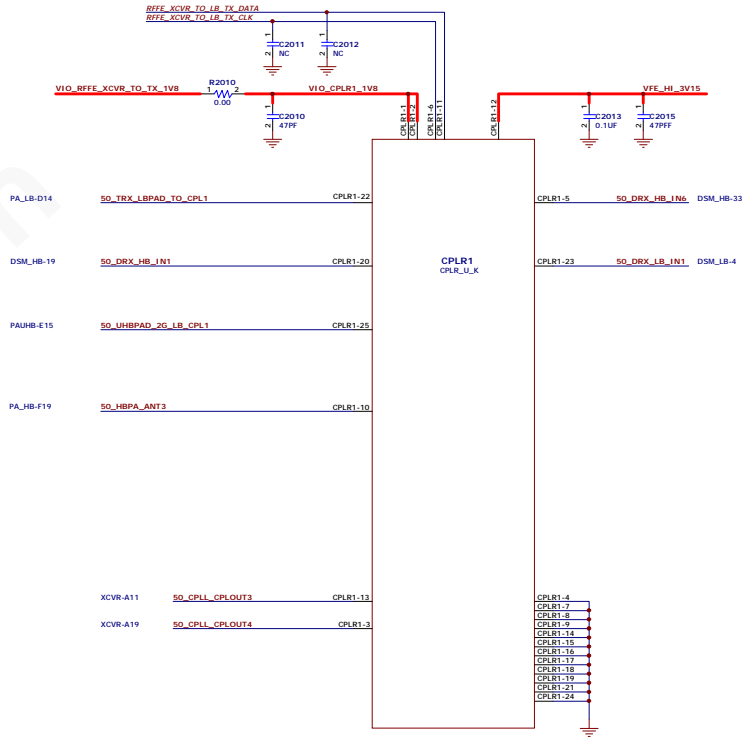

LOWER ANTENNA AND COUPLER

主天线耦合器

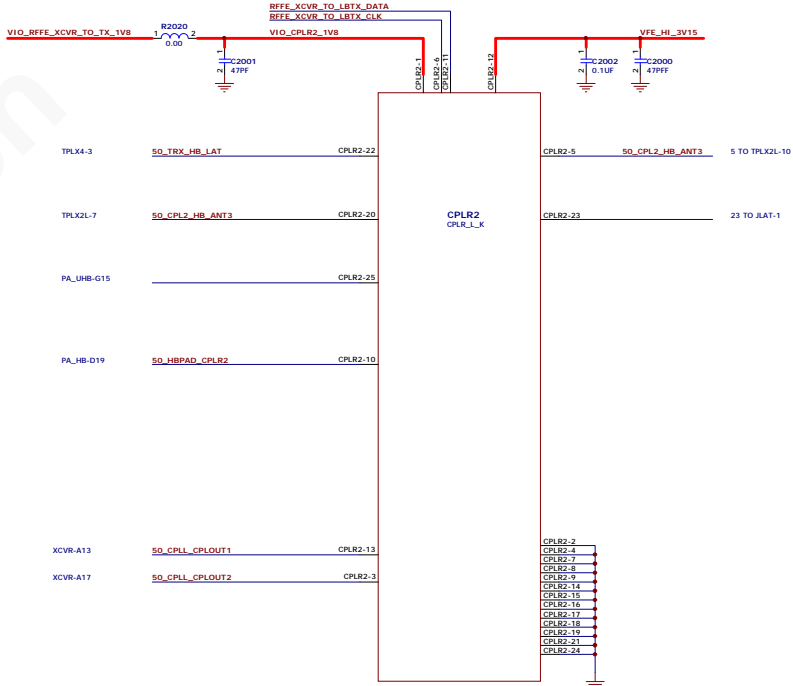

HB DIVERSITY RECEIVE LNA

高频多样性接收

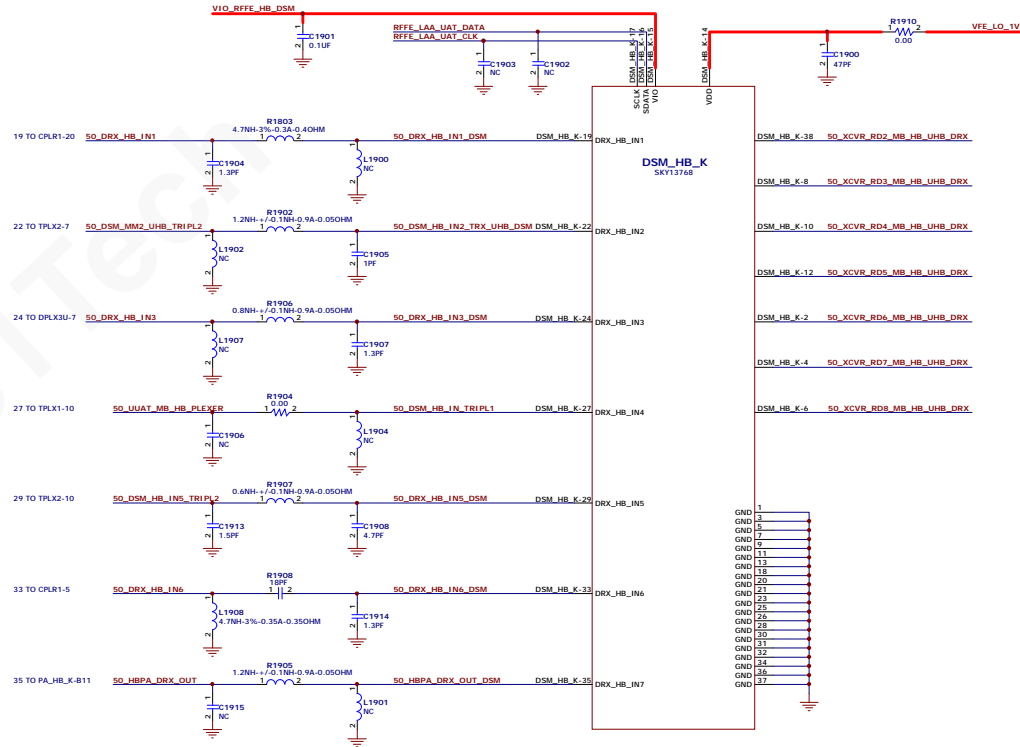

LB DIVERSITY RECEIVE LNA

低频多样性接收

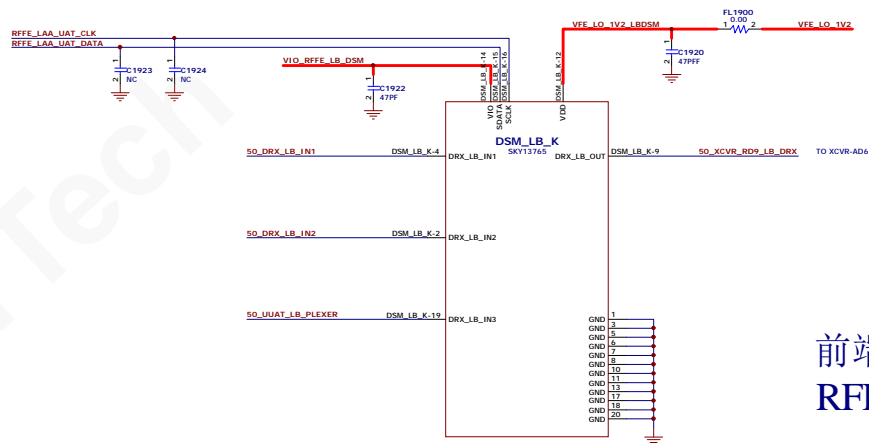

前端总线滤波电路

RFFE FILTERING

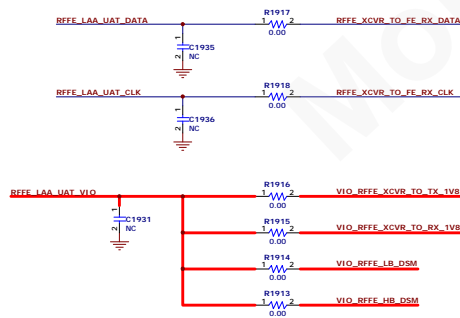

Charger Board Interposer

充电板内连器

J_INT_CHR		SMT-PAD		J_INT_CHR		SMT-PAD		U3-D2#		U3-C1#		U3-D4#		U3-D1#	
GND	1	IO1	46	???											
GND	2	IO2	47	GND											
BUTTON_VOL_UP_L_CONN	3	IO3	48	???											
GND	4	IO4	49	???											
BUTTON_RINGER_A_CONN	5	IO5	IO49	J INT CHR-50	PP_VBUS1_E75										
GND	6	IO6	IO50	J INT CHR-51	PP_VBUS1_E75										
I2C2_SMC_BI_CHARGER_SDA	J INT CHR-7	IO7	IO51	52	GND										
I2C1_AOP_SDA	J INT CHR-8	IO8	IO52	J INT CHR-53	PP_VBUS1_E75										
I2C2_SMC_BI_CHARGER_SCL	J INT CHR-9	IO9	IO53	J INT CHR-54	PMU_TO_DOTARA_EN_EXT_1V8										
GND	10	IO10	IO54	55	GND										
GND	11	IO11	IO55	J INT CHR-56	CLK_BBPMU_TO_DOTARA_38M4_1V8_CONN										
GND	12	IO12	IO56	J INT CHR-57	PP_VAR_USB_RVP										
I2C1_AOP_SCL	J INT CHR-13	IO13	IO57	J INT CHR-58	HYDRA_TO_CHARGER_VBUS1_VALID_L										
GND	14	IO14	IO58	59	GND										
I2S_CODEC_ASP1_TO_AOP_AMPS_LRCLK_L27	J INT CHR-15	IO15	IO59	60	GND										
GND	16	IO16	IO60	J INT CHR-61	TOUCH_TO_MANY_SCAN_ACTIVE										
GND	17	IO17	IO61	J INT CHR-62	CHARGER_CHECK										
GND	18	IO18	IO62	J INT CHR-63	CHARGER_TO_PMU_INT_L										
GND	19	IO19	IO63	J INT CHR-64	PMU_TO_DOTARA_RESET_L										
GND	20	IO20	IO64	J INT CHR-65	LOWERMIC4_BIAS_FILT_IN										
GND	21	IO21	IO65	J INT CHR-66	LOWERMIC4_TO_CODEC_AIN4_P										
GND	22	IO22	IO66	J INT CHR-67	LOWERMIC4_TO_CODEC_AIN4_N										
GND	23	IO23	IO67	J INT CHR-68	COIL_TO_SPKRAMP_BOT_VSENSE_POS										
GND	24	IO24	IO68	J INT CHR-69	PP_CODEC_TO_LOWERMIC4_BIAS_CONN										
GND	25	IO25	IO69	70	GND										
GND	26	IO26	IO70	71	GND										
PP_VDD_MAIN	J INT CHR-27	IO27	IO71	J INT CHR-72	SPKRAMP_BOT_TO_COIL_OUT_POS										
PP_VDD_MAIN	J INT CHR-28	IO28	IO72	J INT CHR-73	COIL_TO_SPKRAMP_BOT_VSENSE_NEG										
PP_VDD_MAIN	J INT CHR-29	IO29	IO73	J INT CHR-74	USB_VBUS_DETECT										
GND	30	IO30	IO74	J INT CHR-75	SPKRAMP_BOT_TO_COIL_OUT_NEG										
ARC_TO_SOLENOID_OUT_POS	J INT CHR-31	IO31	IO75	J INT CHR-76	BUTTON_VOL_DOWN_L_CONN										
PP_VBUS2_DOTARA	J INT CHR-32	IO32	IO76	J INT CHR-77	PP1V8_DOTARA										
ARC_TO_SOLENOID_OUT_NEG	J INT CHR-33	IO33	IO77	J INT CHR-78	PP1V8_S2										
SOLENOID_TO_ARC_VSENSE_POS	J INT CHR-34	IO34	IO78	79	GND										
GND	35	IO35	IO79	80	GND										
SOLENOID_TO_ARC_VSENSE_NEG	J INT CHR-36	IO36	IO80	81	GND										
SPMI_PMGR_TO_PMU_SCLK_CONN	J INT CHR-37	IO37	IO81	82	GND										
SPMI_PMU_BI_PMGR_SDATA_CONN	J INT CHR-38	IO38	IO82	83	GND										
???	J INT CHR-39	IO39	IO83	84	GND										
GND	40	IO40	IO84	85	GND										
I2S_AOP_AMPS_TO_CODEC_ASP1_DOUT_L27	J INT CHR-41	IO41	IO85	86	X										
GND	42	IO42	IO86	87	X										
I2S_CODEC_ASP1_TO_AOP_AMPS_BCLK_L27	J INT CHR-43	IO43	IO87												
RT2	J INT CHR-44	IO44													
RT1	J INT CHR-45	IO45													

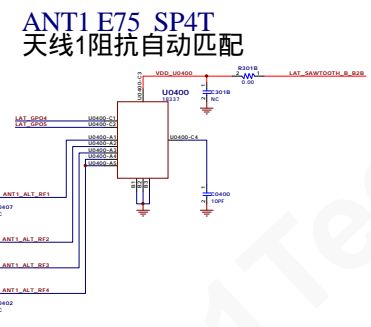
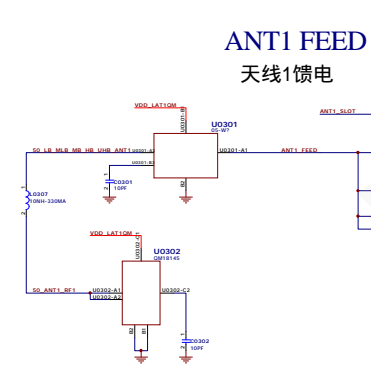
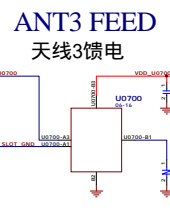
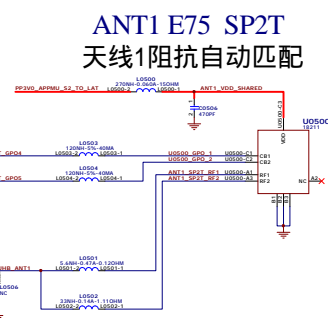
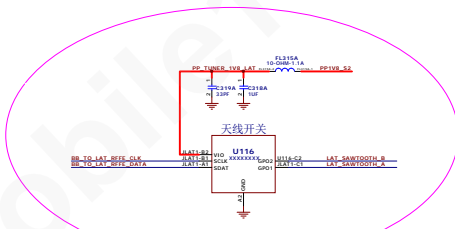
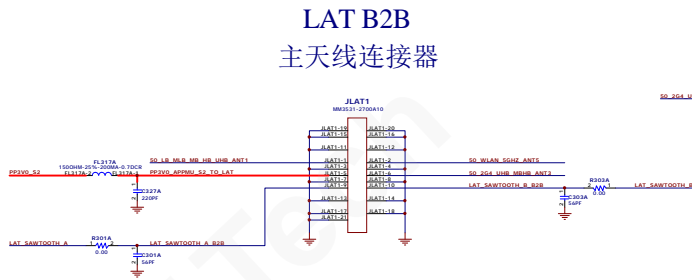

UAT B2BS 副天线连接器

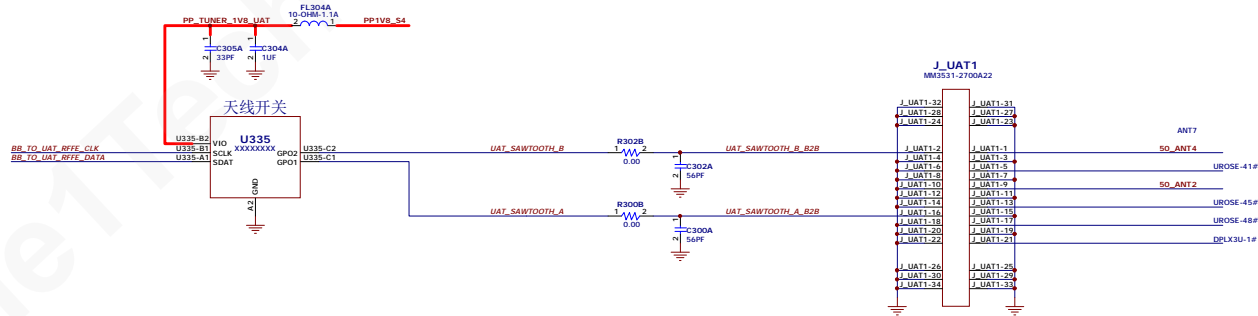

DEBUG CONNECTOR 调试连接器

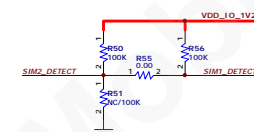
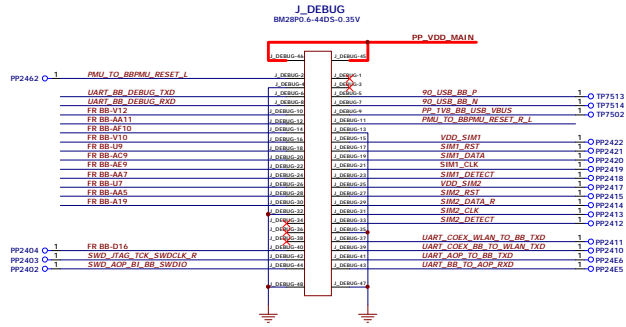

LAT ANTENNA FEEDS

LOWER ANTENNA & COUPLER

主天线馈电

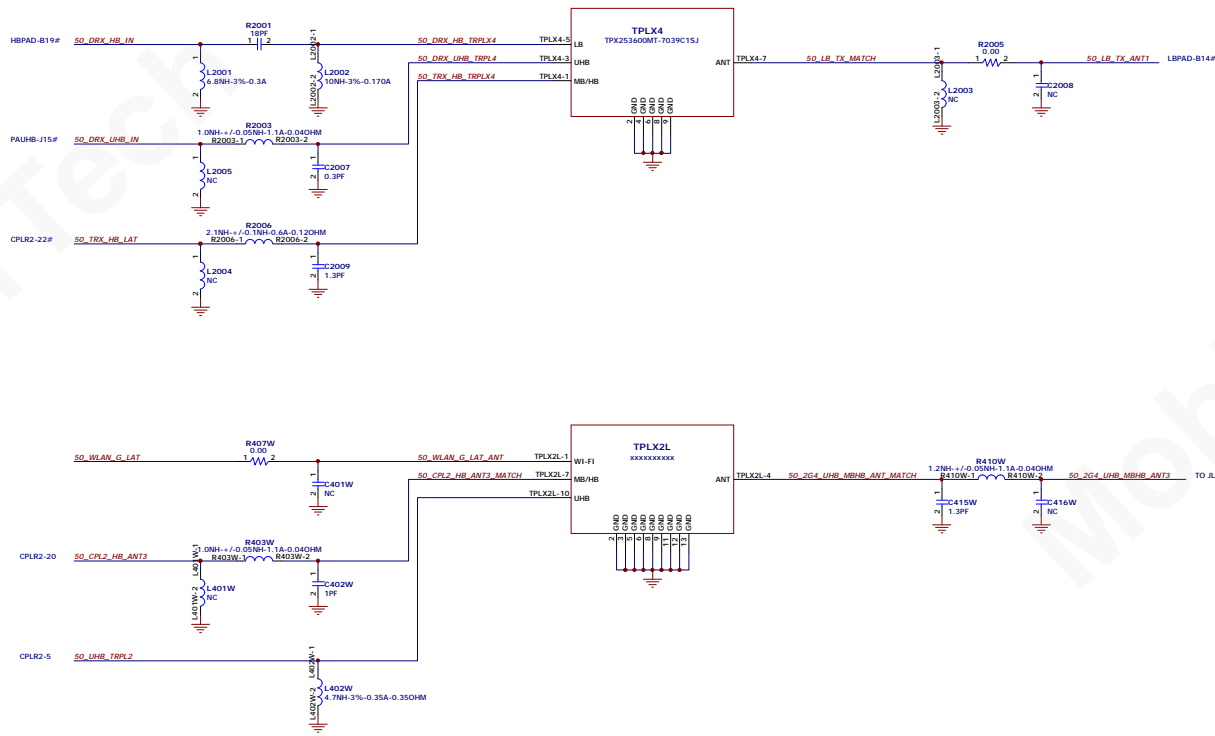

LOWERMIC1 底部麦克风

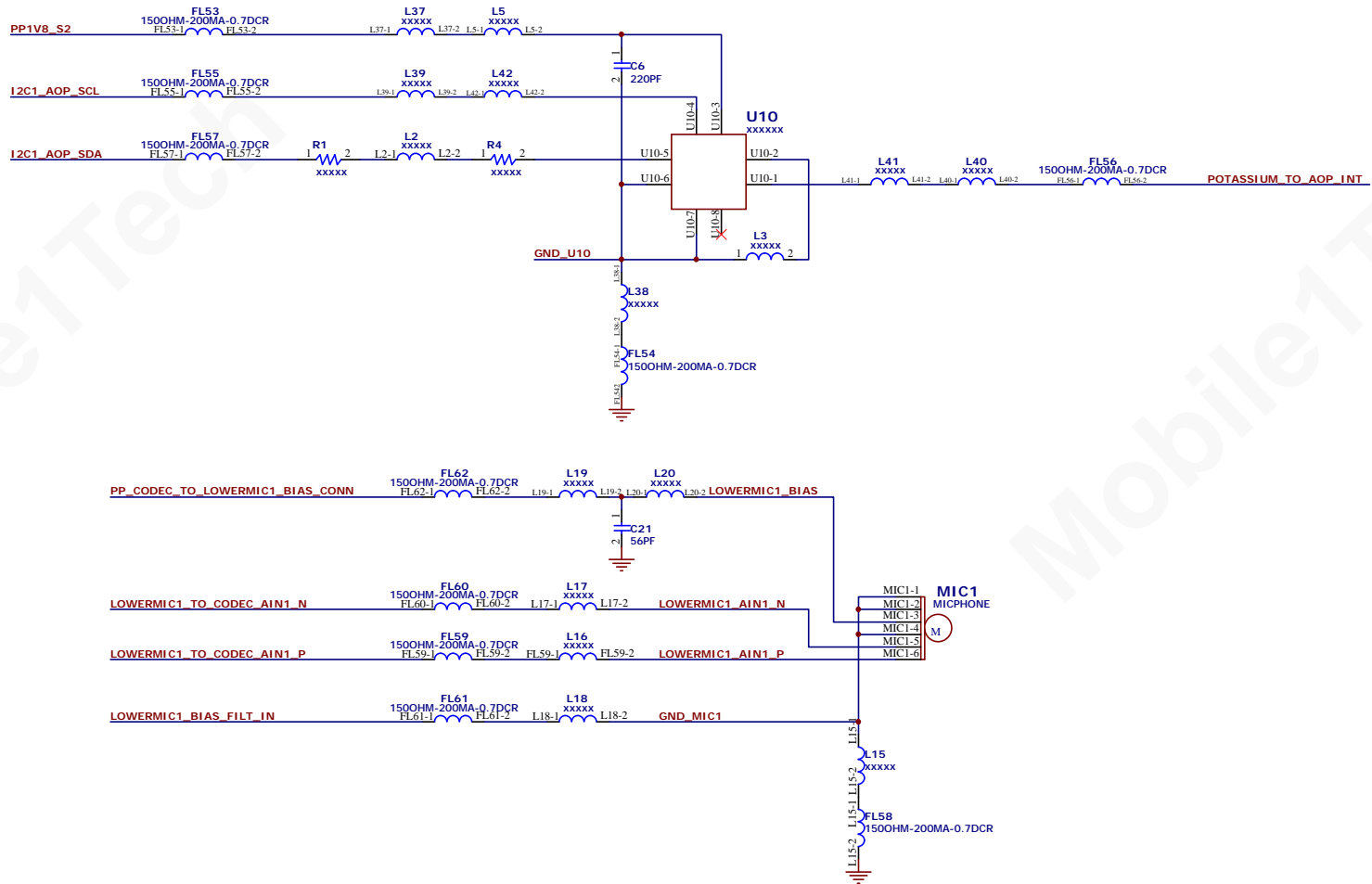

低频段射频功放 LB SPAD

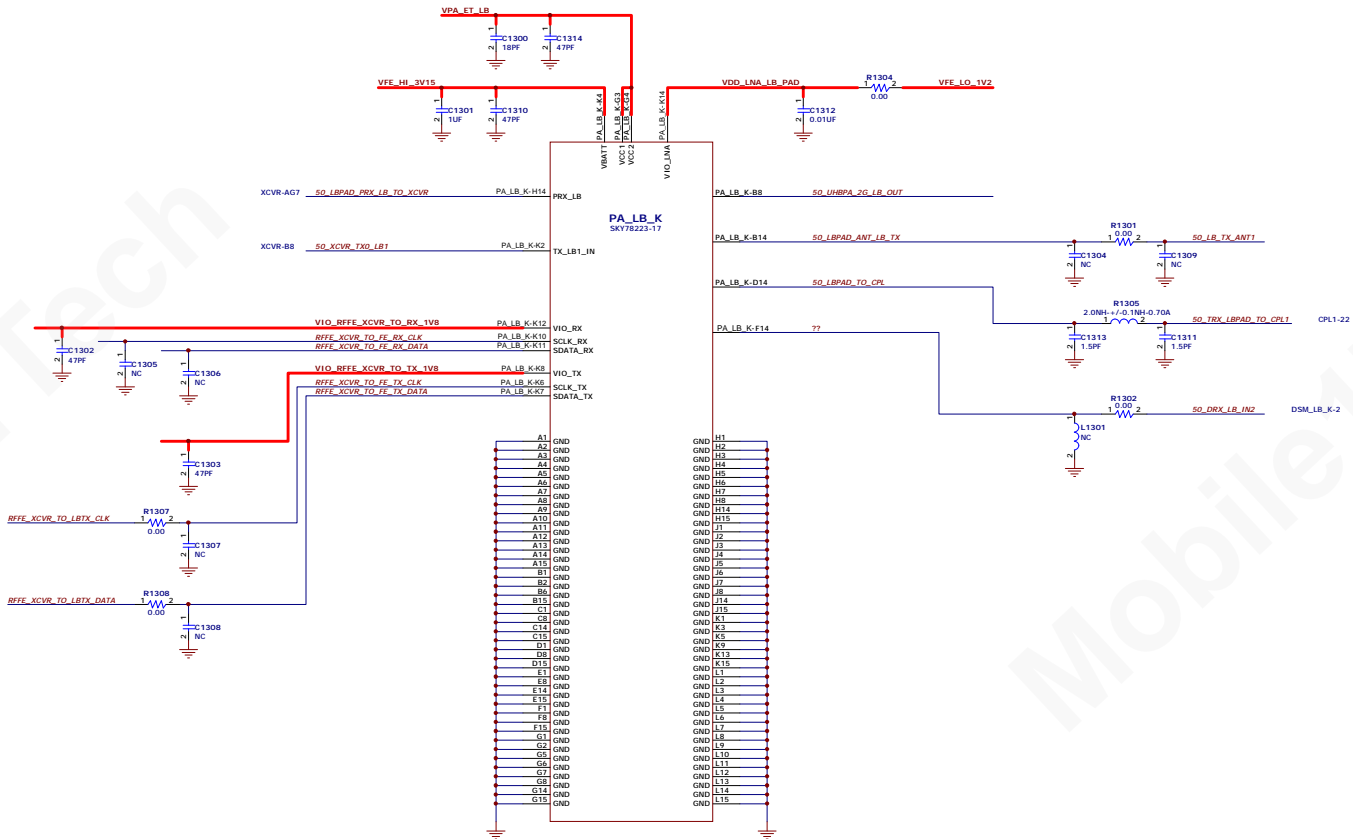

UHB LMB SPAD

超高频段功率放大器

